

ASSEMBLY INSTRUCTIONS
COASTER FINE FURNITURE

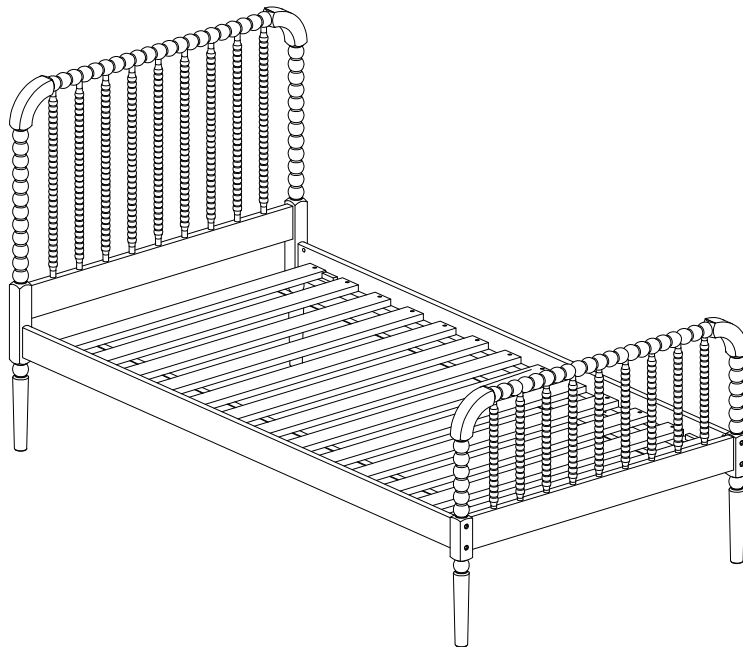

Fine Furniture for every stage of life

400415T (B1-B2)
Twin Bed

ITEM: 400415T(B1-B2)

ASSEMBLY INSTRUCTIONS



ASSEMBLY TIPS:

1. Remove hardware from box and sort by size.
2. Please check to see that all hardware and parts are present prior to start of assembly.
3. Please follow attached instructions in the same sequence as numbered to assure fast & easy assembly .

WARNING!



1. Don't attempt to repair or modify parts that are broken or defective. Please contact the store immediately.
2. This product is for home use only and not intended for commercial establishments.

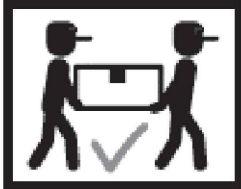

ASSEMBLY TIME

20 MINUTES

PARTS IDENTIFICATION

B1 (BOX 1)

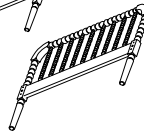
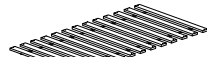



A	HEADBOARD		1PC
B	FOOTBOARD		1PC
C	ROLL SLAT (13PCS)		1SET

B2 (BOX 2)

D	BED RAILS		2PCS
---	-----------	---	------

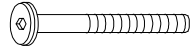
HARDWARE IDENTIFICATION

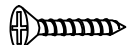
Z-B2 (BOX 2) HARDWARE PACK IS LOCATED IN 400415T (B2)

1	BOLT (M6 x 80 x 13mm - WH)		8PCS
2	BARREL NUT (M6 x 13mm - WH)		8PCS
3	WOOD DOWEL (10 x 40mm)		4PCS
4	SCREW (4 x 30mm - WH)		6PCS
5	ALLEN WRENCH (4 x 65mm - WH)		1PC

NOTE :

Phillips head screw driver is required in the assembly process; however, manufacturer does not provide this item.

ITEM: **400415T(B1-B2)**

ASSEMBLY INSTRUCTIONS



STEP 1

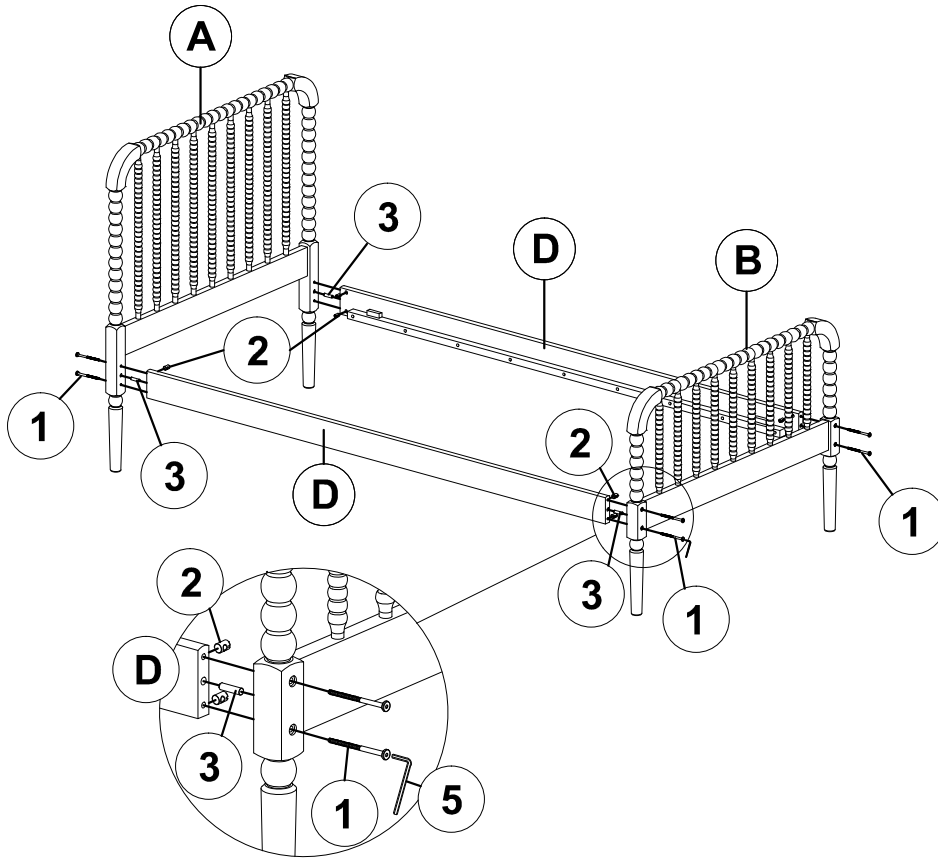

STEP 2

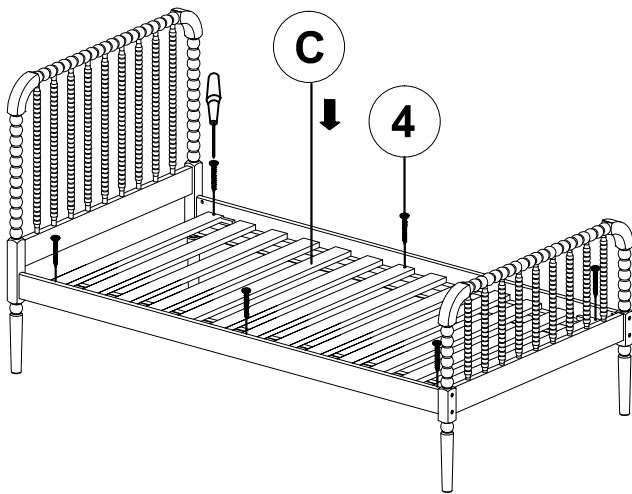

STEP 3
COMPLETE

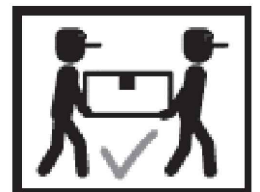
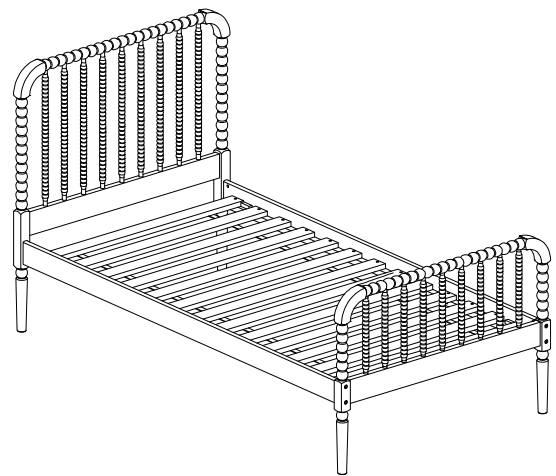

ITEM: **400415T(B1-B2)**



INNER SIZE : 75.59" X 39.09"

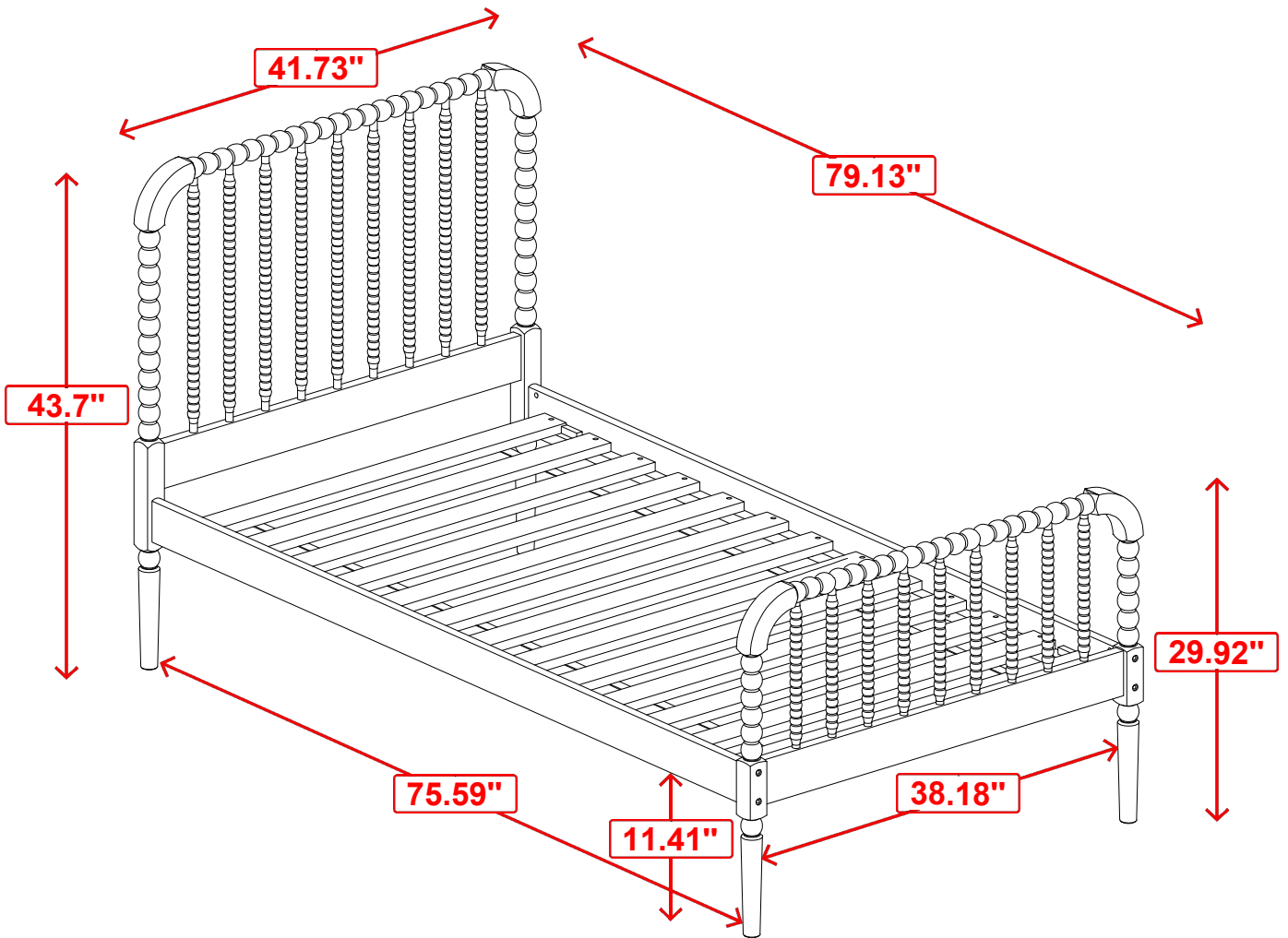

Note: Dimension tolerance $\pm 5\%$