

ASSEMBLY INSTRUCTIONS
COASTER FINE FURNITURE



Fine Furniture for every stage of life

802999
WRITING DESK

ITEM: **802999**



ASSEMBLY INSTRUCTIONS

ASSEMBLY TIPS:

1. Remove hardware from box and sort by size.
2. Please check to see that all hardware and parts are present prior to start of assembly.
3. Please follow attached instructions in the same sequence as numbered to assure fast & easy assembly.



WARNING!

1. Don't attempt to repair or modify parts that are broken or defective. Please contact the store immediately.
2. This product is for home use only and not intended for commercial establishments.



ASSEMBLY TIME

60 MINUTES





PARTS IDENTIFICATION

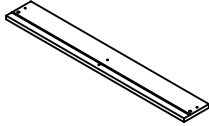

AN	LEFT SIDE PANEL		1 PC	JN	LEFT DRAWER FRONT PANEL		2 PCS
BN	RIGHT SIDE PANEL		1 PC	KN	SMALL DRAWER BACK PANEL		2 PCS
CN	LEFT DIVIDER PANEL		1 PC	LN	SMALL LEFT DRAWER SIDE PANEL		2 PCS
DN	RIGHT DIVIDER PANEL		1 PC	MN	SMALL RIGHT DRAWER SIDE PANEL		2 PCS
EN	LEFT BOTTOM PANEL		1 PC	NN	DRAWER BOTTOM PANEL		3 PCS
FN	RIGHT BOTTOM PANEL		1 PC	ON	RIGHT DRAWER FRONT PANEL		1 PC
GN	BACK BOTTOM PANEL		1 PC	PN	LARGE DRAWER BACK PANEL		1 PC
HN	BACK PANEL		1 PC	QN	LARGE LEFT DRAWER SIDE PANEL		1 PC
IN	TOP PANEL		1 PC	RN	LARGE RIGHT DRAWER SIDE PANEL		1 PC

NOTE:

Phillips head screw driver is required in the assembly process; however, manufacturer does not provide this item.



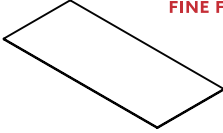

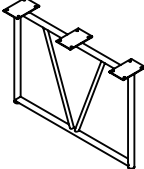





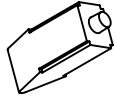

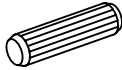
ITEM: 802999

SN	MIDDLE DRAWER FRONT PANEL		1 PC
TN	MIDDLE DRAWER BACK PANEL		1 PC
UN	MIDDLE LEFT DRAWER SIDE PANEL		1 PC
VN	MIDDLE RIGHT DRAWER SIDE PANEL		1 PC

A1N	MIDDLE DRAWER BOTTOM PANEL		1 PC
B1N	DRAWER SUPPORT		1 PC
C1N	METAL FRAME		2 PCS

Z

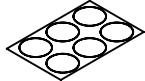
HARDWARE IDENTIFICATION

NO	DESCRIPTION	FIGURE	Q'TY	NO	DESCRIPTION	FIGURE	Q'TY
1	GLUE 40g		1 PC	8	SCREW FOR RAIL Ø 3.5x12mm SR		40 PCS
2	WOODEN DOWEL Ø 8x30mm		38 PCS	9	KNOB		4 PCS
3	CAM BOLT Ø 7x35.5mm SR		20 PCS	10	KNOB BOLT Ø 4x28mm BLK		4 PCS
4	CAM LOCK Ø 15x12mm SR		20 PCS	11	BOLT M 6x20mm BLK		24 PCS
5	LONG SCREW Ø 4.5x42mm SR		19 PCS	12	ALLEN WRENCH 4mm SR		1 PC
6	SCREW Ø 4.3x35mm SR		17 PCS	13	STICKER Ø 20mm		4 PCS
7	RAIL L = 350mm SR		4 SET				

Z7 not included in blister packaging.

NOTE:

Phillips head screw driver is required in the assembly process; however, manufacturer does not provide this item.

ITEM: 802999



FINE FURNITURE

STEP 1

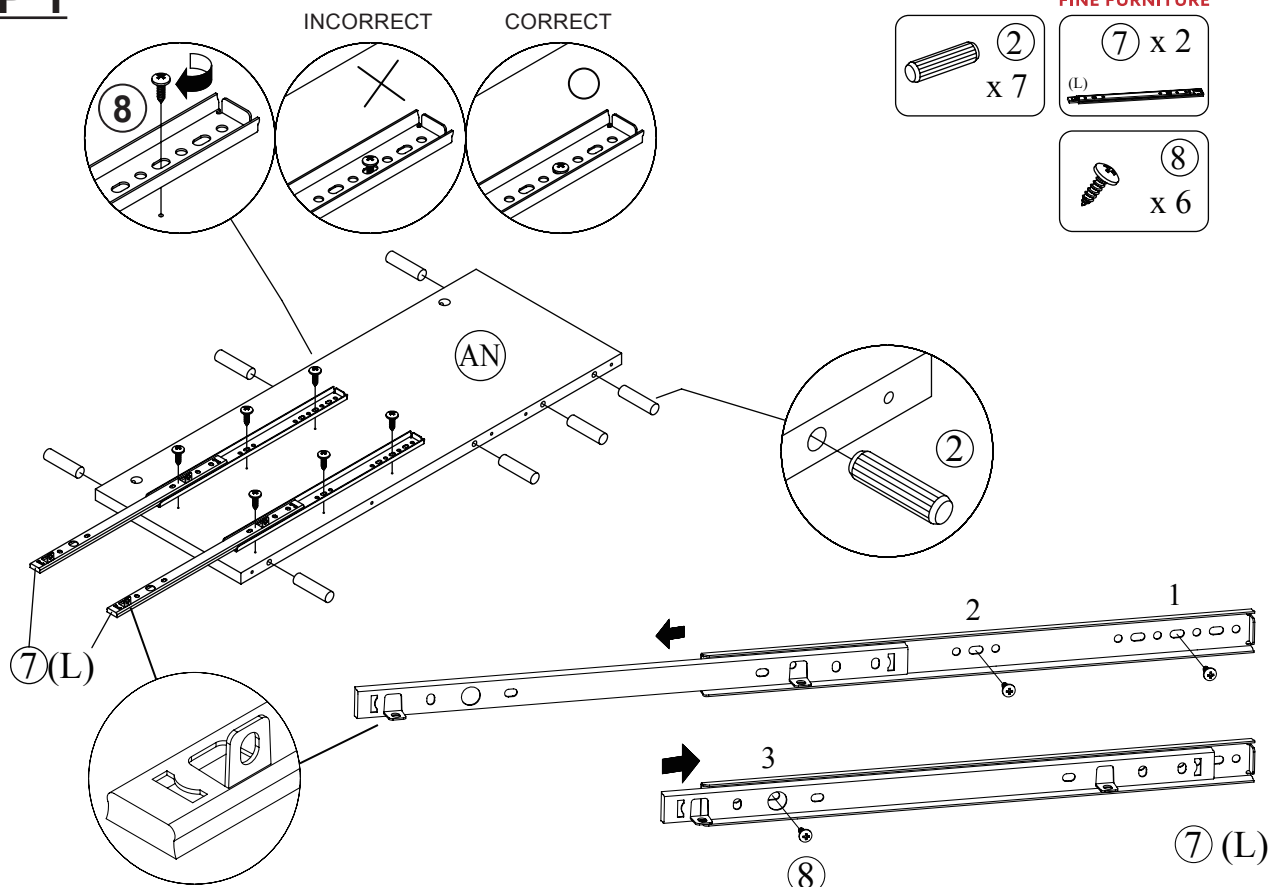

STEP 2

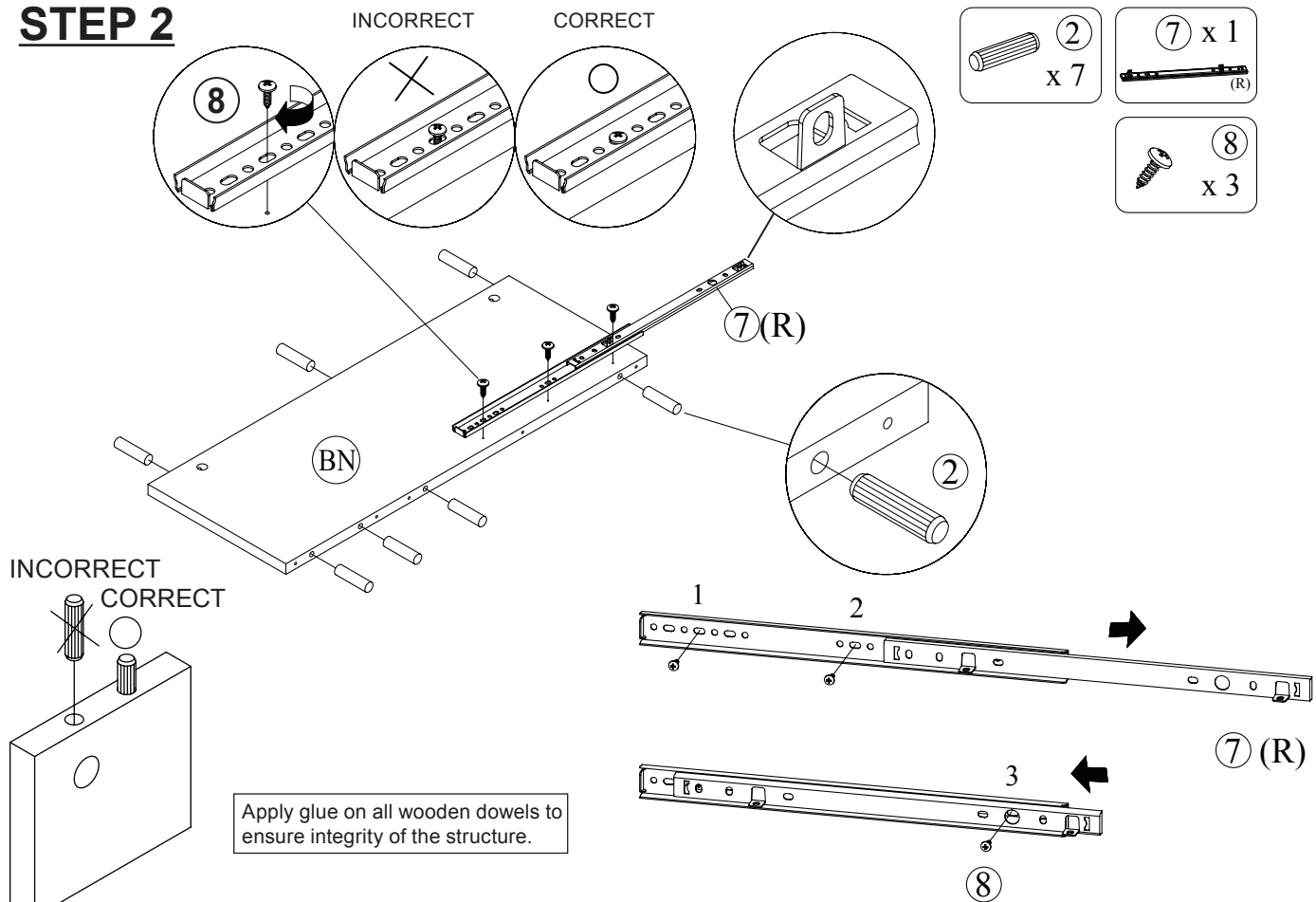

ITEM: 802999

COASTER

FINE FURNITURE

STEP 3

INCORRECT

CORRECT

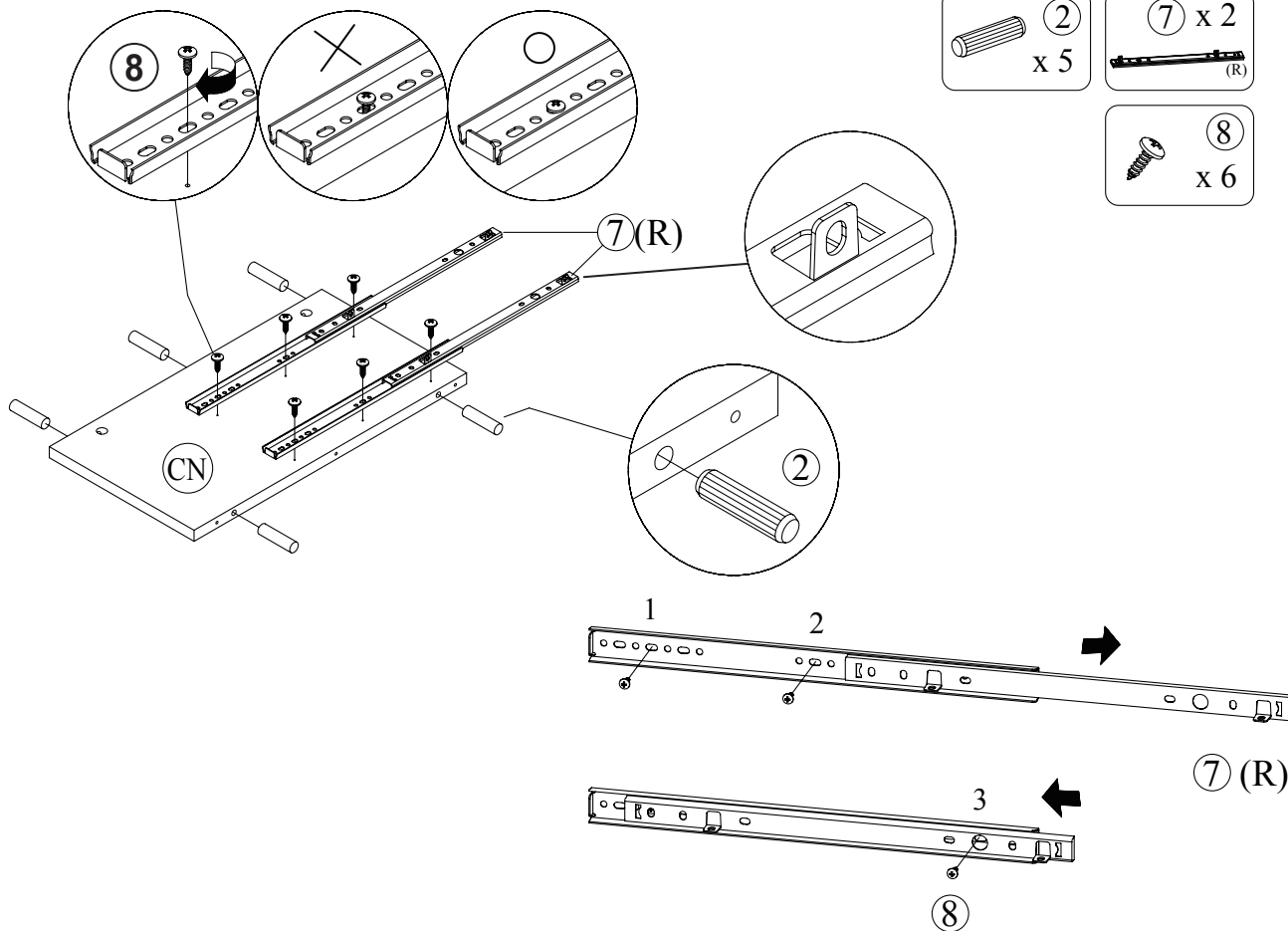

↓ the reverse side

INCORRECT

CORRECT

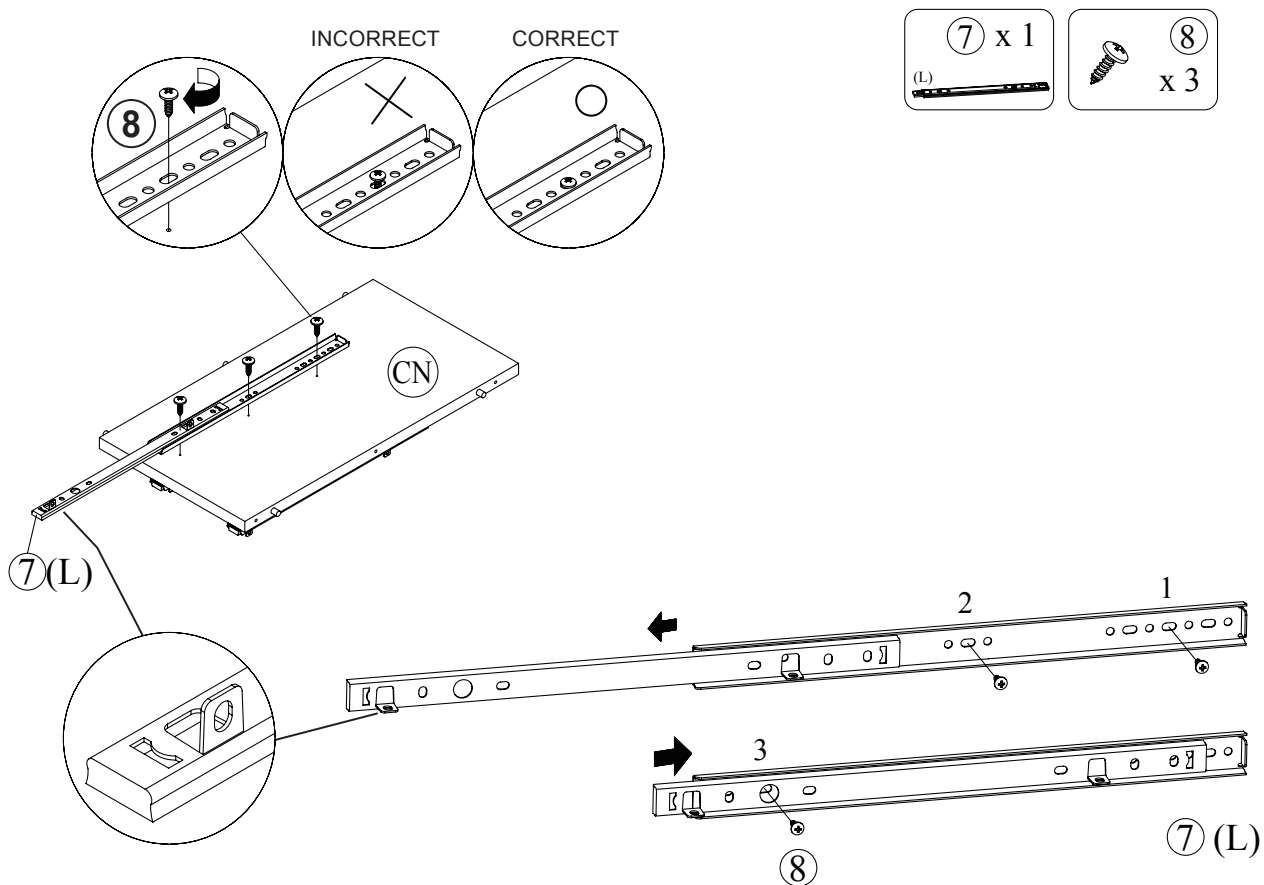

ITEM: 802999

COASTER
FINE FURNITURE

STEP 4

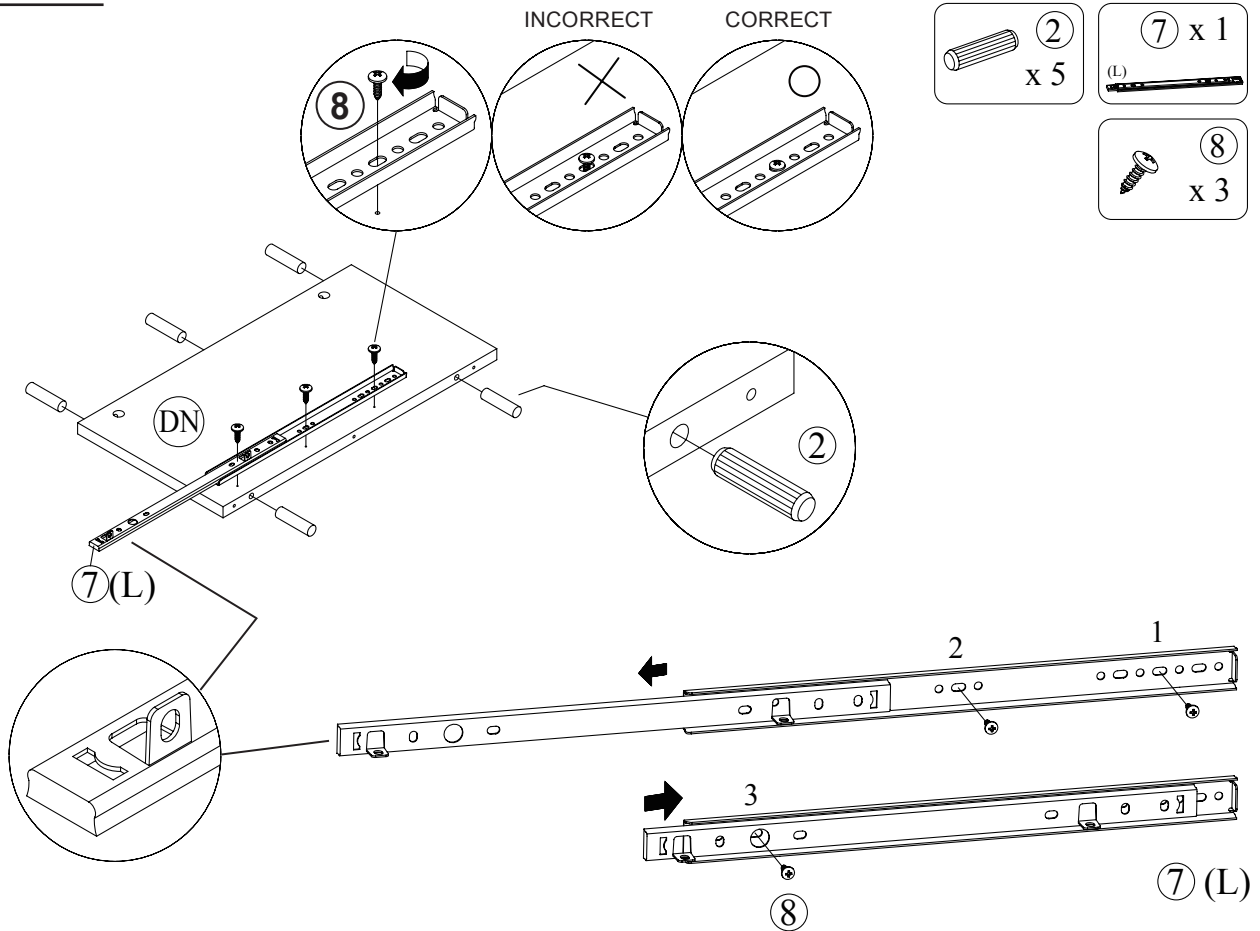

↓ **the reverse side**

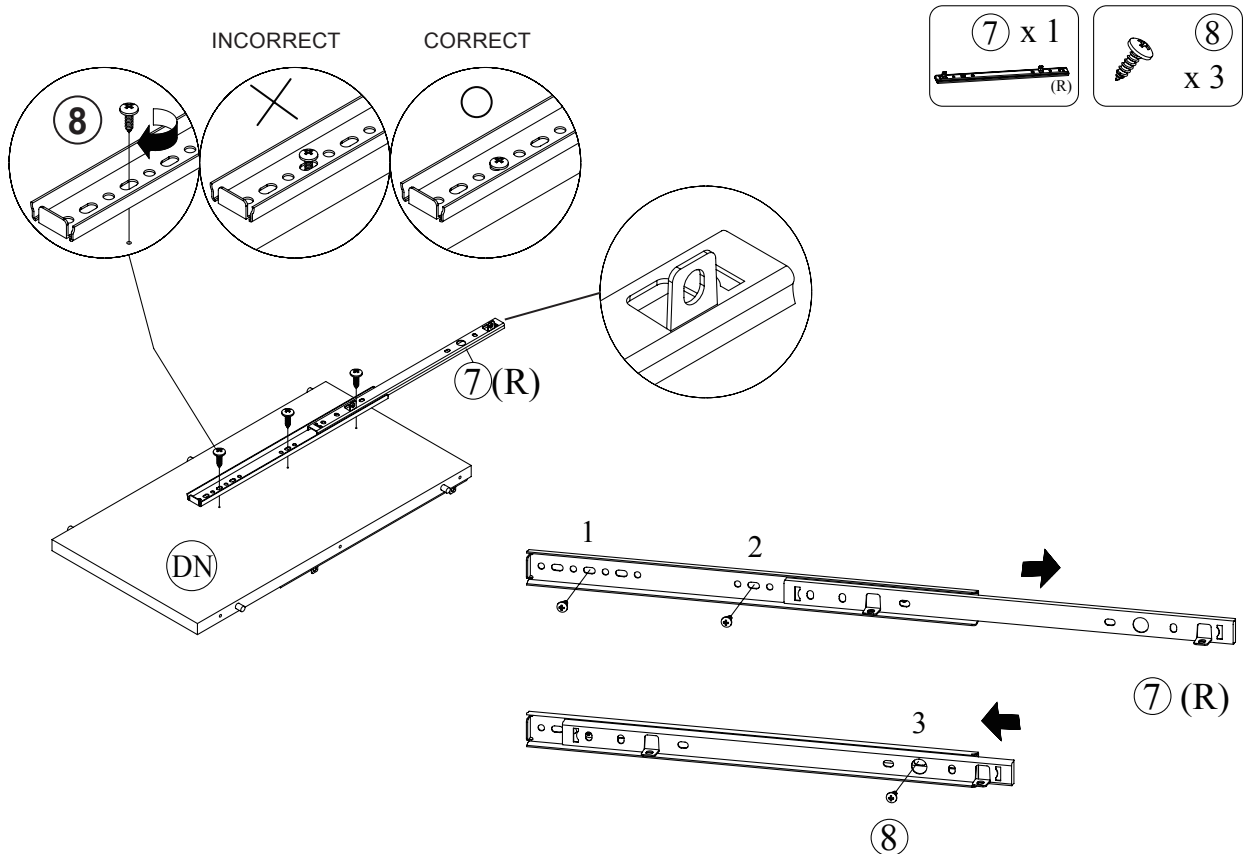

ITEM: 802999

COASTER
FINE FURNITURE

STEP 5

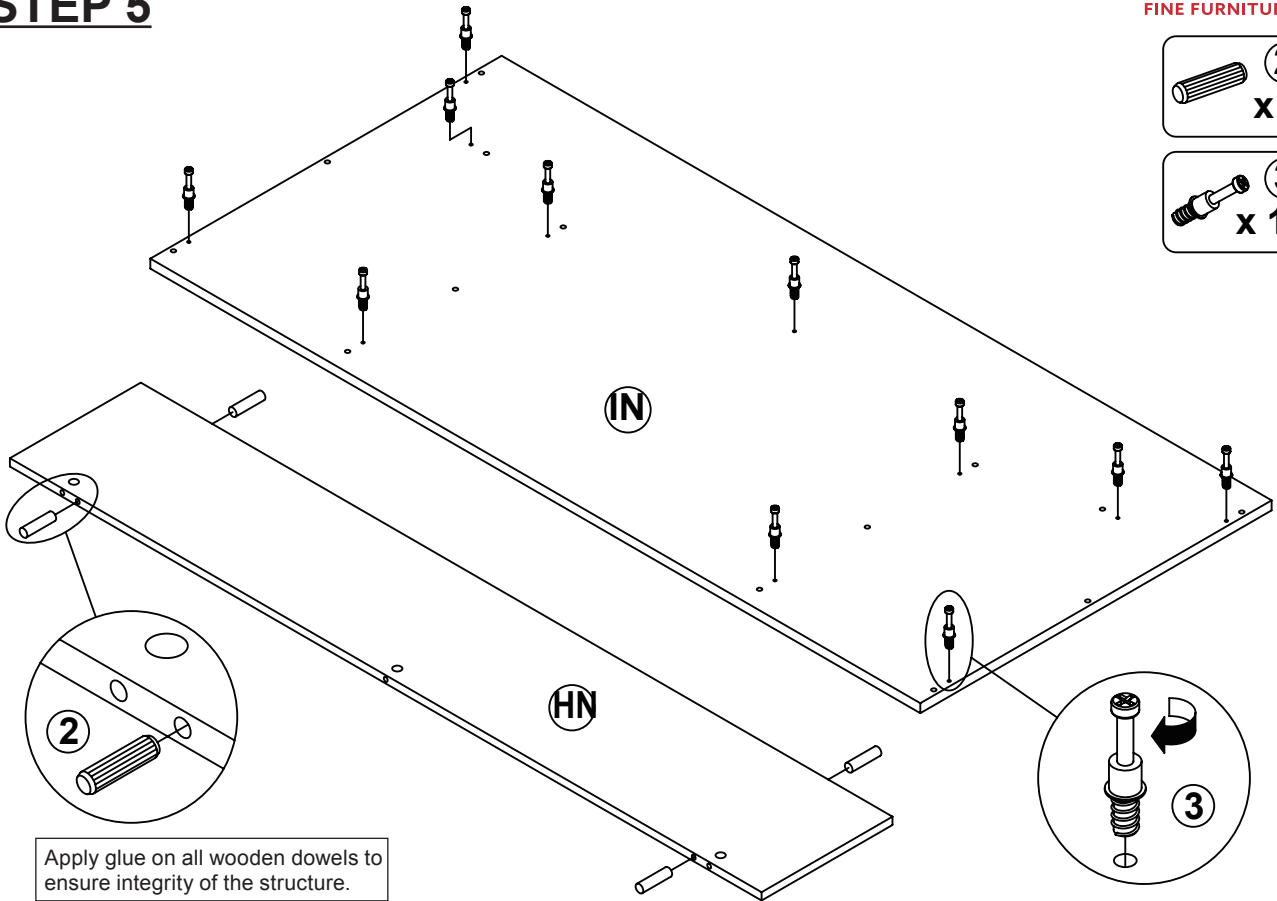
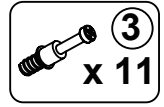
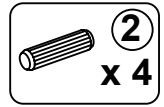

Apply glue on all wooden dowels to ensure integrity of the structure.

STEP 6

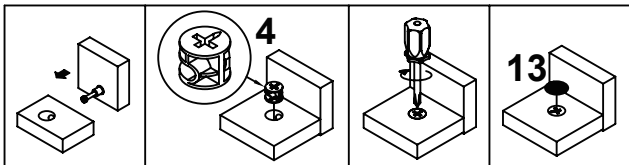
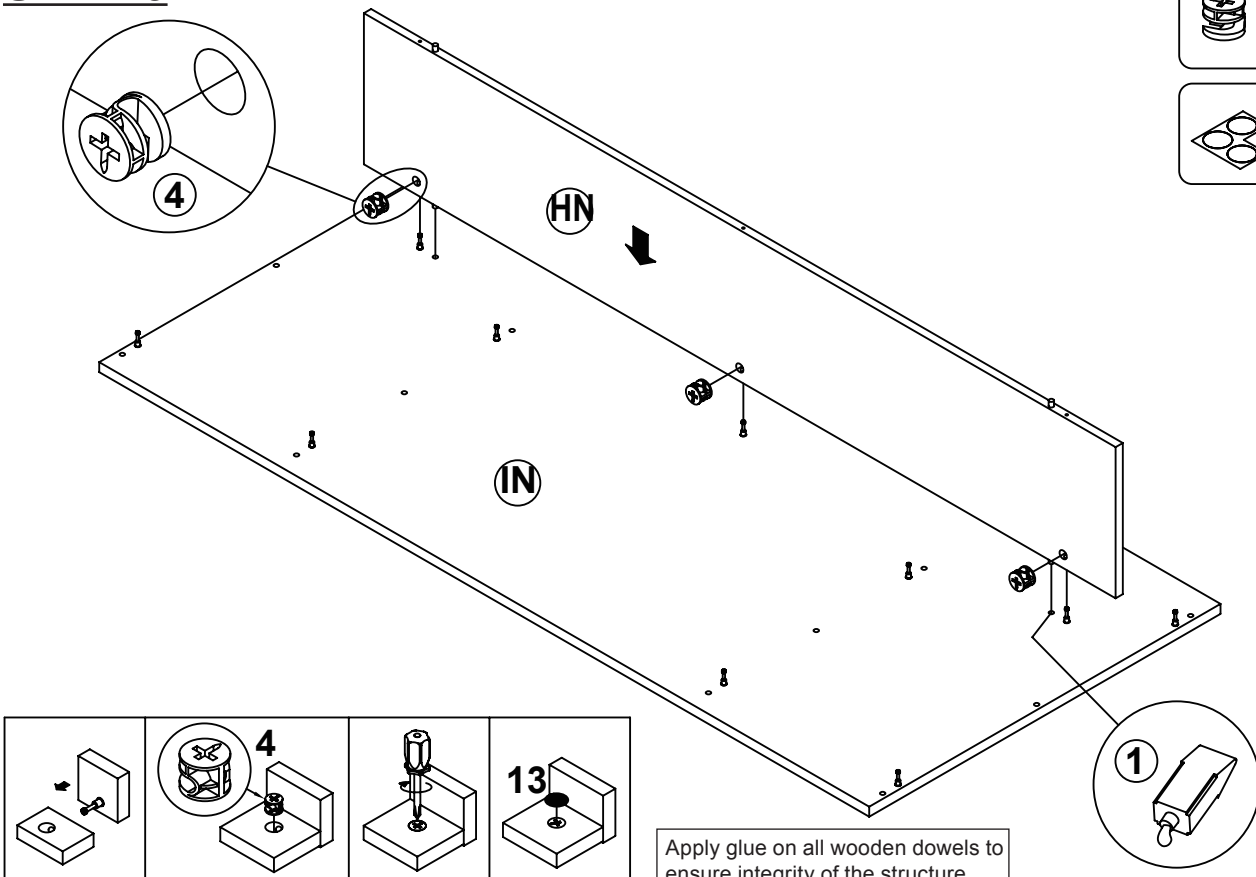
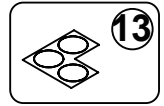
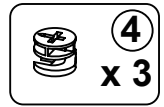

Apply glue on all wooden dowels to ensure integrity of the structure.

ITEM: 802999

COASTER

FINE FURNITURE

STEP 7

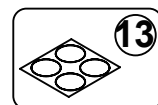
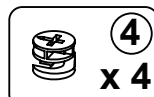
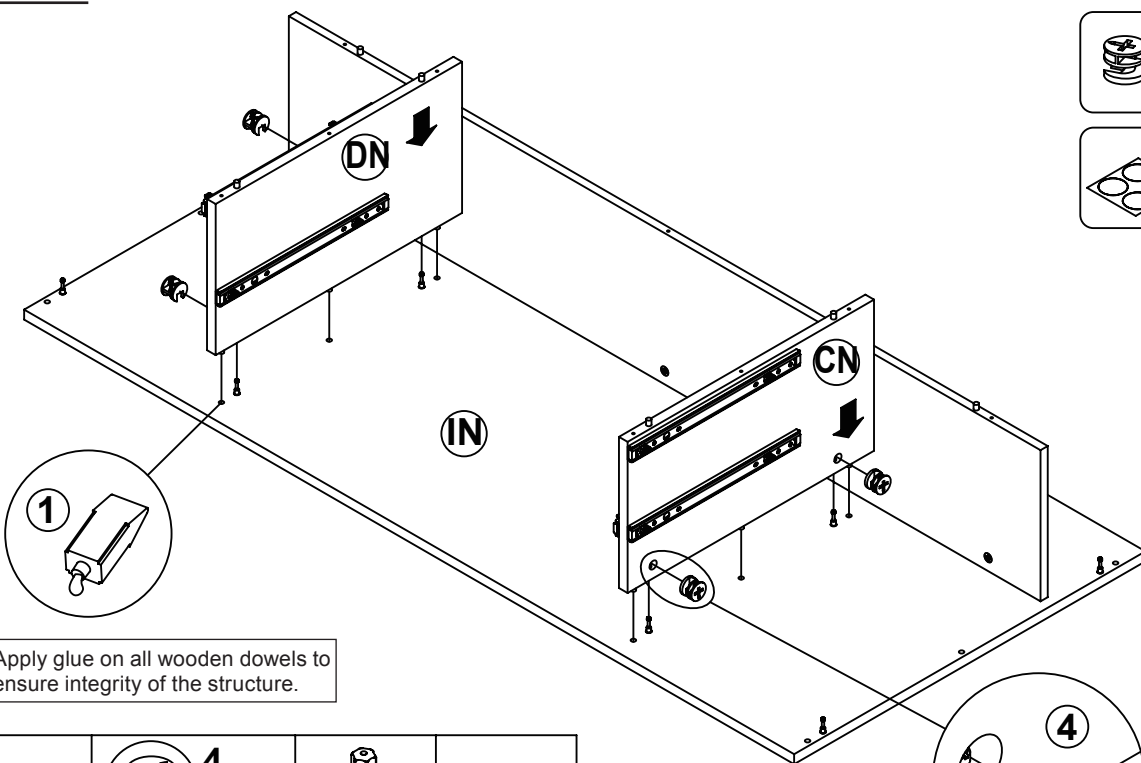

Apply glue on all wooden dowels to ensure integrity of the structure.

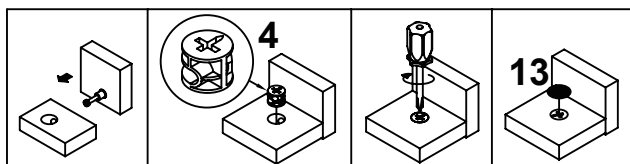

STEP 8

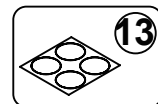
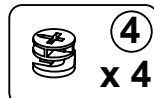
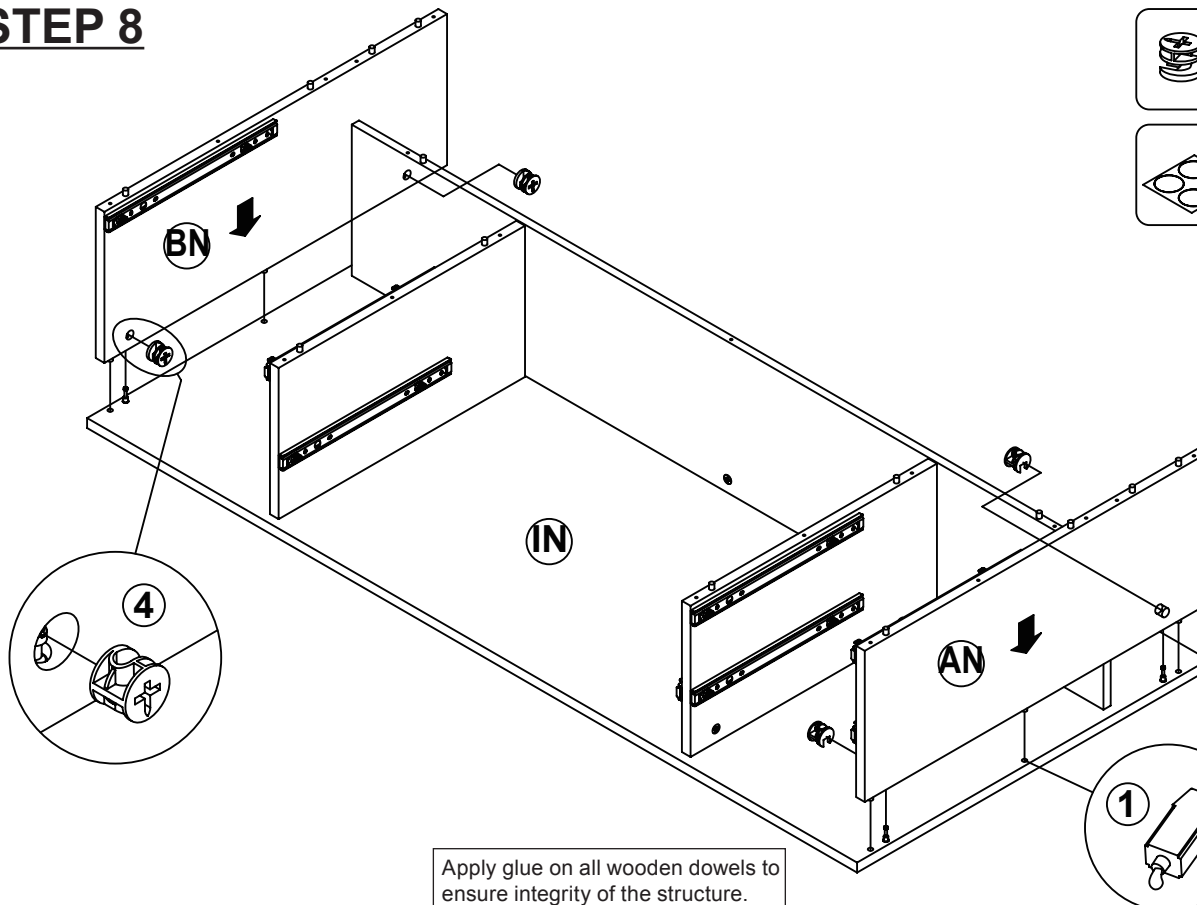

Apply glue on all wooden dowels to ensure integrity of the structure.

ITEM: 802999

COASTER
FINE FURNITURE

STEP 9

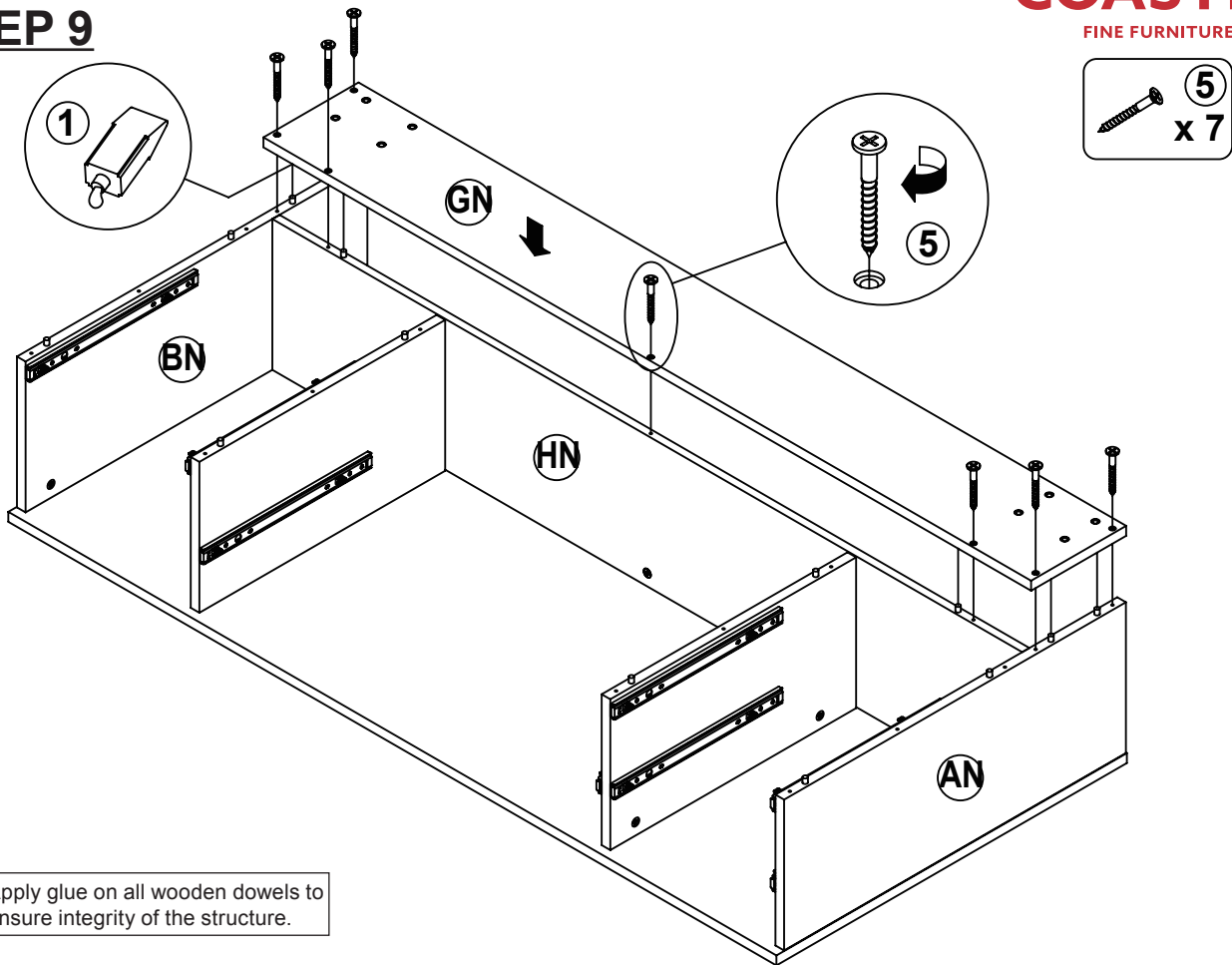

Apply glue on all wooden dowels to ensure integrity of the structure.

STEP 10

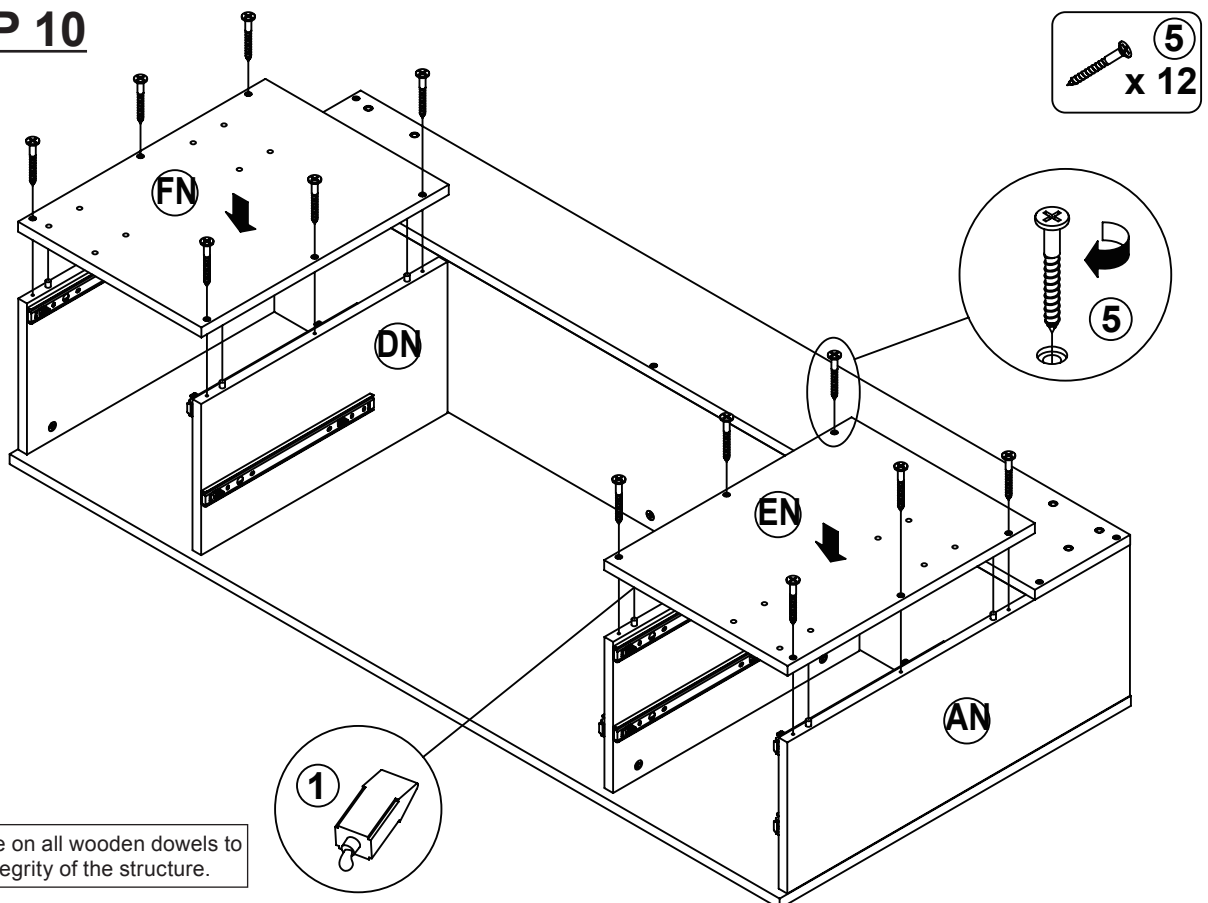

Apply glue on all wooden dowels to ensure integrity of the structure.

STEP 13

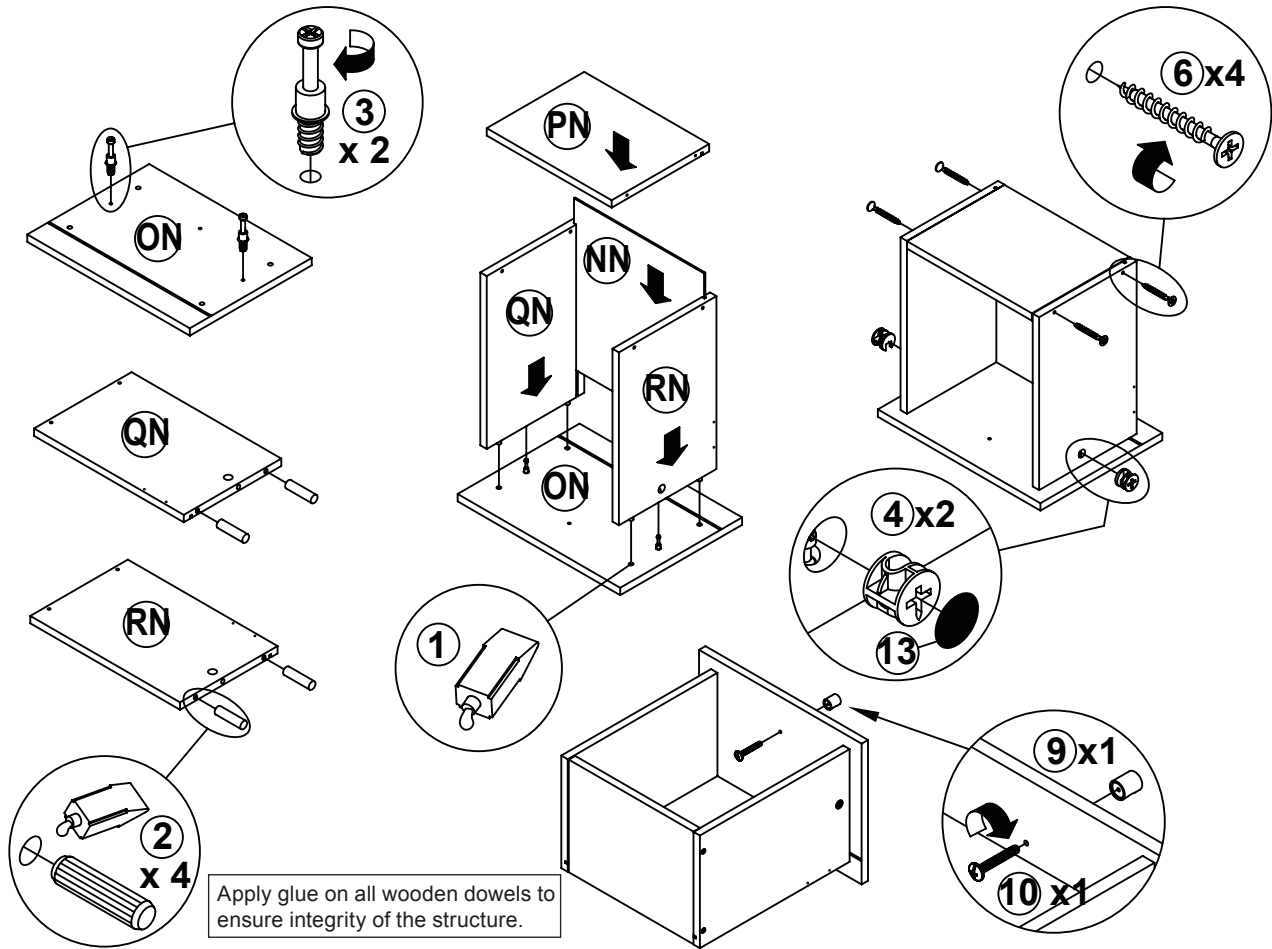

STEP 14

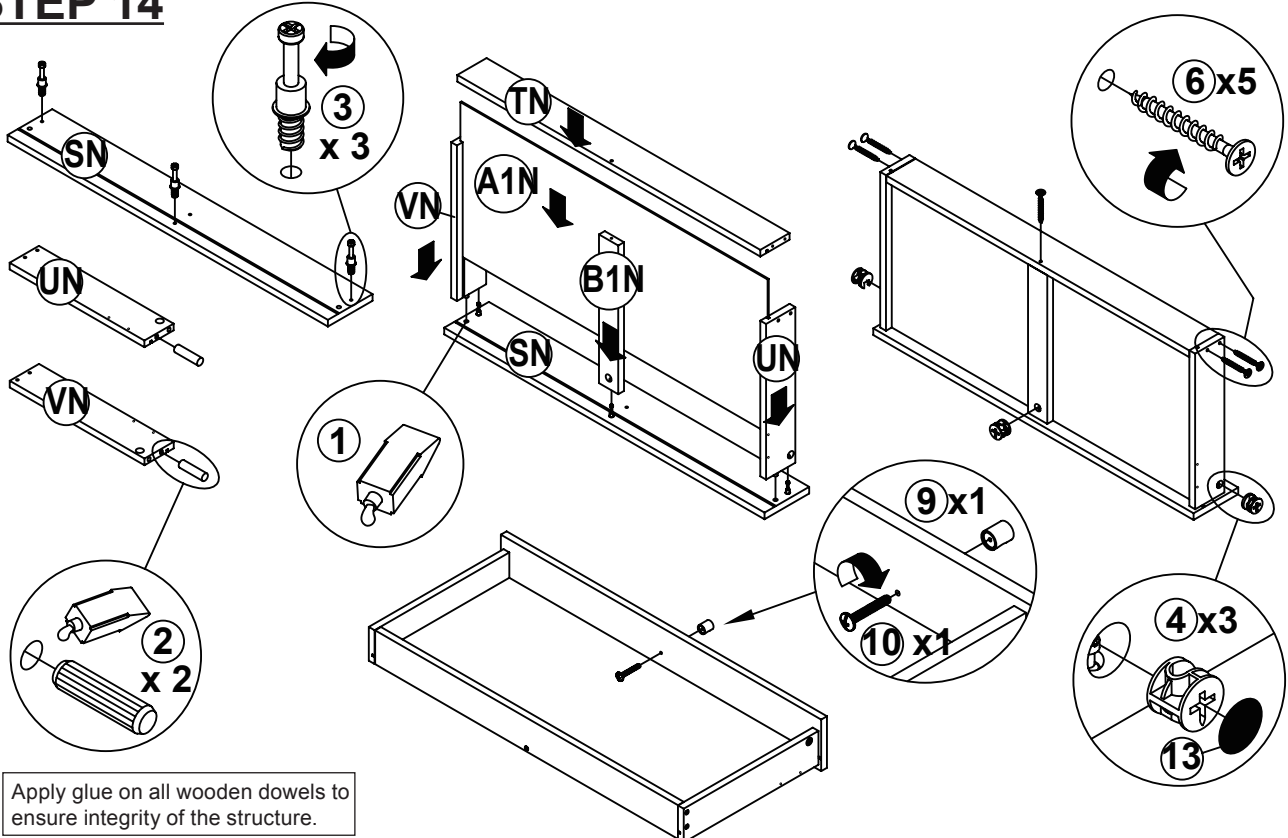

ITEM: 802999

STEP 15

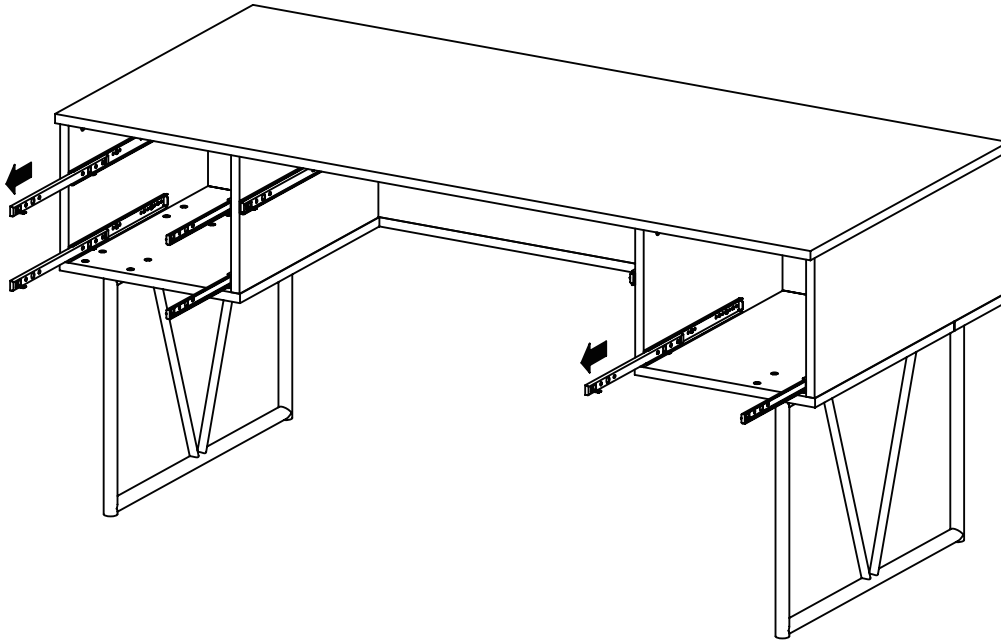

STEP 16

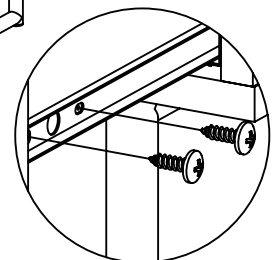
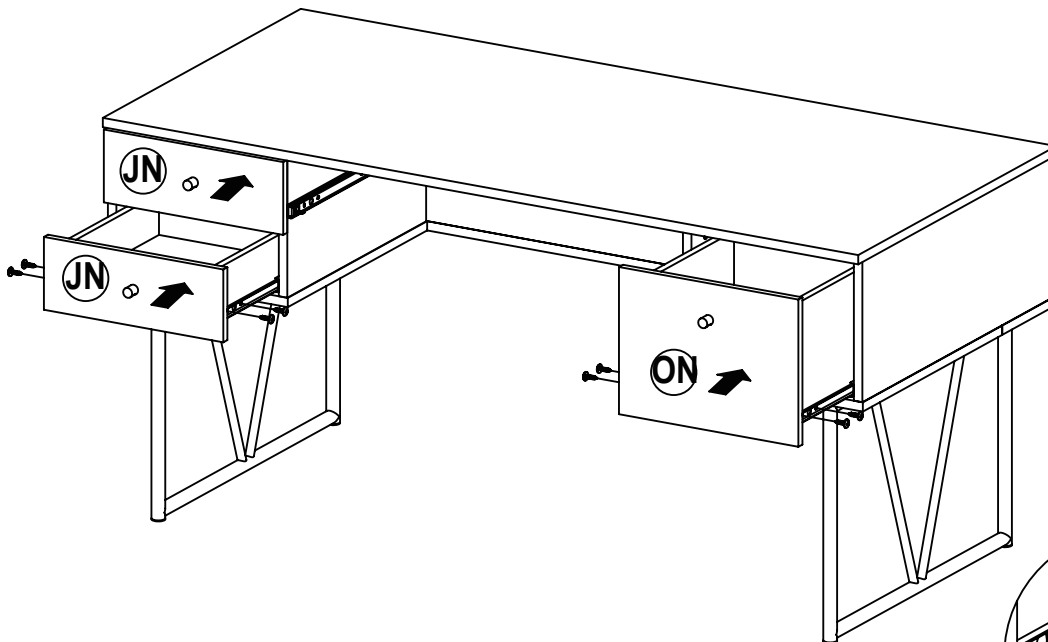
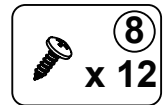

ITEM: 802999

STEP 17

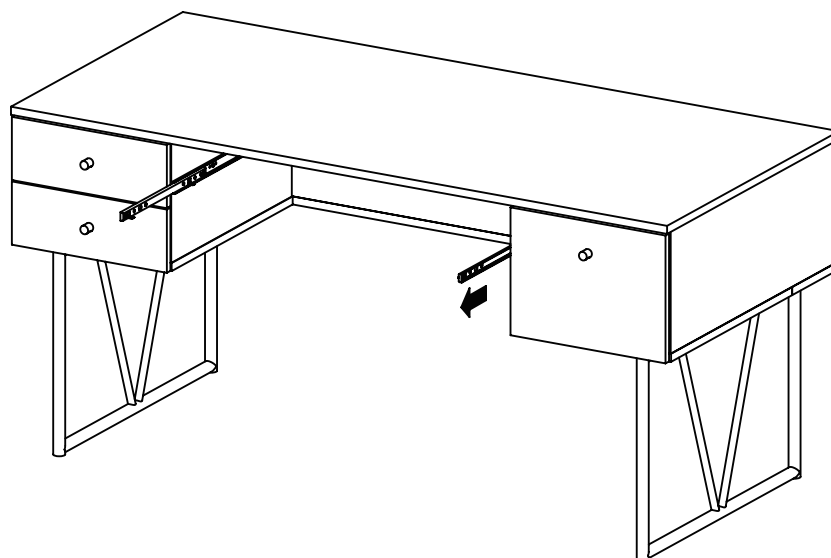

STEP 18

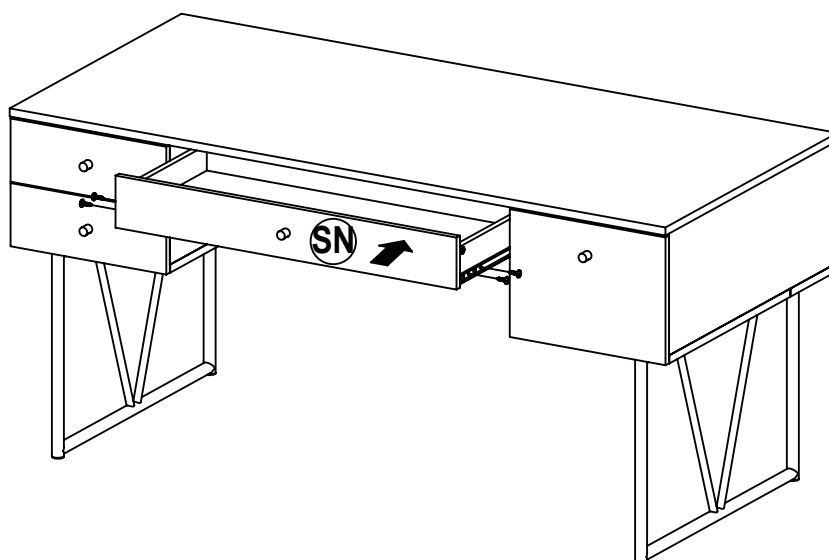
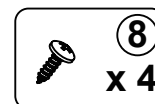

STEP 19
COMPLETE

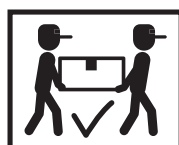
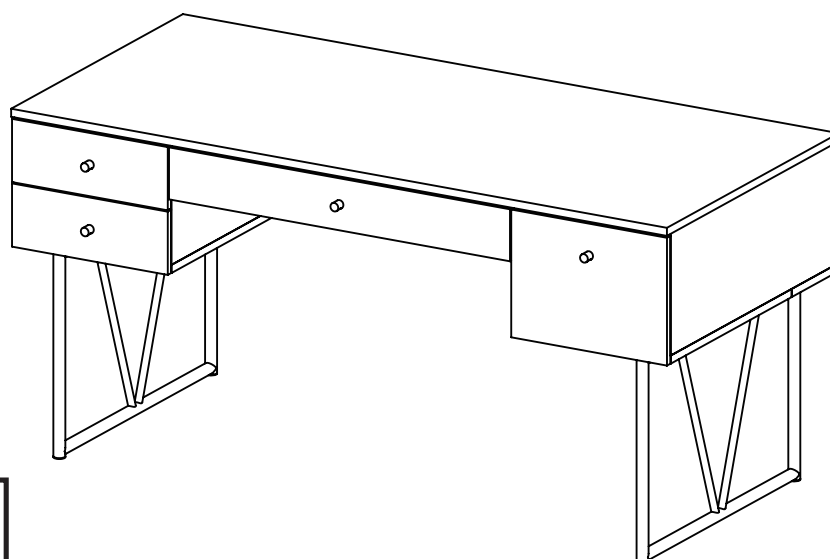

ITEM: 802999

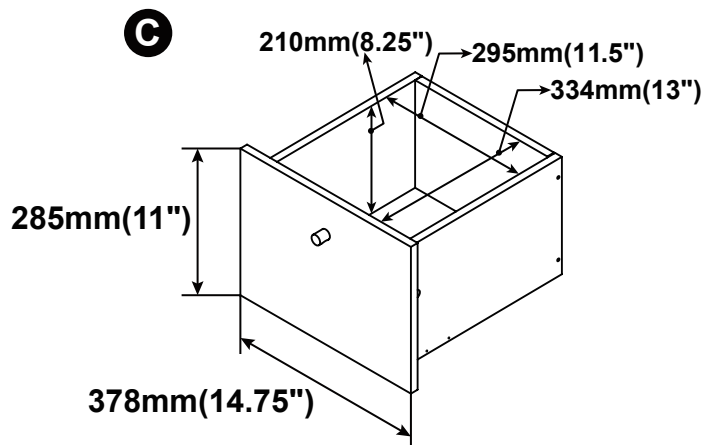
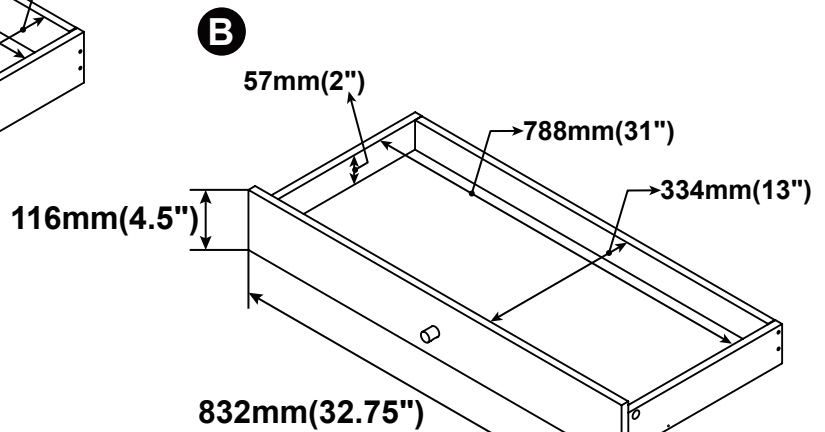
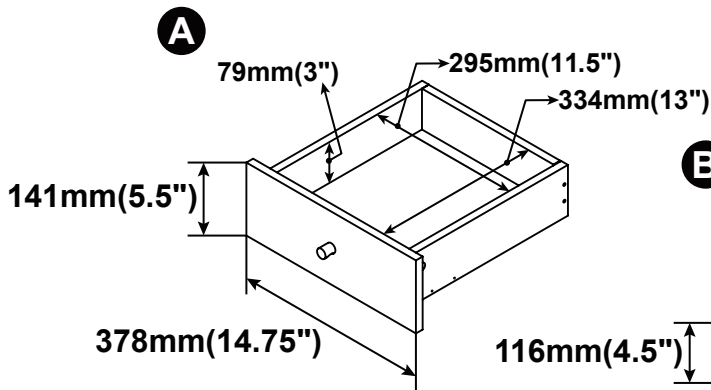
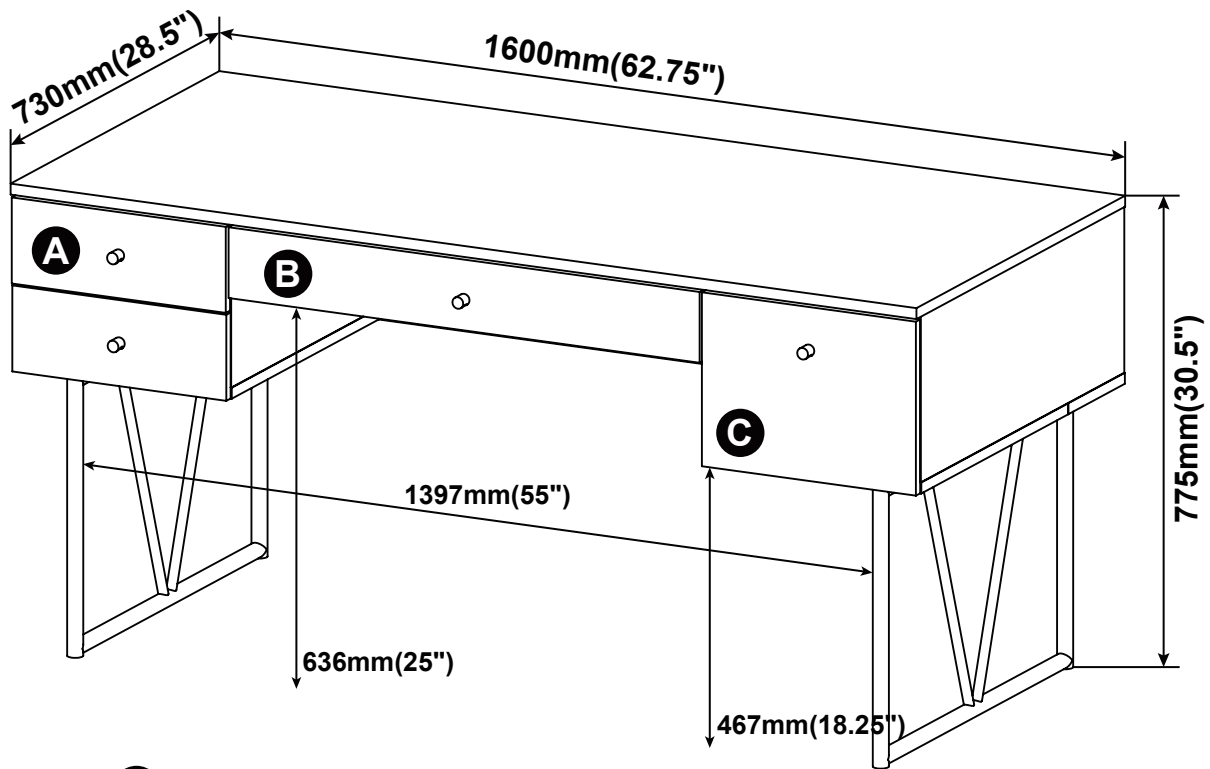

Note : Dimension tolerance $\pm 5\%$