



ASSEMBLY INSTRUCTIONS COASTER FINE FURNITURE



Fine Furniture for every stage of life

203481KW(B1-B3) California King Storage Bed

REVISION 0 : 05/01/2014
REVISION 1 : 05/15/2014
REVISION 2 : 11/04/2020

PAGE 1 OF 6

COASTERFURNITURE.COM

ITEM: 203481KW(B1-B3)



ASSEMBLY INSTRUCTIONS

ASSEMBLY TIPS:

1. Remove hardware from box and sort by size.
2. Please check to see that all hardware and parts are present prior to start of assembly.
3. Please follow attached instructions in the same sequence as numbered to assure fast & easy assembly.



WARNING !

1. Don't attempt to repair or modify parts that are broken or defective. Please contact the store immediately.
2. This product is for home use only and not intended for commercial establishment.



ASSEMBLY TIME



30 MINUTES



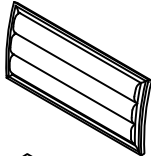
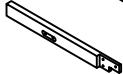
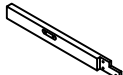
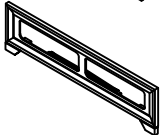
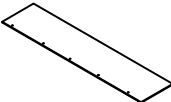

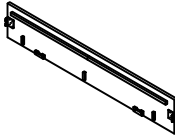
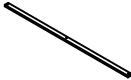
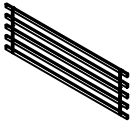

PARTS IDENTIFICATION

B1 (BOX 1)

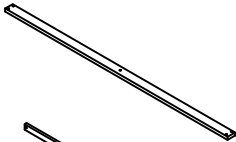
A	HEADBOARD PANEL		1PC
B	LEFT HEADBOARD LEG		1PC
C	RIGHT HEADBOARD LEG		1PC
D	FOOTBOARD		1PC
E	CONCEAL PANEL		1PC

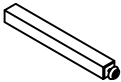
B2 (BOX 2)

F	BED RAIL		2PCS
G	BED SLAT WITH 3 HOLES		3PCS
H	ROLL SLAT (5PCS)		2SETS
I	CENTER RAIL		1PC

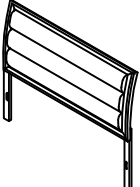
J	DRAWER BOTTOM TRESTLE BAR		1PC
K	BOTTOM CROSS BAR		2PCS
L	BED SLAT SUPPORT WITH LEVELER		3PCS
M	DRAWER BOTTOM TRESTLE BAR SUPPORT WITH LEVELER		1PC
N	UPPER TRESTLE SUPPORT BAR		1PC
O	RAIL CAP		2PCS
HB	203481KW (B1) FROM BOX 1 HEADBOARD		1PC

B3 (BOX 3)

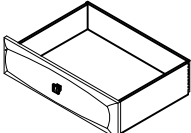
P	FOOTBOARD DRAWER BOX		2PCS
---	----------------------	---	------

ITEM: 203481KW(B1-B3)



ASSEMBLY INSTRUCTIONS

ASSEMBLY TIPS:

- 1 . Remove hardware from box and sort by size.
- 2 . Please check to see that all hardware and parts are present prior to start of assembly.
- 3 . Please follow attached instructions in the same sequence as numbered to assure fast & easy assembly.



WARNING !

- 1 . Don't attempt to repair or modify parts that are broken or defective. Please contact the store immediately.
- 2 . This product is for home use only and not intended for commercial establishment.







ASSEMBLY TIME









30 MINUTES

HARDWARE IDENTIFICATION

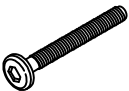
Z-B1 (BOX 1) - HARDWARE PACK IS LOCATED IN 203481KW (B1)

1	BOLT (M6 x 30mm - BLK)		6PCS	3	LOCK WASHER (1/4" - BLK)		6PCS
2	ALLEN WRENCH (M4 x 65mm - BLK)		6PCS	4	FLAT WASHER (1/4" x 13mm - BLK)		6PCS

Z-B2 (BOX 2) - HARDWARE PACK IS LOCATED IN 203481KW (B2)

5	SHORT BOLT (M6 x 35mm - BLK)		10PCS	9	SMALL ALLEN WRENCH (M4 x 65mm - BLK)		7PCS
6	LONG BOLT (M6 x 50mm - BLK)		4PCS	10	LONG FLAT HEAD SCREW (M4 x 16mm - RBW)		36PCS
7	SMALL ALLEN WRENCH (M4 x 65mm - BLK)		1PC	11	LOCK WASHER (1/4" - BLK)		10PCS
8	BIG ALLEN WRENCH (M5 x 65mm - BLK)		1PC	12	FLAT WASHER (1/4" x 13mm - BLK)		10PCS

NOTE:

Philips head screw driver in the assembly process ; however, manufacturer does not provide the item

ITEM: 203481KW(B1-B3)

ASSEMBLY INSTRUCTIONS



STEP 1

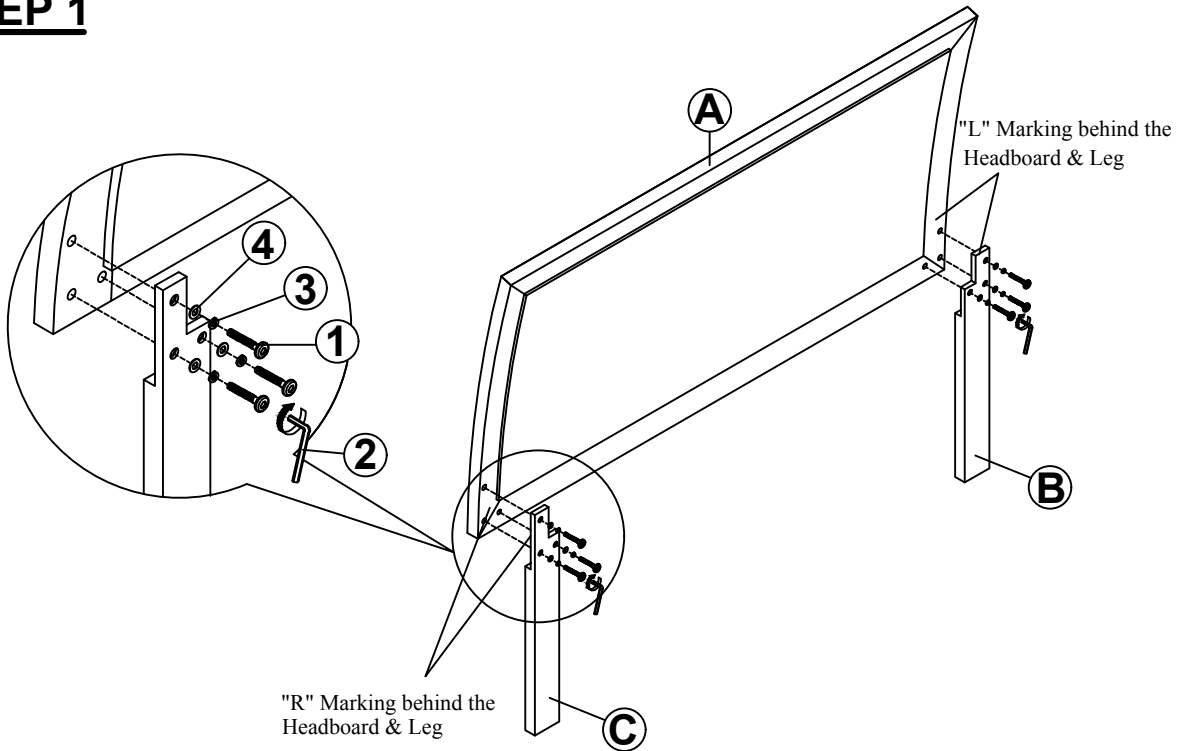

STEP 2

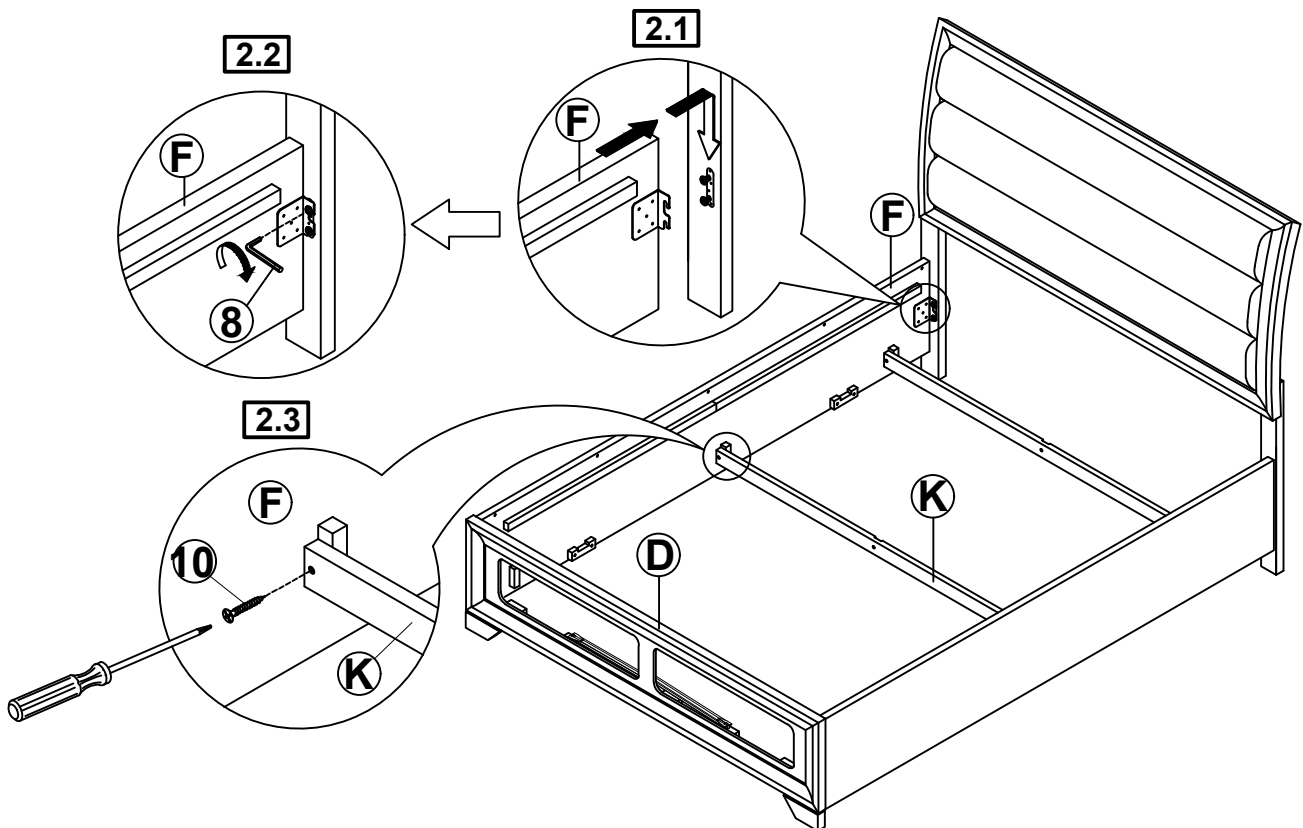

ITEM: 203481KW(B1-B3)

ASSEMBLY INSTRUCTIONS



STEP 3

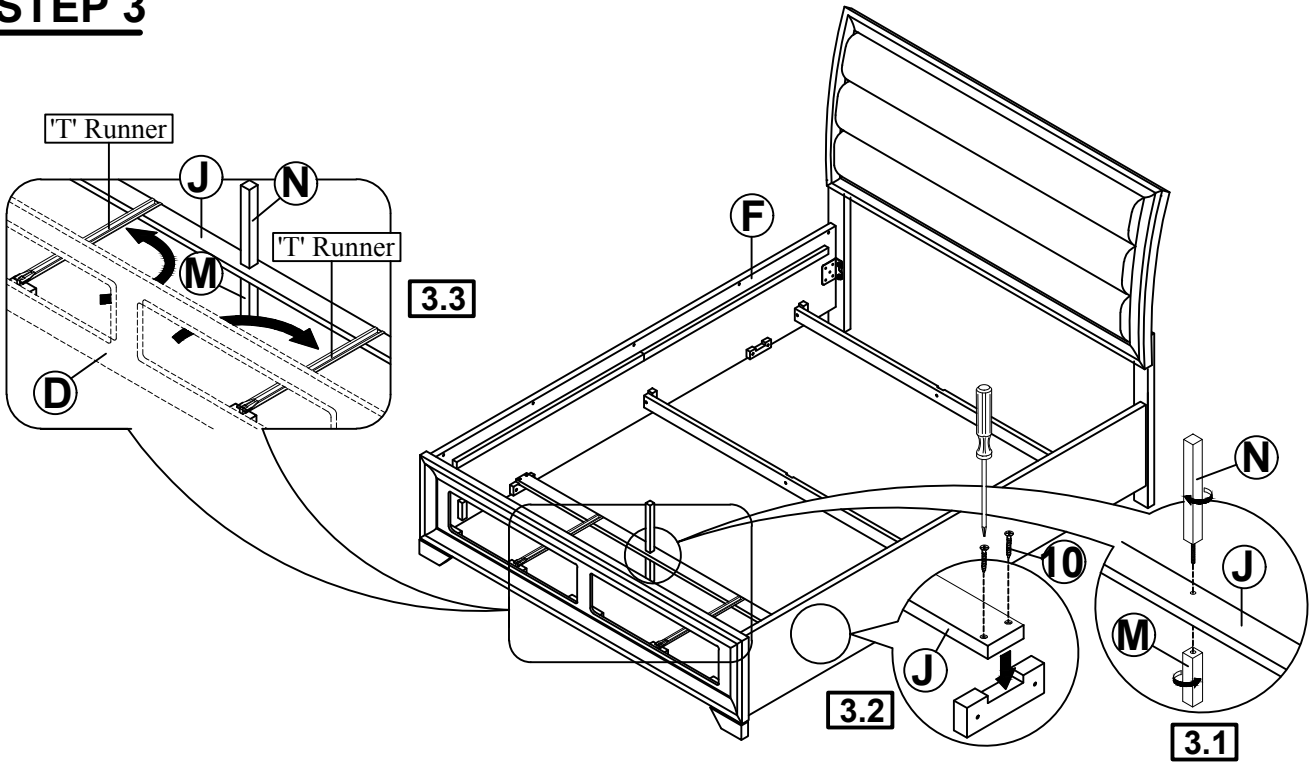

STEP 4

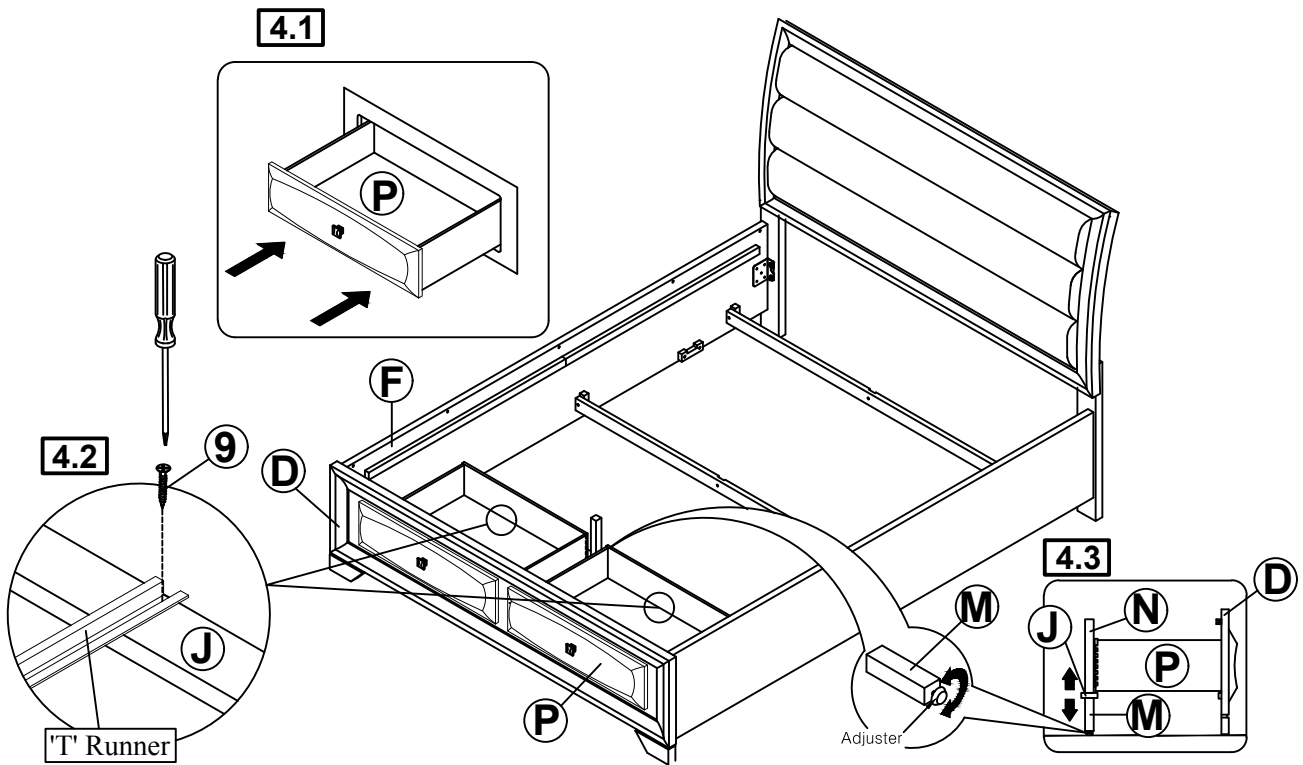

ITEM: 203481KW(B1-B3)

ASSEMBLY INSTRUCTIONS



STEP 5

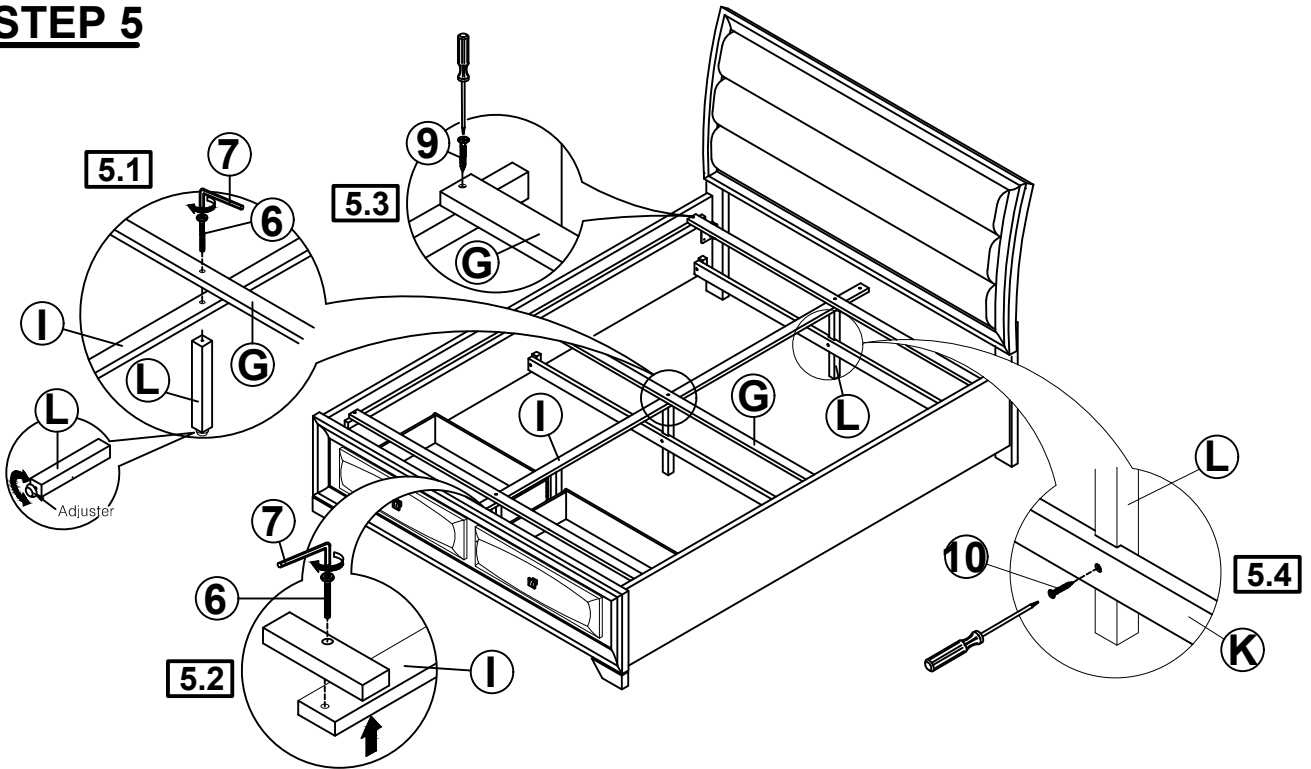

STEP 6 COMPLETE

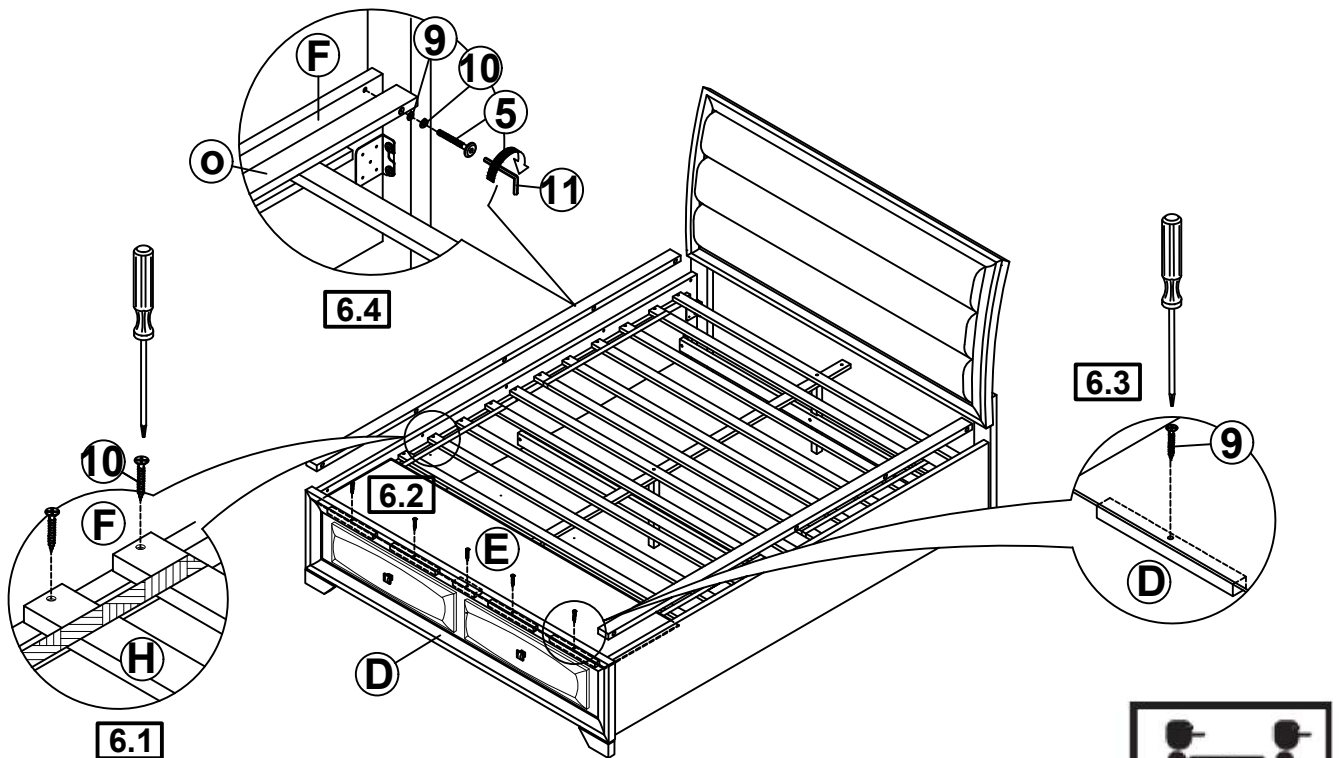

ITEM: **203481KW(B1-B3)**



INNER SIZE : 76.57" X 86.02"

INNER SIZE DRAWER : 5.28" X 17.01" X 24.02"

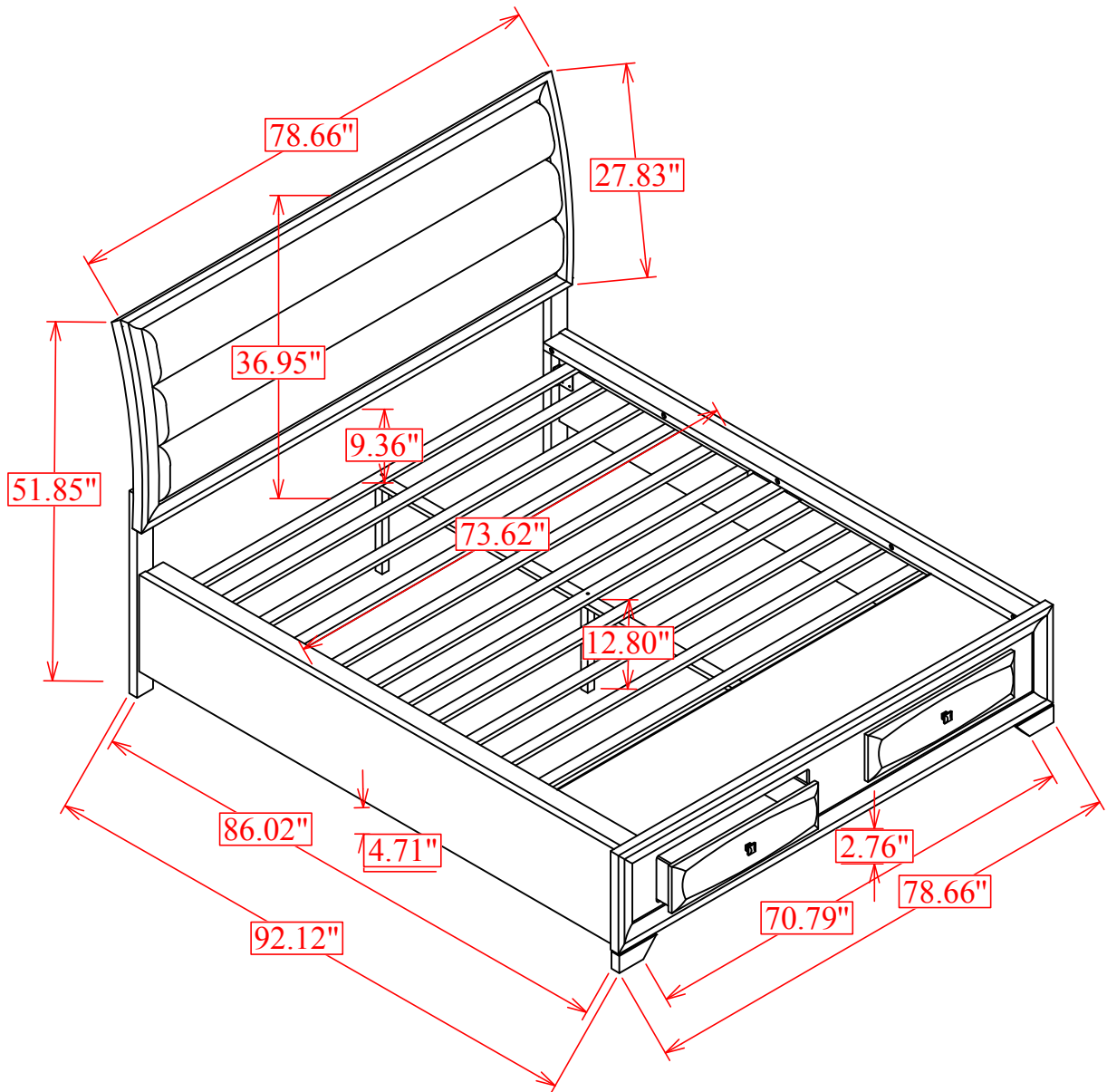

Note: Dimension tolerance $\pm 5\%$