



ASSEMBLY INSTRUCTIONS COASTER FINE FURNITURE



Fine Furniture for every stage of life

110078
Bench

REVISION 0 : 10/24/2020
REVISION 1 : 01/02/2021

PAGE 1 OF 3

COASTERFURNITURE.COM

ASSEMBLY INSTRUCTIONS

ASSEMBLY TIPS :

1. Remove hardware from box and sort by size.
2. Please check to see that all hardware and parts are present prior to start of assembly.
3. Please follow attached instructions in the same sequence as numbered to assure fast & easy assembly.



WARNING!



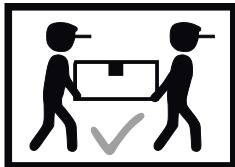



1. Don't attempt to repair or modify parts that are broken or defective. Please contact the store immediately.
2. This product is for home use only and not intended for commercial establishments.



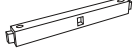

ASSEMBLY TIME

15 MINUTES

PARTS IDENTIFICATION

A	SEAT		1PC
B	LEFT FRONT LEG		1PC
C	LEFT BACK LEG		1PC
D	RIGHT FRONT LEG		1PC
E	RIGHT BACK LEG		1PC
F	SIDE STRETCHER		2PCS
G	CENTER STRETCHER		1PC

HARDWARE IDENTIFICATION

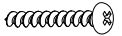
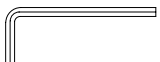
1	BOLT (Ø5/16" x 2"- BLK)		8PCS
2	LOCK WASHER (Ø5/16" - RBW)		8PCS
3	FLAT WASHER (Ø5/16" - RBW)		8PCS
4	PAN HEAD SCREW (Ø8 x 50MM - RBW)		6PCS
5	ALLEN WRENCH (6MM - BLK)		1PC

NOTE:

Quantities shown are for one bench.

Phillips head screw driver is required in the assembly process; however, manufacturer does not provide this item.

ITEM : **110078**

ASSEMBLY INSTRUCTIONS

STEP 1

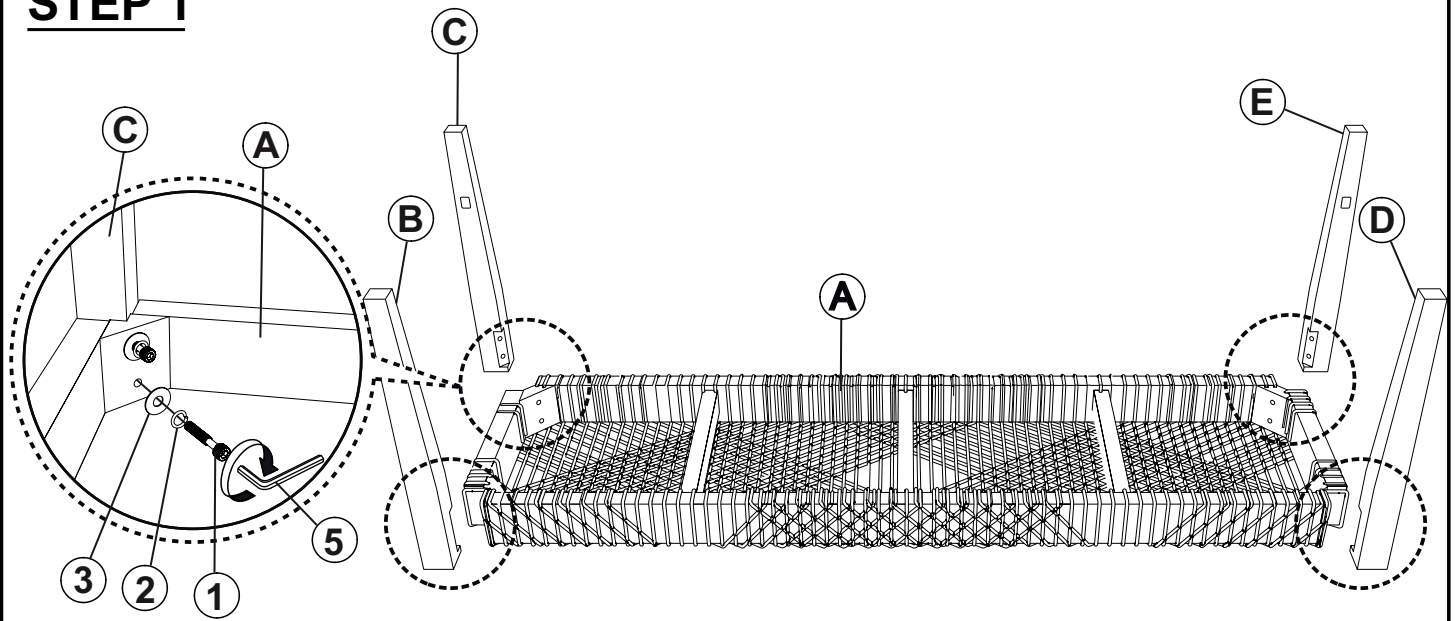

STEP 2

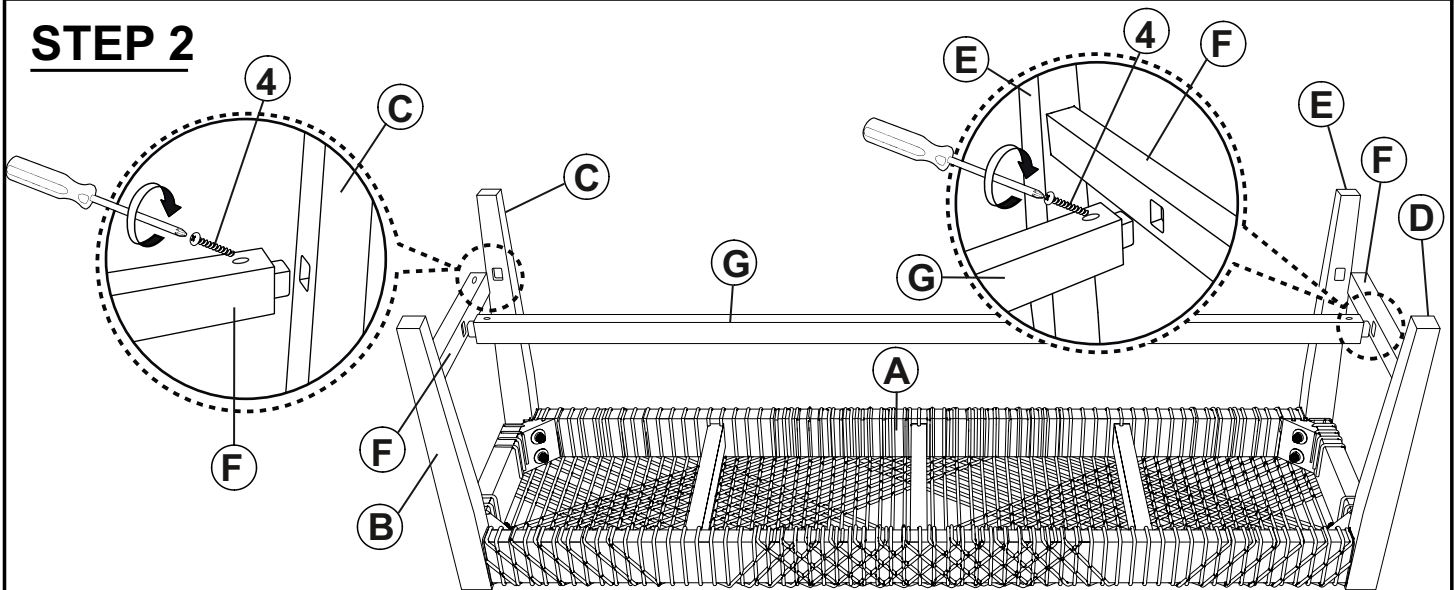

STEP 3

COMPLETE

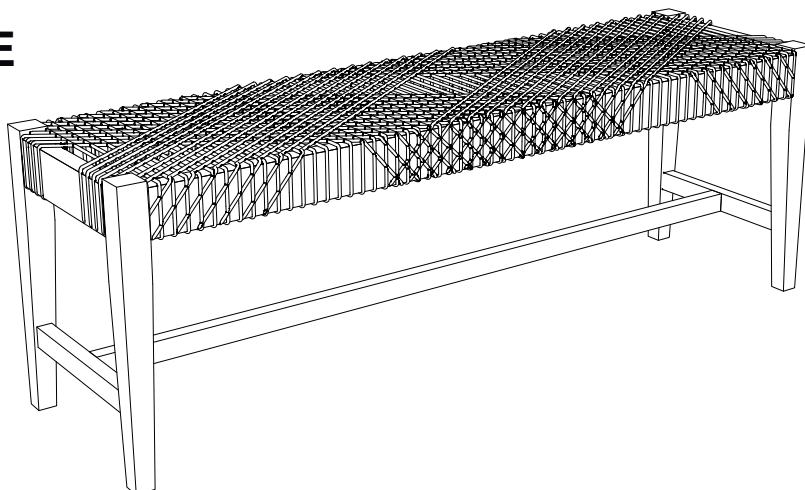

ITEM : **110078**

COASTER
FINE FURNITURE

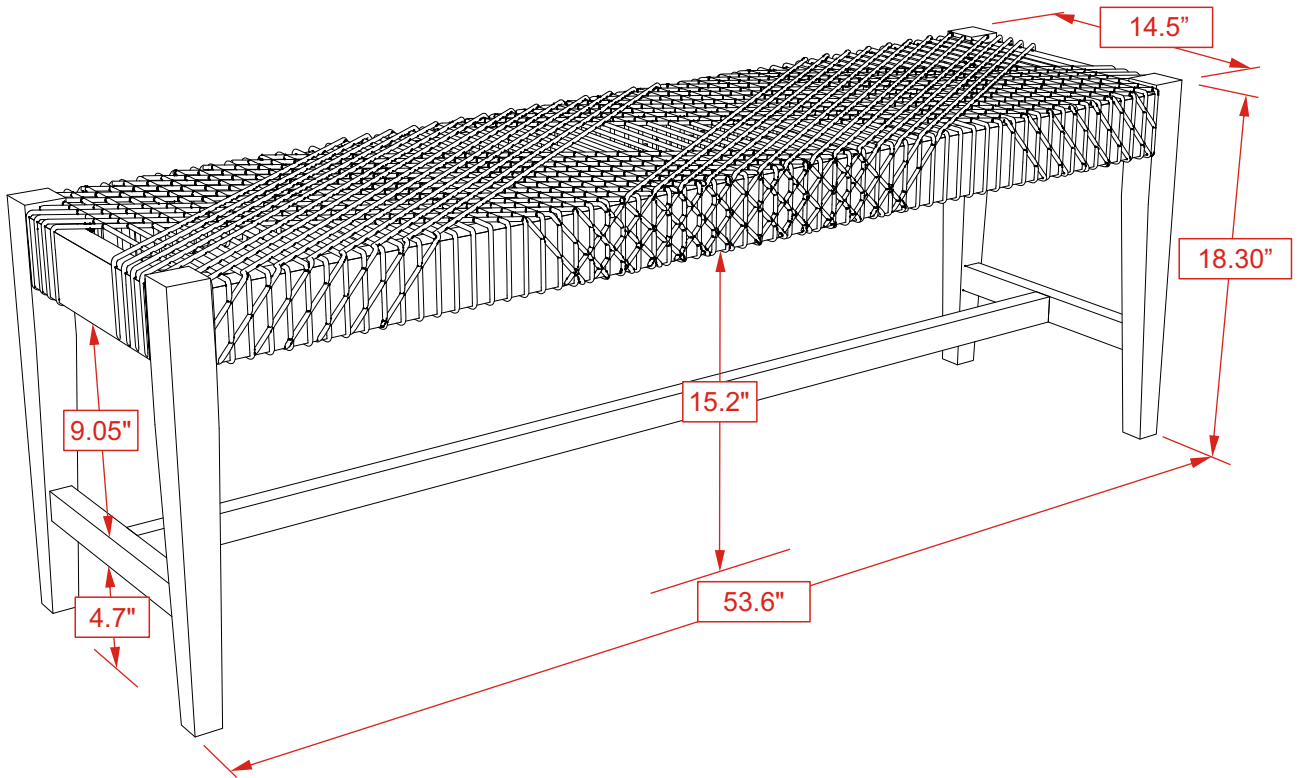

Note : Dimension tolerance $\pm 5\%$