

ASSEMBLY INSTRUCTIONS
COASTER FINE FURNITURE



Fine Furniture for every stage of life

182235
BAR UNIT

ITEM:182235



ASSEMBLY INSTRUCTIONS

ASSEMBLY TIPS:

1. Remove hardware from box and sort by size.
2. Please check to see that all hardware and parts are present prior to start of assembly.
3. Please follow attached instructions in the same sequence as numbered to assure fast & easy assembly.



WARNING!





1. Don't attempt to repair or modify parts that are broken or defective. Please contact the store immediately.
2. This product is for home use only and not intended for commercial establishments.



ASSEMBLY TIME 80 MINUTES

PARTS IDENTIFICATION

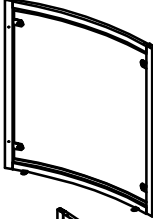
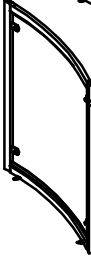
B1 : ACRYLIC PANELS, MIDDLE PANELS, DRAWER, METAL

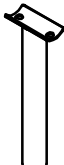



A	LEFT FRAME		1PC
B	RIGHT FRAME		1PC
C	FRONT RIGHT FRAME		1PC
D	FRONT LEFT FRAME		1PC
E	TOP GLASS SUPPORT LEG		5PCS
F	FOOTREST SIDE LEG		2PCS

ITEM:182235

ASSEMBLY INSTRUCTIONS

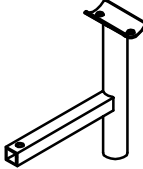
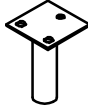
PARTS IDENTIFICATION

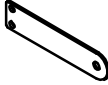
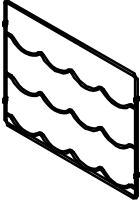
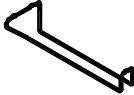





G	FOOTREST MIDDLE LEG		1PC
H	BOTTOM LEG		5PCS
I	FOOTREST MIDDLE LEG SUPPORT		1PC
J	FOOTREST PLATE		2PCS
K	BOTTLE RACK		2PCS
L	GLASS HOLDER		4PCS
M	LEFT PANEL		1PC

ITEM:182235

ASSEMBLY INSTRUCTIONS

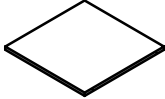
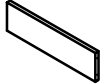
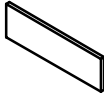
PARTS IDENTIFICATION



N	RIGHT PANEL		1PC
O	MIDDLE SHELF		1PC
P	BACK PANEL		1PC
Q	DRAWER FRONT PANEL		1PC
R	DRAWER BACK PANEL		1PC
S	DRAWER LEFT PANEL		1PC
T	DRAWER RIGHT PANEL		1PC

ITEM:182235 ASSEMBLY INSTRUCTIONS



U DRAWER BOTTOM PANEL

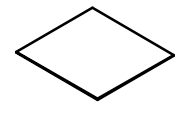

1PC

V SLIDE RAIL

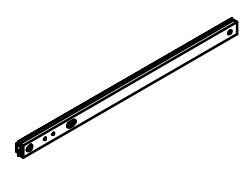

2PCS

B2 : GLASSES, TOP/BOTTOM PANELS, FOOTREST

A1 FOOTREST BAR

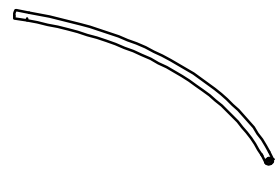

1PC

A2 TOP GLASS

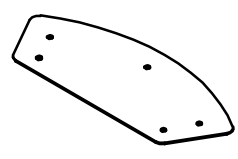

1PC

A3 SHELF GLASS



2PCS

A4 TOP PANEL

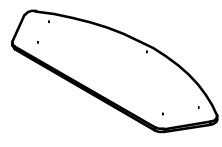

1PC

A5 BOTTOM PANEL

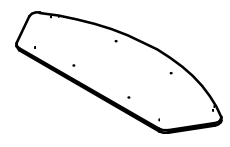





















1PC

ITEM:182235

ASSEMBLY INSTRUCTIONS

HARDWARE IDENTIFICATION



1	LONG BOLT (ϕ 1/4" x 32mm SR)		11PCS	11	CAM LOCK (ϕ 15mm)		6PCS
2	MEDIUM BOLT (ϕ 1/4" x 28mm SR)		8PCS	12	SHELF GLASS BOLT		8PCS
3	BOLT (ϕ 1/4" x 25mm SR)		1PC	13	WOOD DOWEL (8 x 30mm)		2PCS
4	SHORT BOLT (ϕ 1/4" x 13mm SR)		29PCS	14	LEVELER (5/16" x 15mm BLK)		3PCS
5	HANGER BOLTS		5PCS	15	GLUE		1PC
6	SMALL BOLT (ϕ 5/32" x 12mm)		2PCS	16	BOTTOM CAP (ϕ 25mm BLK)		5PCS
7	LONG SCREW (ϕ 4 x 38mm)		16PCS	17	ROUND CAP (ϕ 25mm BLK)		3PCS
8	SMALL SCREW (ϕ 4 x 12mm)		24PCS	18	WASHER (ϕ 1/4" SR)		5PCS
9	SLIDE RAIL SCREW (ϕ 3.5mm x 12mm)		6PCS	19	ALLEN WRENCH (4mm)		1PC
10	CAM BOLT (38mm)		6PCS	20	HEXAGONAL KEY		1PC

Hardware pack is located in 182235B1

ITEM:182235 ASSEMBLY INSTRUCTIONS



STEP 1 Do not tighten until each step is completed or instructed.

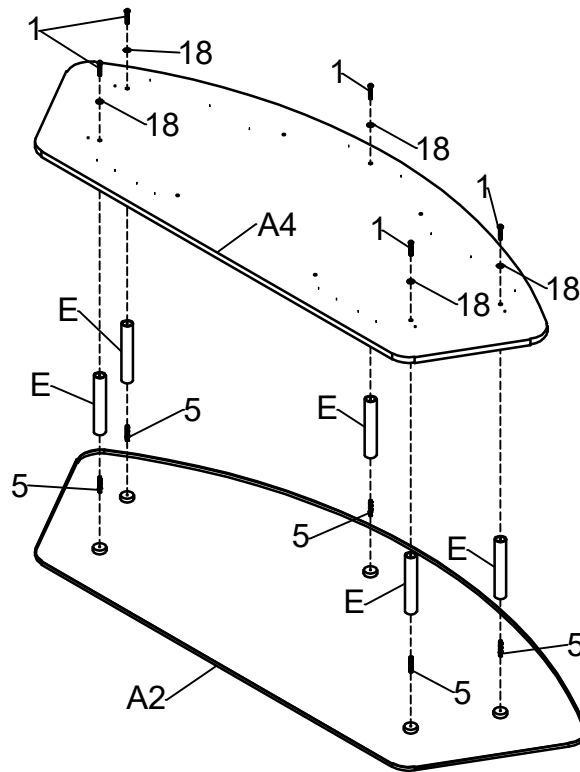

STEP 2

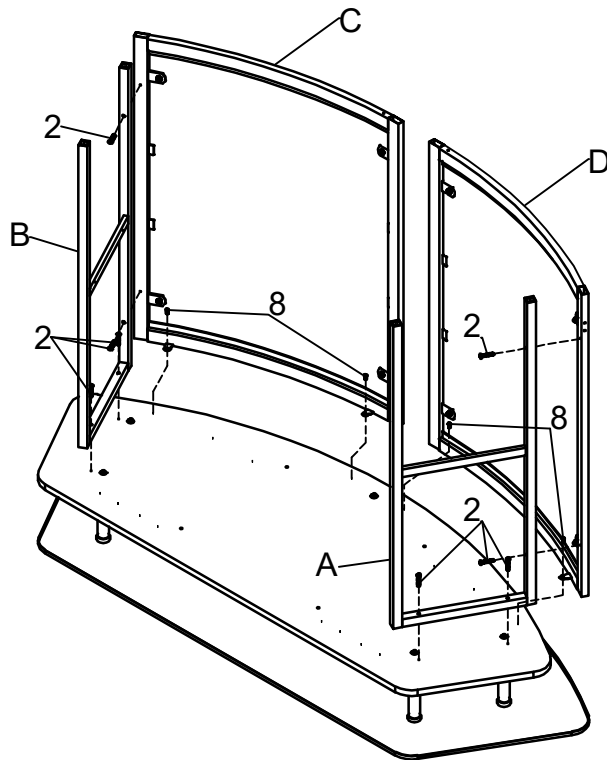

ITEM:182235
ASSEMBLY INSTRUCTIONS
STEP 3

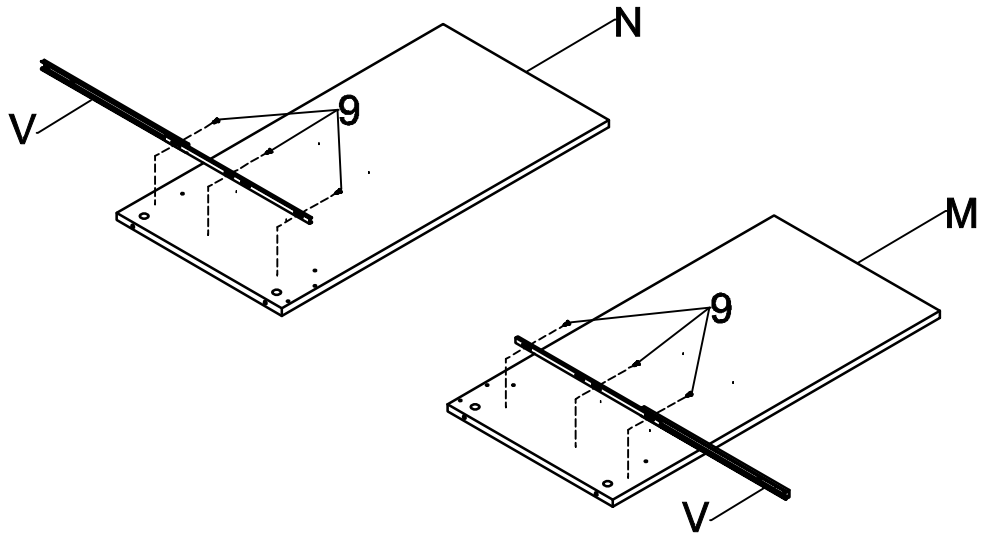

STEP 4

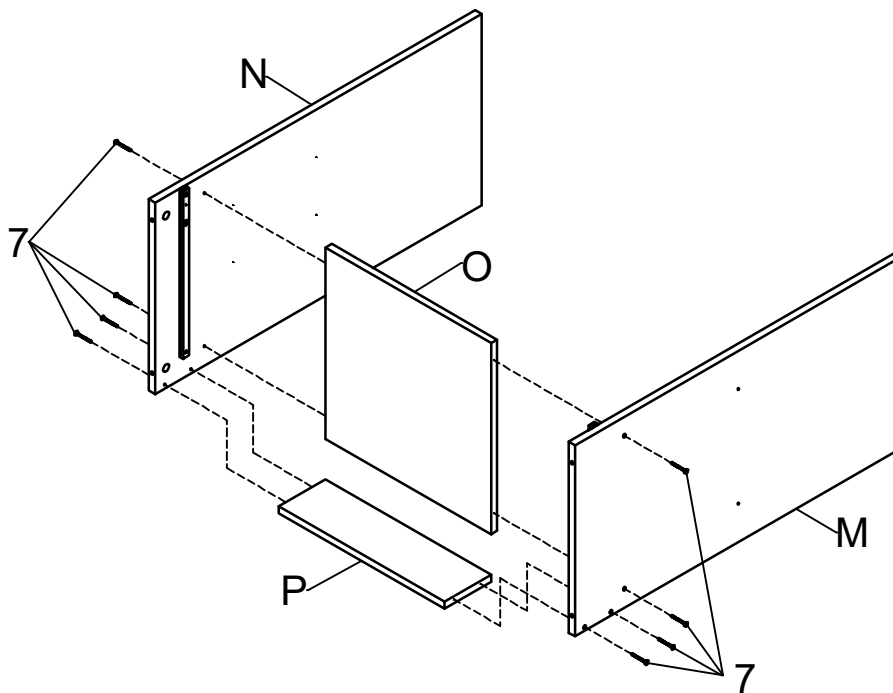

ITEM:182235
ASSEMBLY INSTRUCTIONS
STEP 5

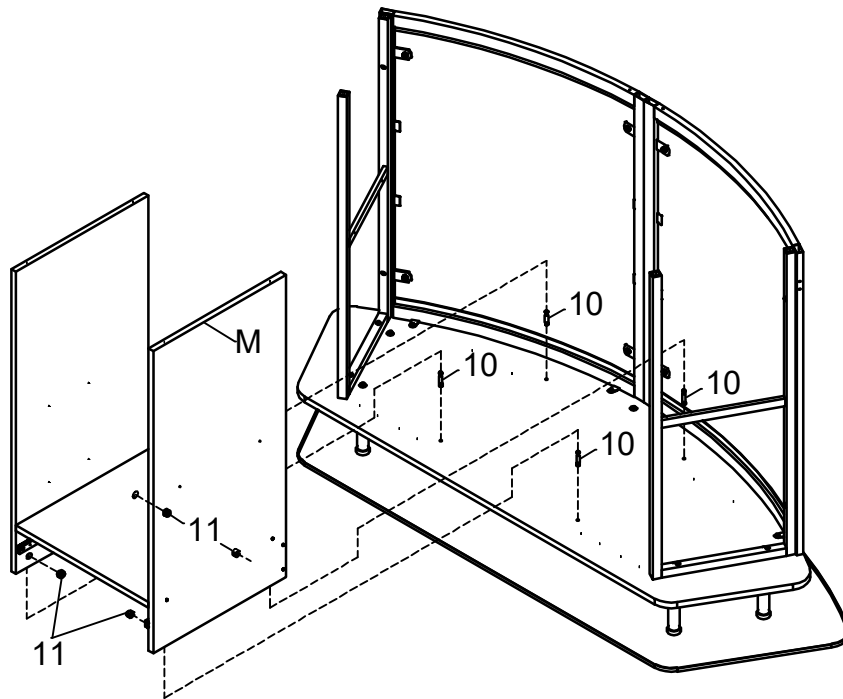

STEP 6

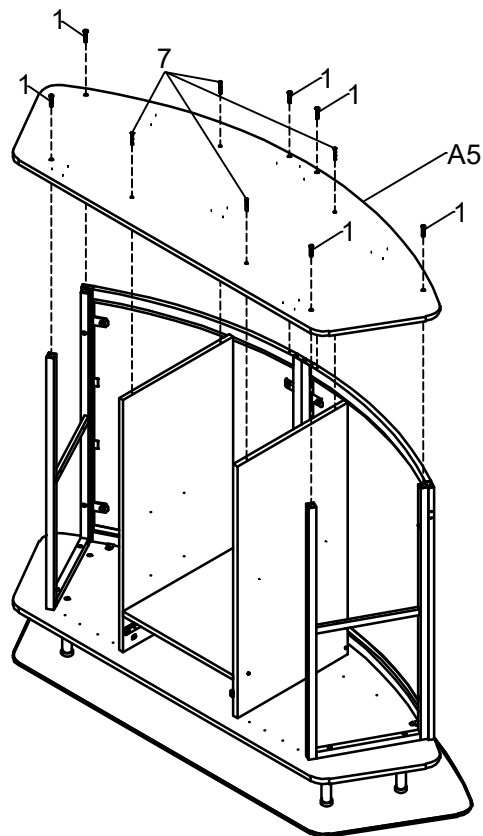

ITEM:182235
ASSEMBLY INSTRUCTIONS
STEP 7

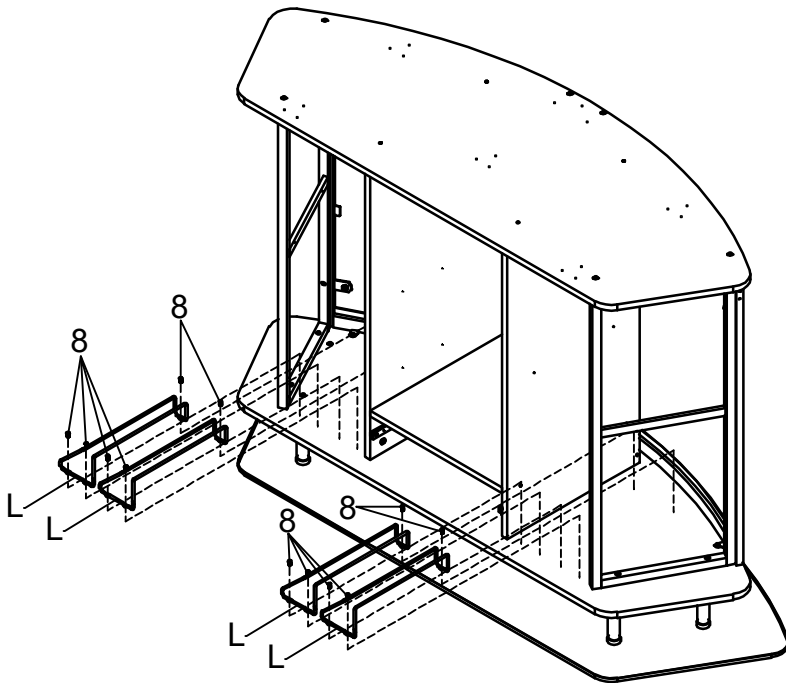

STEP 8

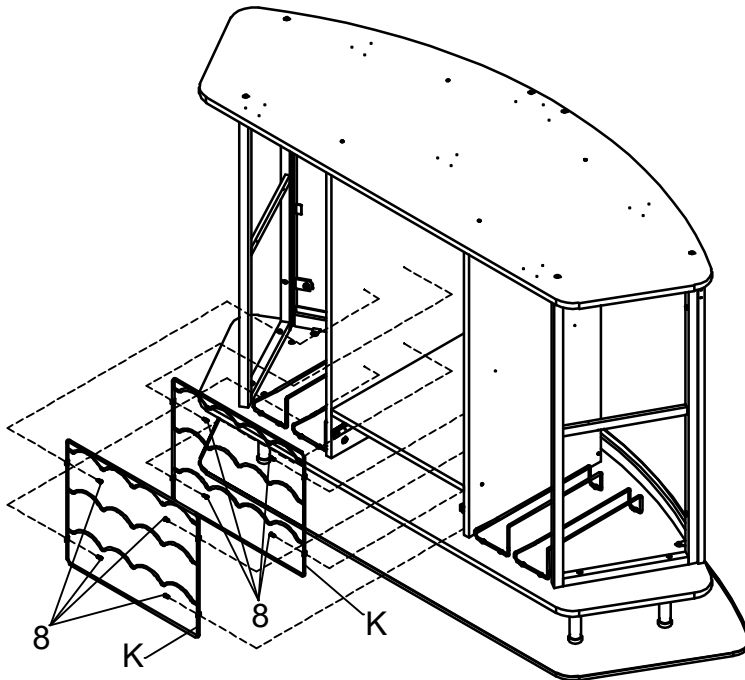

ITEM:182235
ASSEMBLY INSTRUCTIONS
STEP 9

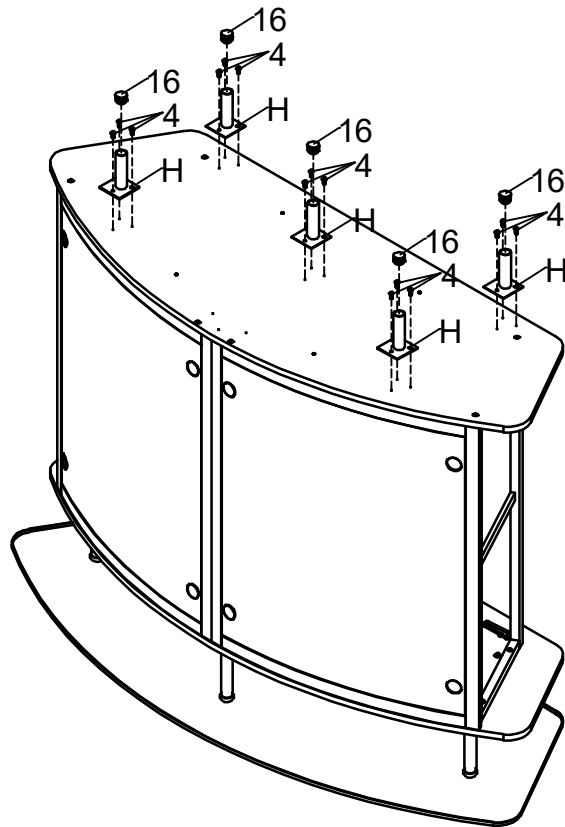

STEP 10

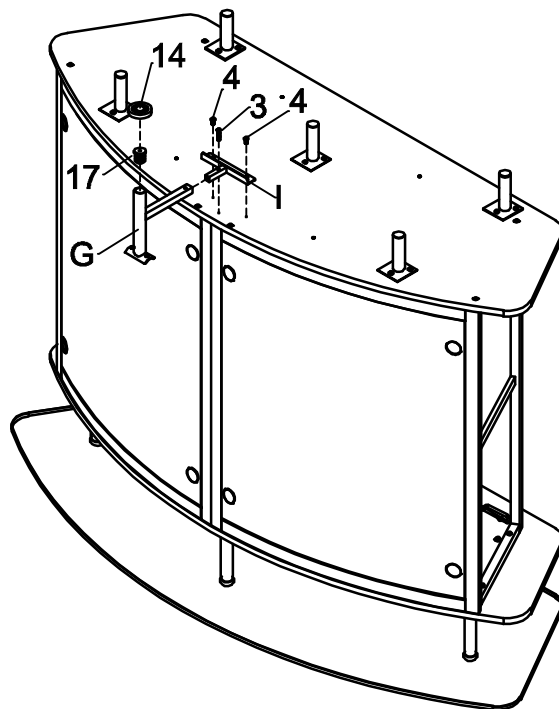

ITEM:182235 ASSEMBLY INSTRUCTIONS



STEP 11

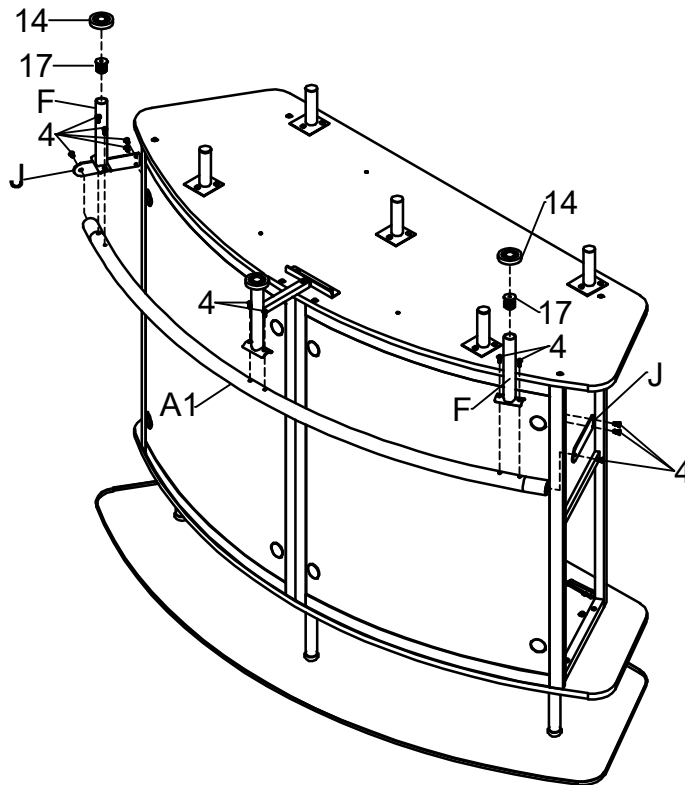

STEP 12

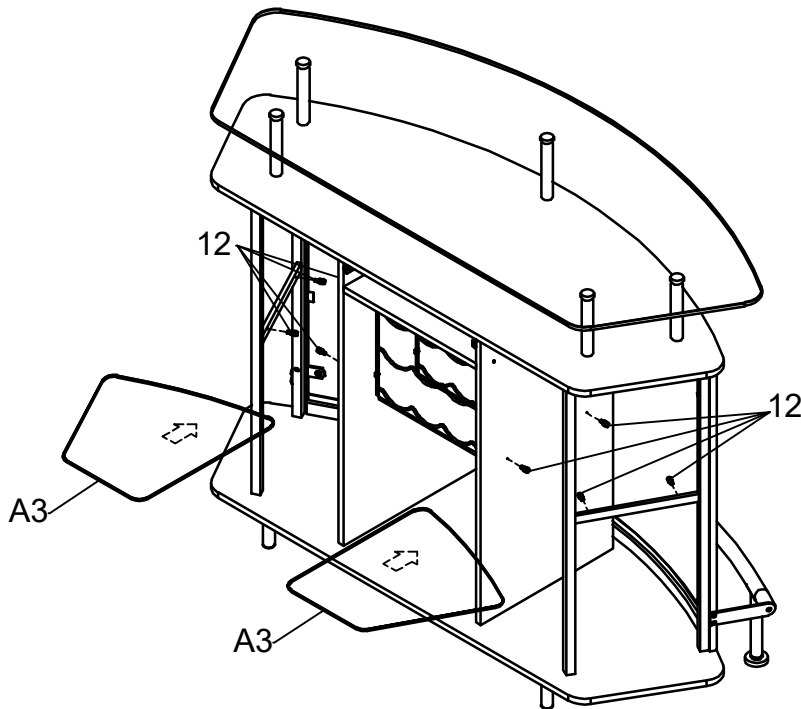

ITEM:182235
ASSEMBLY INSTRUCTIONS
STEP 13

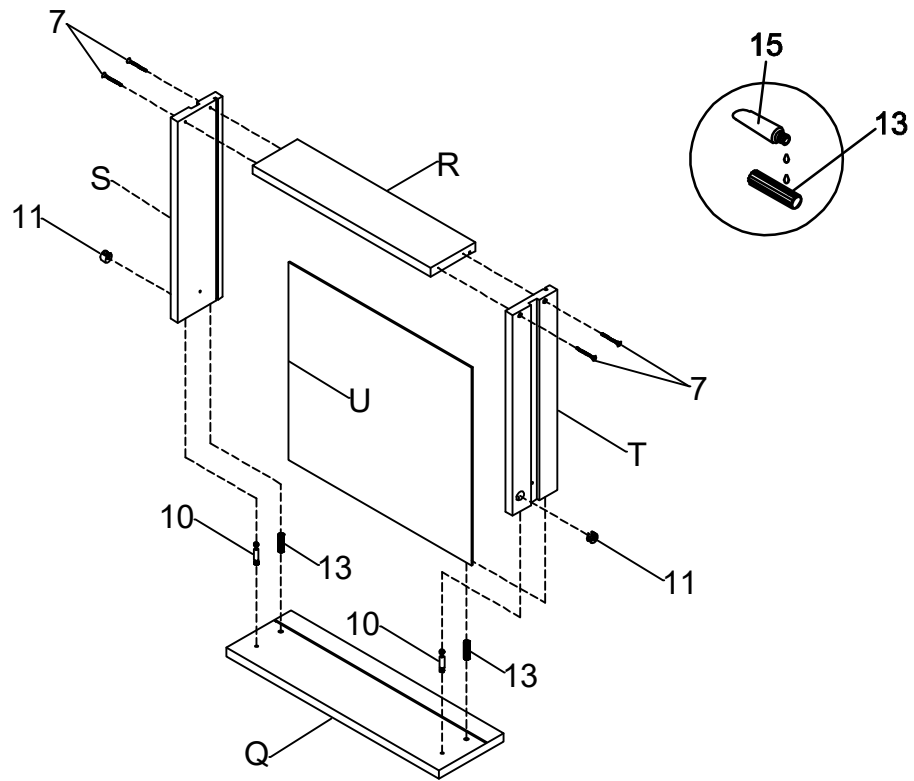

STEP 14
COMPLETE

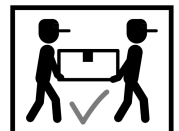
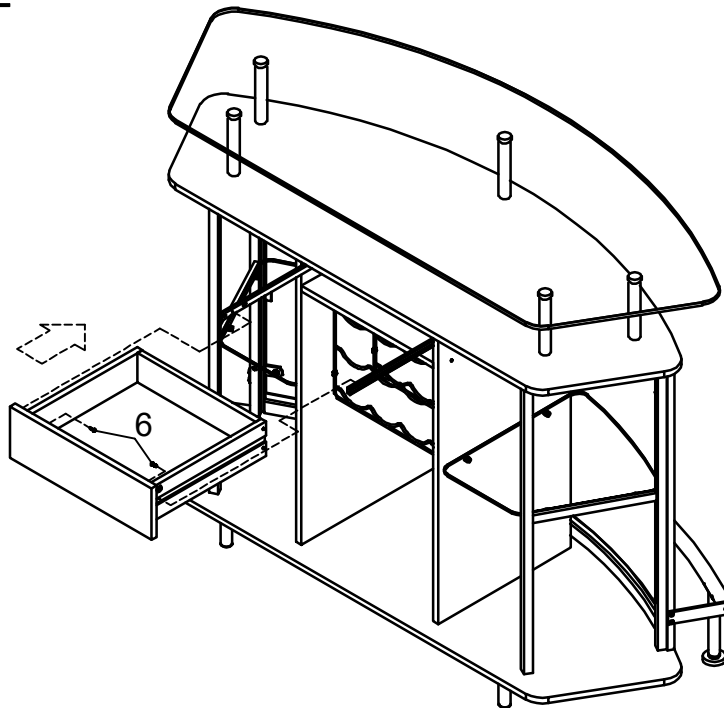

ITEM:182235 ASSEMBLY INSTRUCTIONS



Product Size : 1499 X 600 X 1080 H (MM)
Product Size : 59" X 23.5" X 42.5"

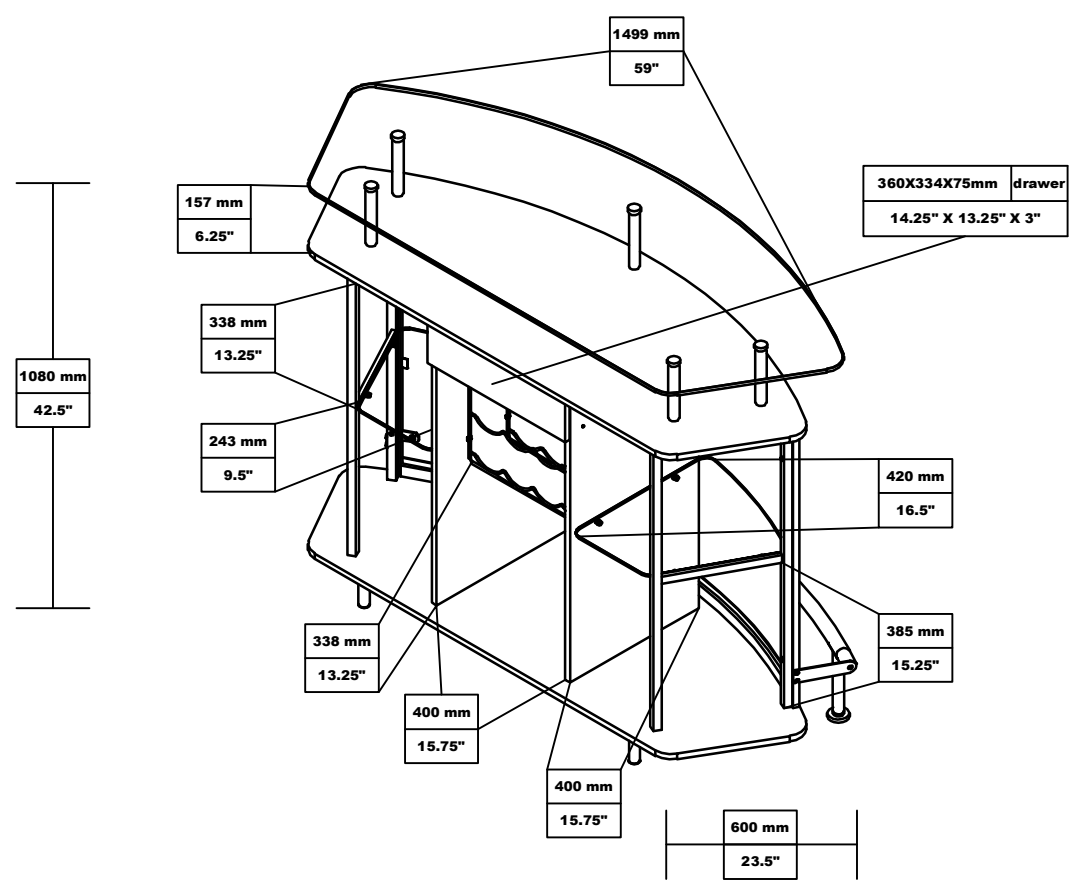

Note : Dimension tolerance $\pm 5\%$