

*ASSEMBLY INSTRUCTIONS  
COASTER FINE FURNITURE*



*Fine Furniture for every stage of life*

**801410**  
***Gaming Desk***

# ITEM:801410



## ASSEMBLY INSTRUCTIONS

### ASSEMBLY TIPS:

1. Remove hardware from box and sort by size.
2. Please check to see that all hardware and parts are present prior to start of assembly.
3. Please follow attached instructions in the same sequence as numbered to assure fast & easy assembly.



### WARNING !



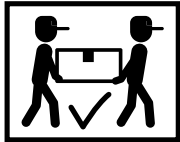

1. Don't attempt to repair or modify parts that are broken or defective. Please contact the store immediately.
2. This product is for home use only and not intended for commercial establishment.

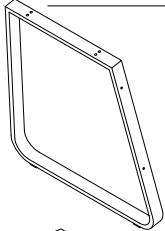
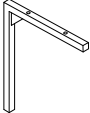
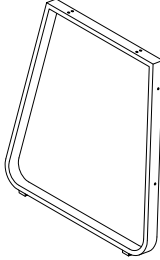
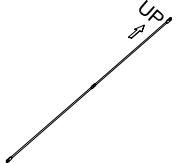
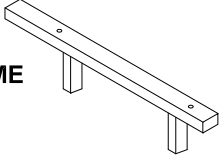
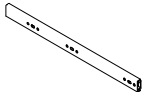
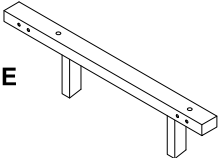
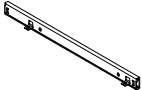
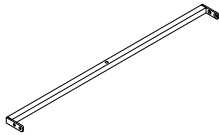

ASSEMBLY TIME

45 MINUTE

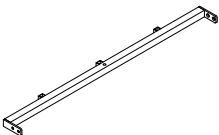



## PARTS IDENTIFICATION

A	LEFT SIDE FRAME		1PC	G	SHELF SUPPORT TUBE		3PCS
B	RIGHT SIDE FRAME		1PC	H	BACK SUPPORT		2PCS
C	LEFT SUPPORT FRAME		1PC	I	LEFT SLIDE		1PC
D	RIGHT SUPPORT FRAME		1PC	J	RIGHT SLIDE		1PC
E	LOWER CROSSBAR		1PC	K	KEYBOARD BRACKET		4PCS
F	UPPER CROSSBAR		1PC	L	SUPPORT BRACKET		2PCS





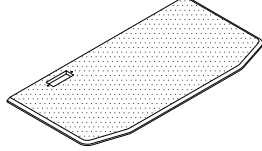

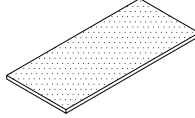
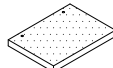
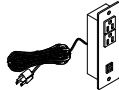





### NOTE:

Phillips head screw driver is required in the assembly process; however, manufacturer does not provide this item.

**PARTS IDENTIFICATION**

M	HOOK		3PCS	Q	TOP SHELF BOARD		1PC
N	STOPPER		2PCS	R	DESK TOP		1PC
O	CUP HOLDER		1PC	S	KEYBOARD		1PC
P	TRAY BOARD		2PCS	T	POWER PORT WITH USB		1PC

**HARDWARE IDENTIFICATION**

1	BOLT (1/4"x1-3/16" - BLK)		10PCS	8	SCREW (M4x13mm - BLK)		2PCS
2	BOLT (1/4"x1/2" - BLK)		8PCS	9	NUT (φ3/16" - BLK)		5PCS
3	BOLT (3/16"x1/2" - BLK)		42PCS	10	WASHER (φ16mm - BLK)		10PCS
4	BOLT (3/16"x1/4" - BLK)		4PCS	11	WASHER (φ12mm - BLK)		57PCS
5	BOLT (5/32"x3/4" - BLK)		4PCS	12	ALLEN WRENCH (4x22x60mm - BLK)		1PC
6	SCREW (M4x25mm - BLK)		6PCS	13	WRENCH		1PC
7	SCREW (M4x15mm -BLK)		4PCS				

**NOTE:**

Phillips head screw driver is required in the assembly process; however, manufacturer does not provide this item.

ITEM:801410

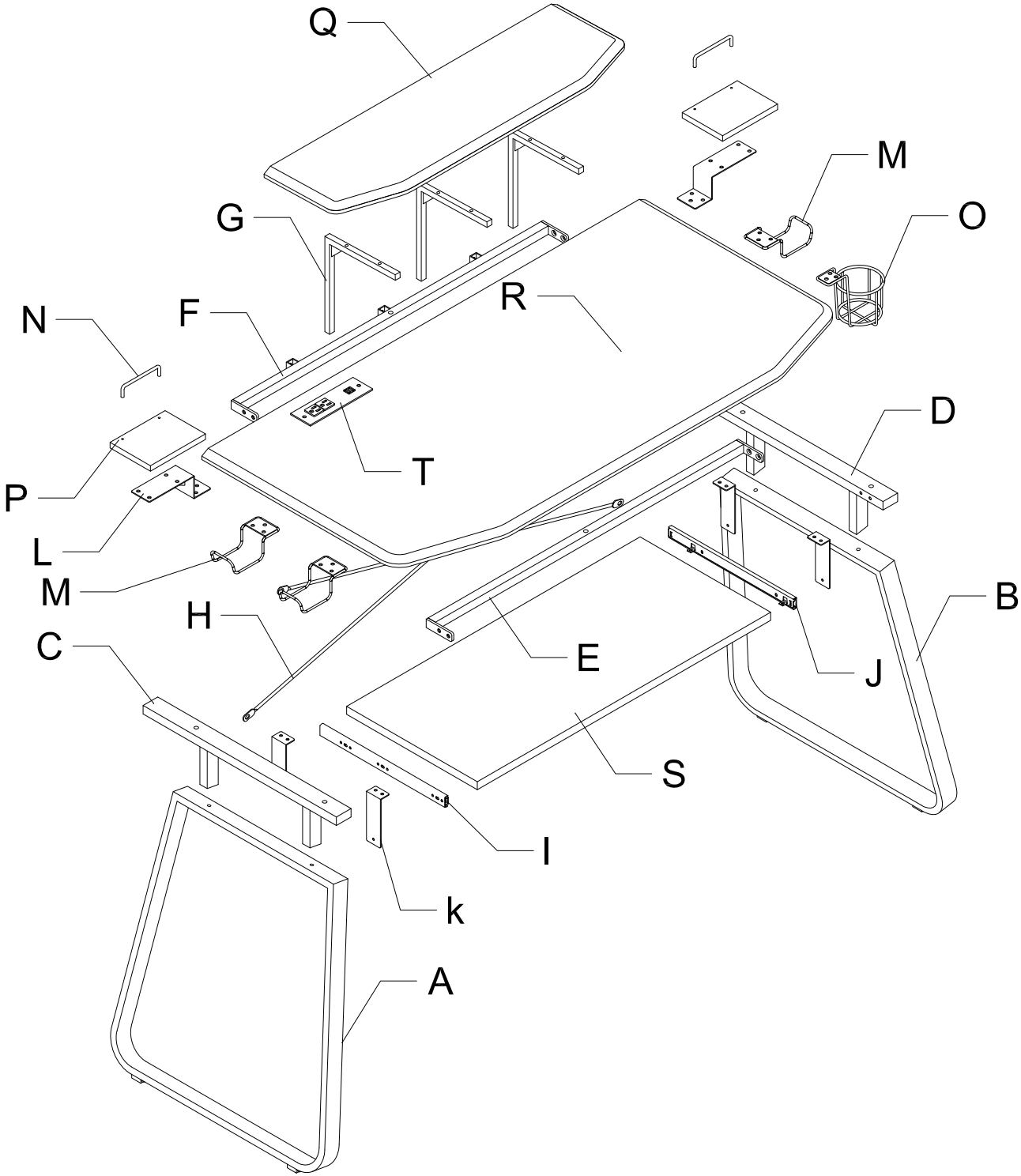



ITEM: **801410**

## ASSEMBLY INSTRUCTIONS

### STEP 1:



#### ASSEMBLY

Do not fully tighten all bolts until assembly is complete.  
This will help all parts to assemble properly.

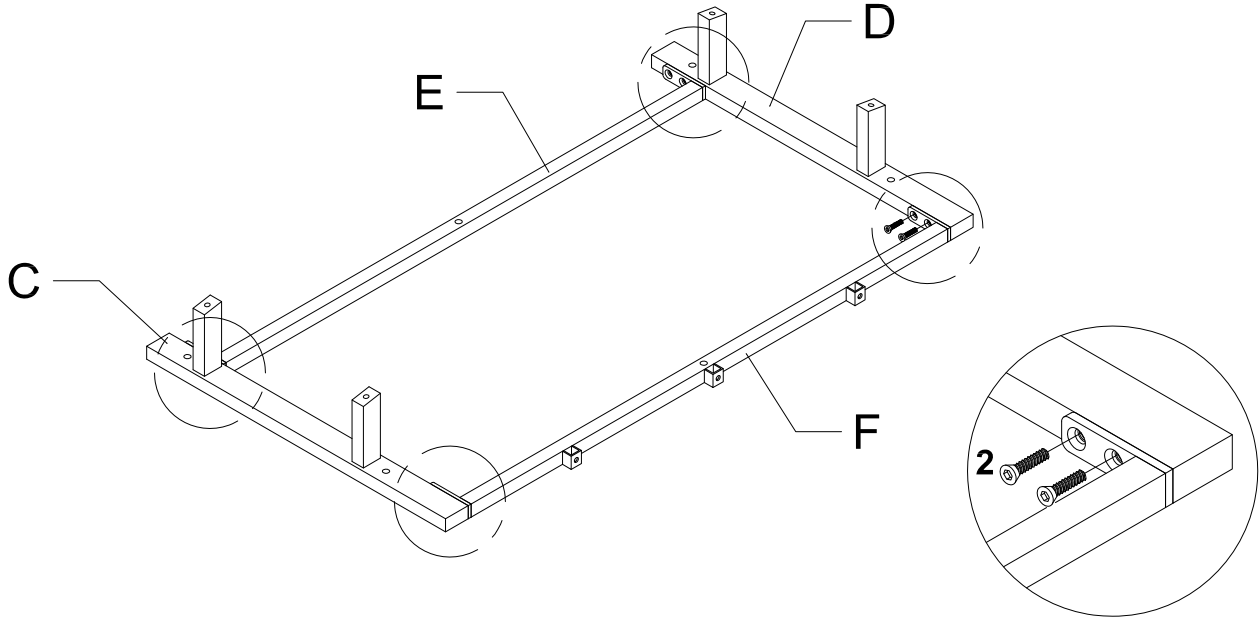
2		8PCS
12		



### STEP 2:

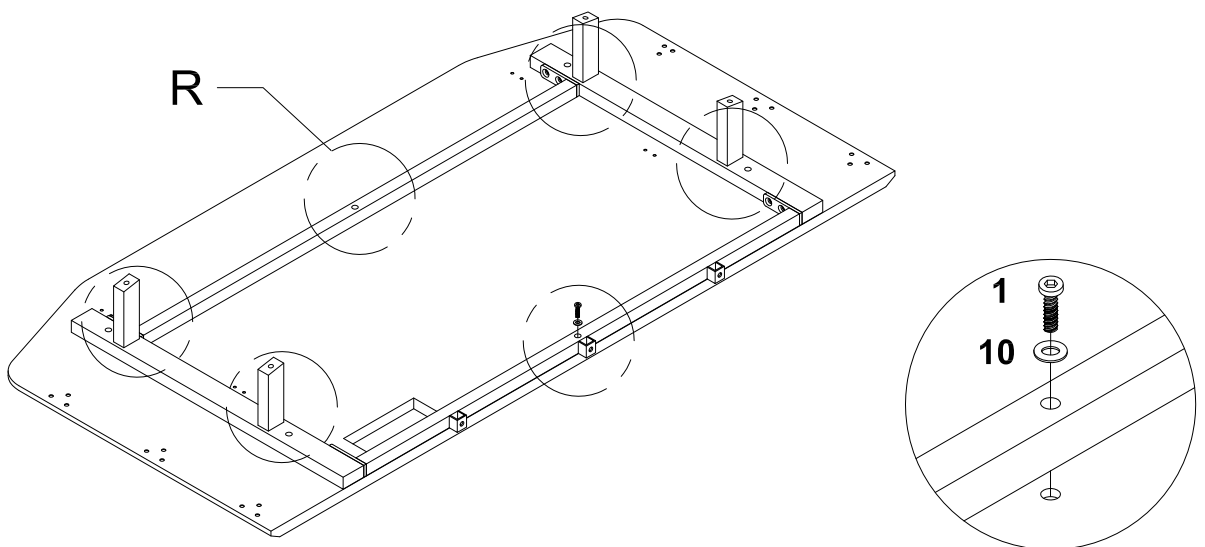

1		6PCS
10		6PCS
12		

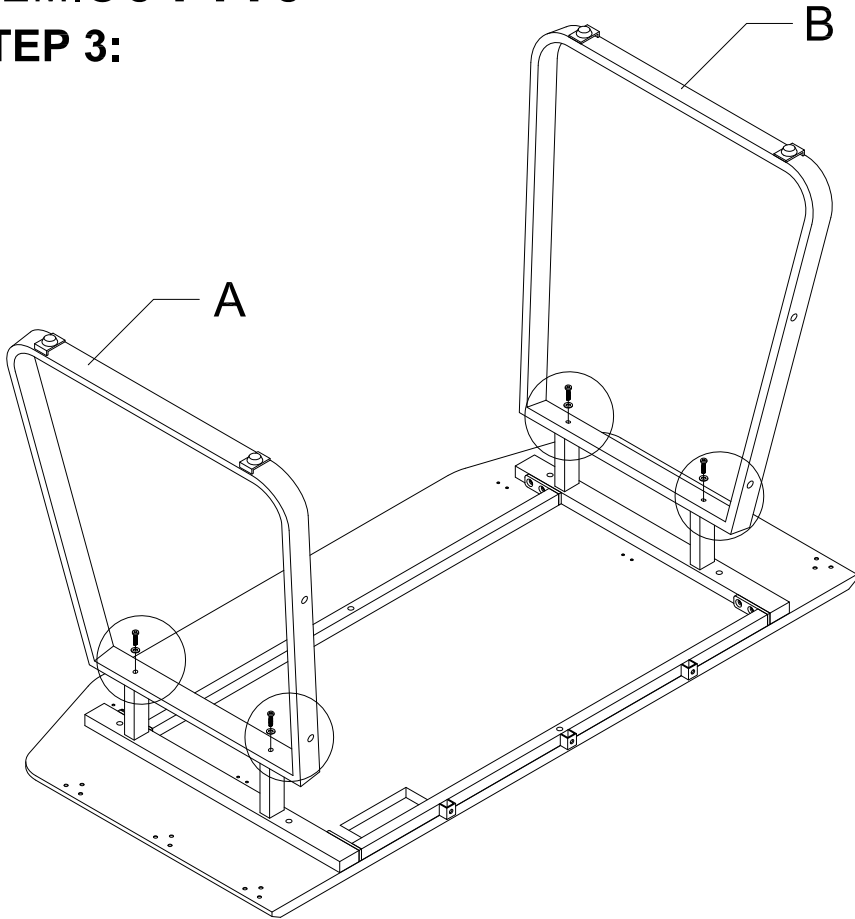

ITEM: **801410**

STEP 3:



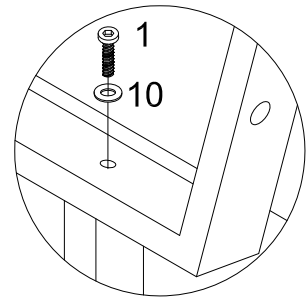

1		4PCS
10		4PCS
12		

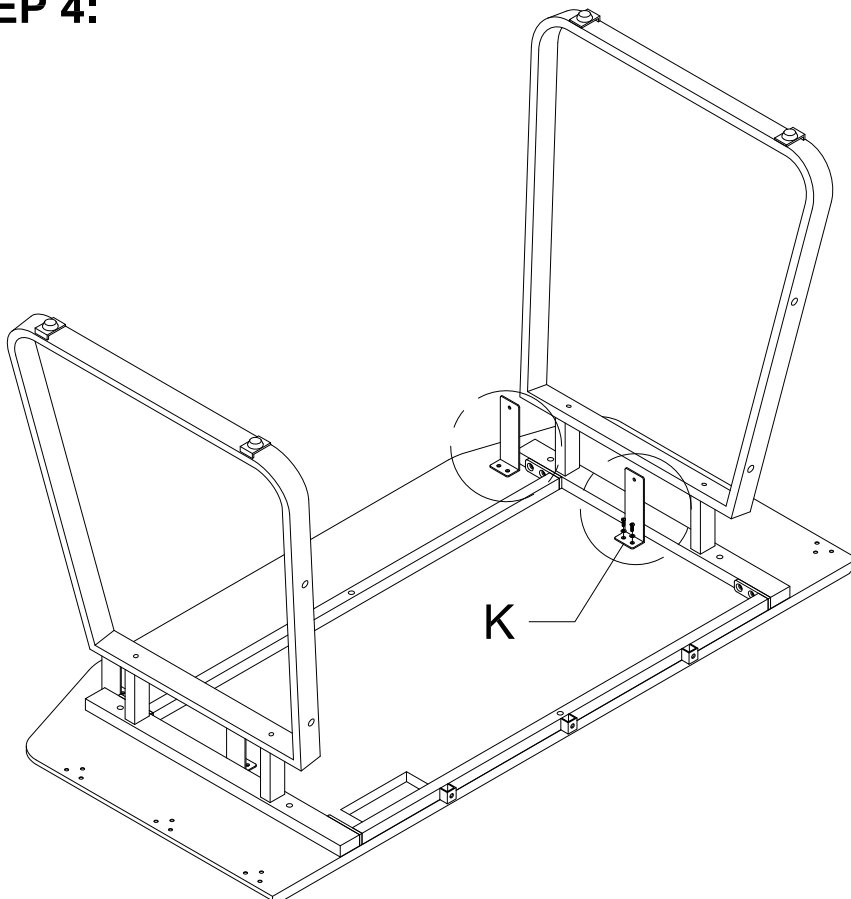

STEP 4:



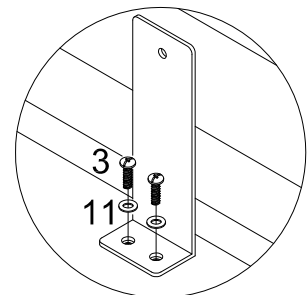

3		8PCS
11		8PCS





ITEM: **801410**

STEP 5:

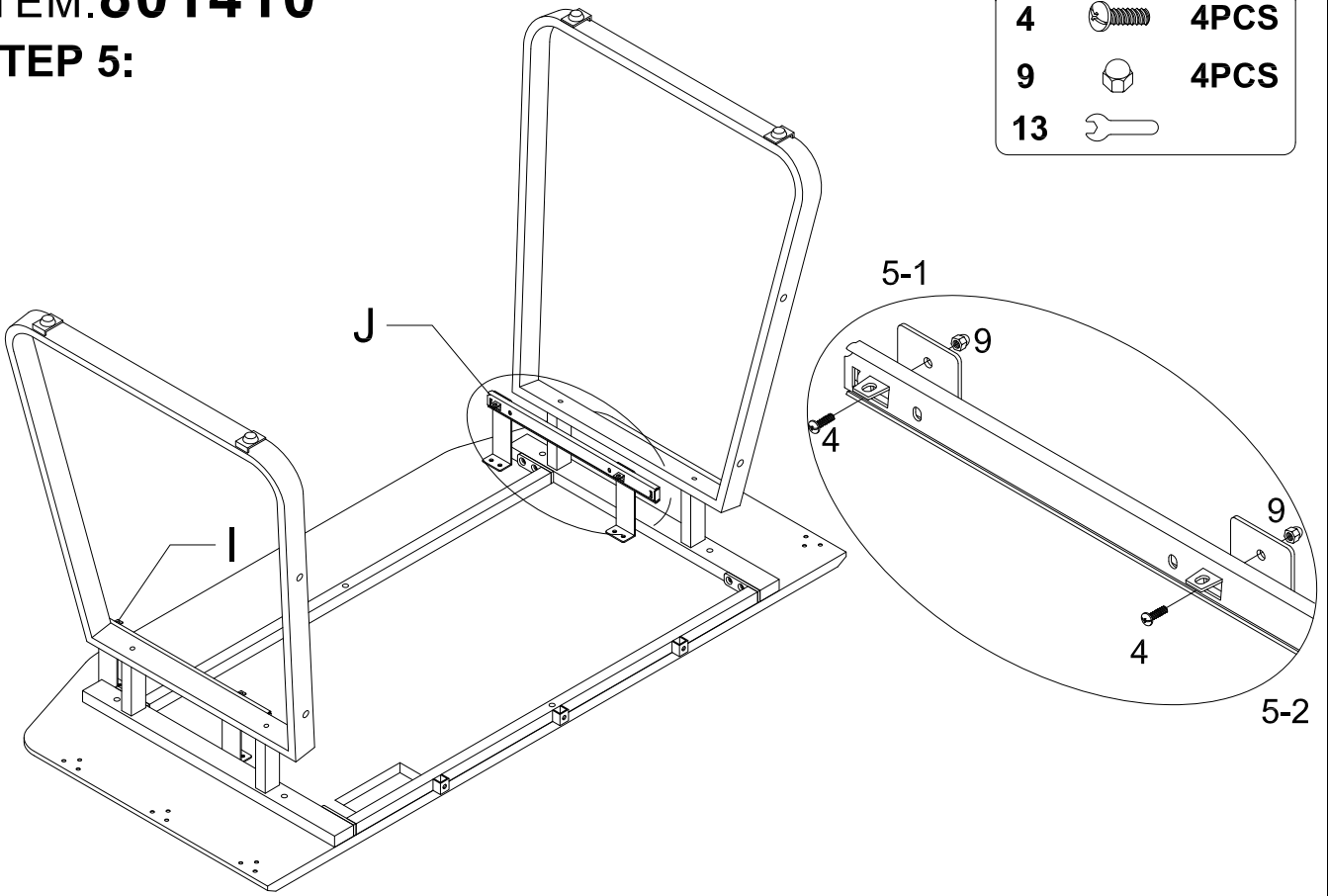
4		4PCS
9		4PCS
13		





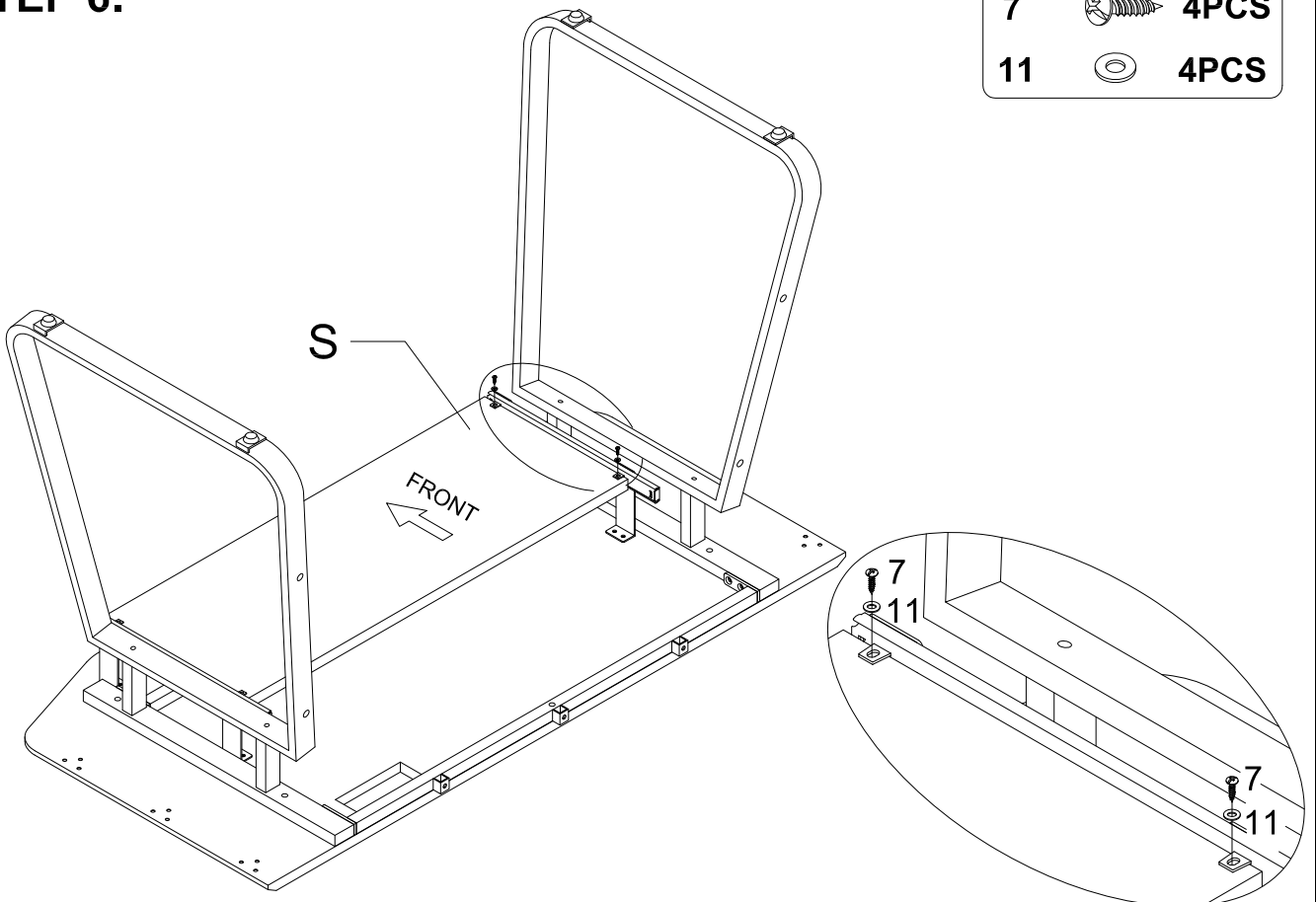

STEP 6:

7		4PCS
11		4PCS





ITEM: **801410**

STEP 7:

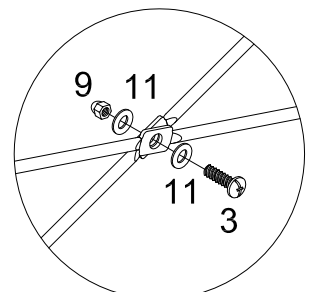
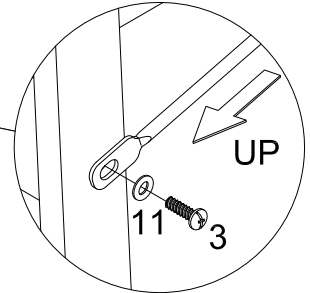
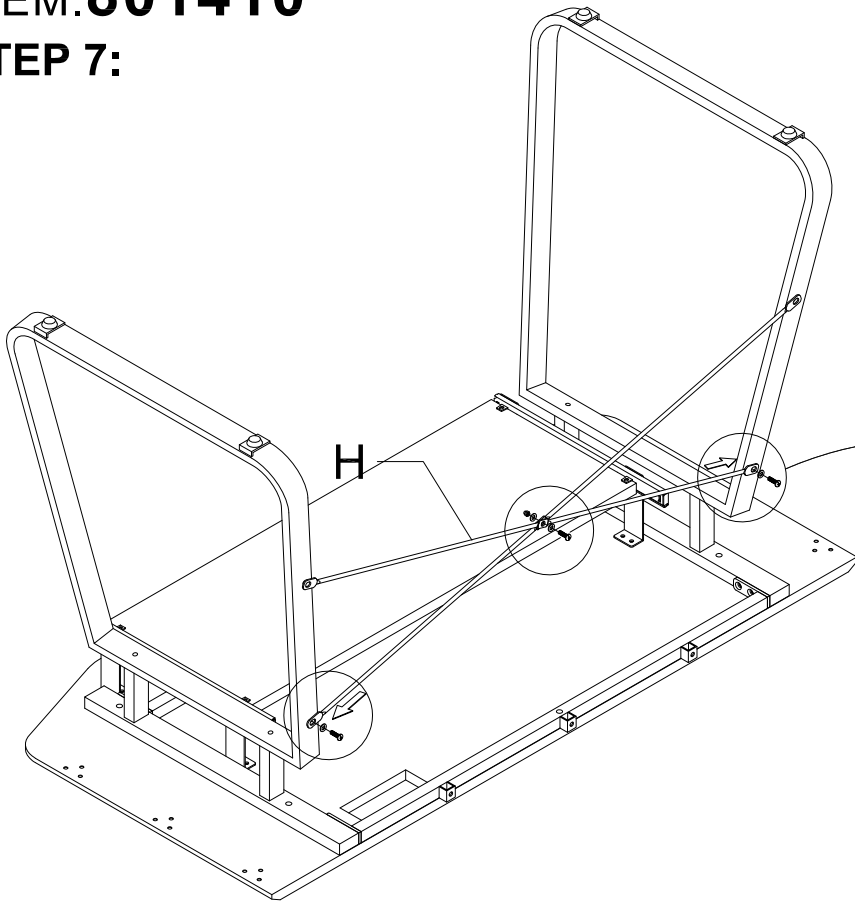
3		5PCS
9		1PC
11		6PCS
13		



STEP 8:

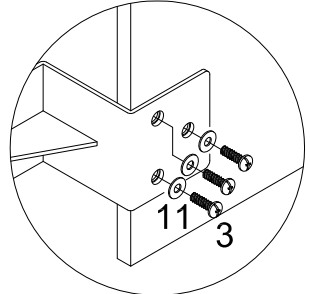
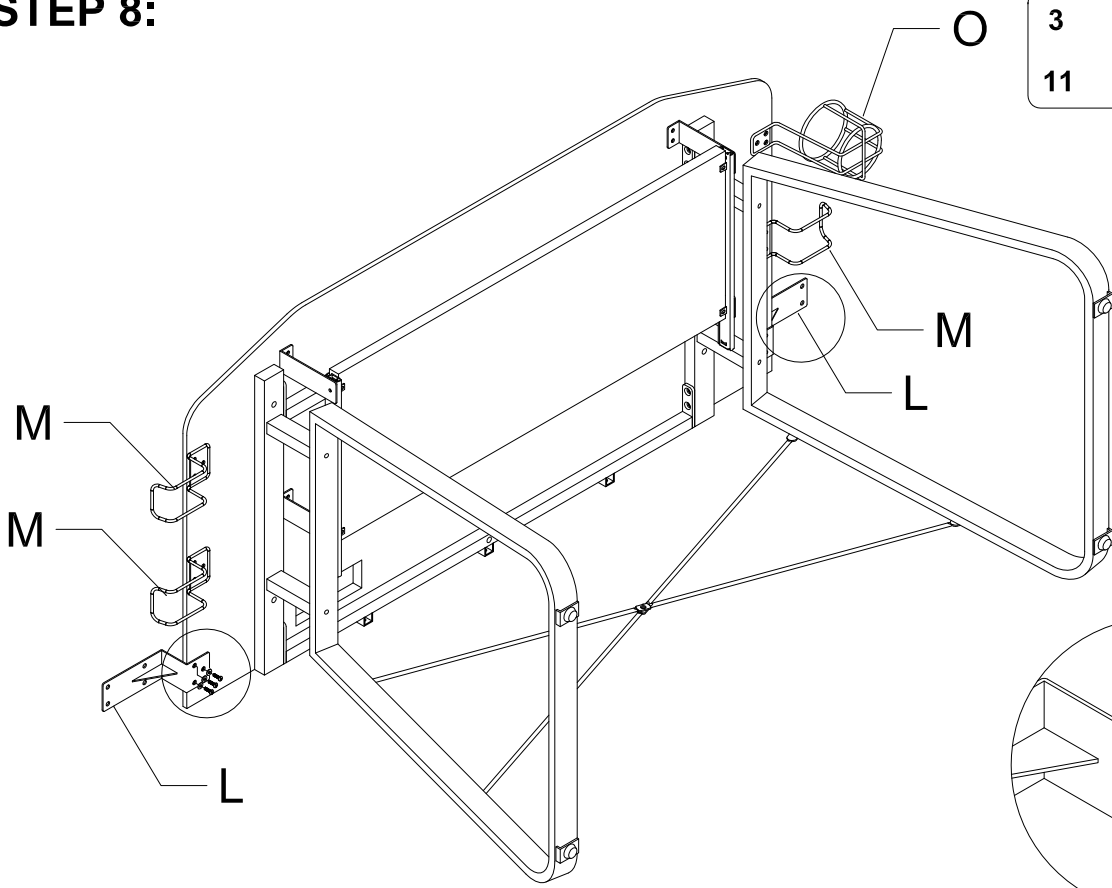

3		18PCS
11		18PCS







ITEM: **801410**

**STEP 9:**

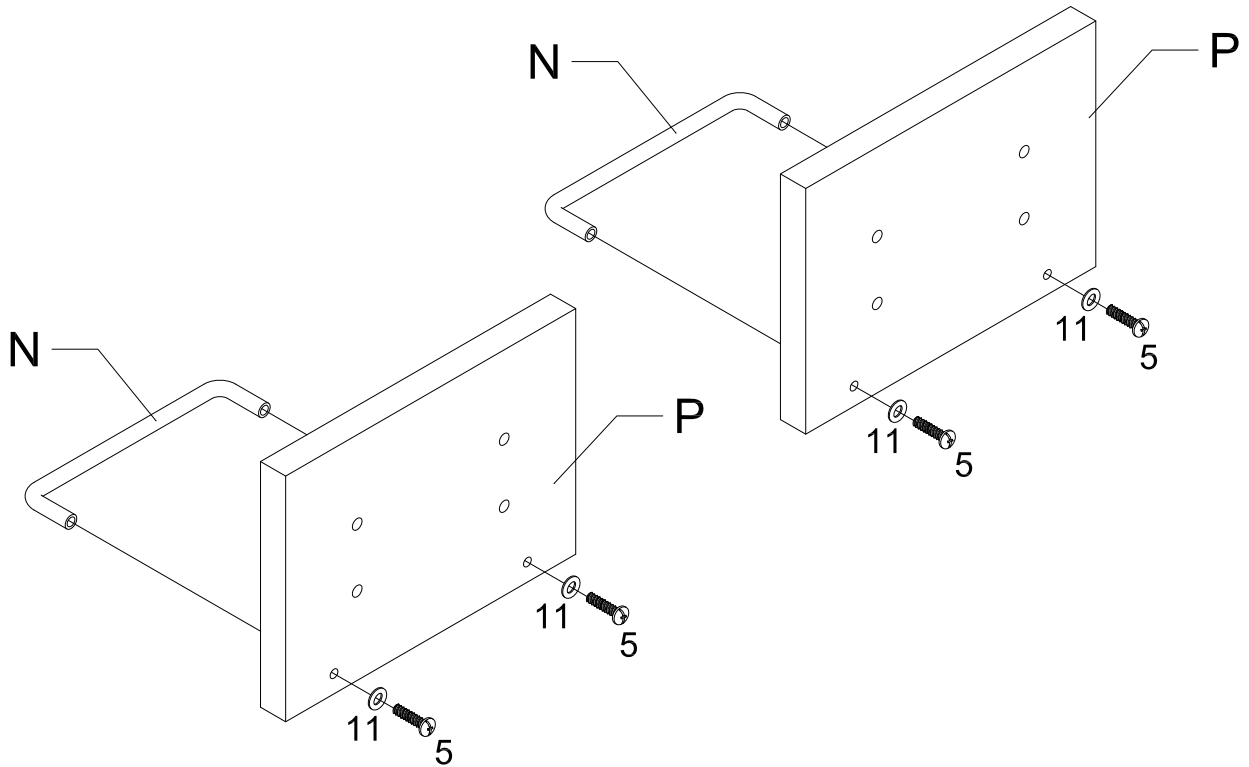
5		4PCS
11		4PCS



**STEP 10:**

3		8PCS
11		8PCS

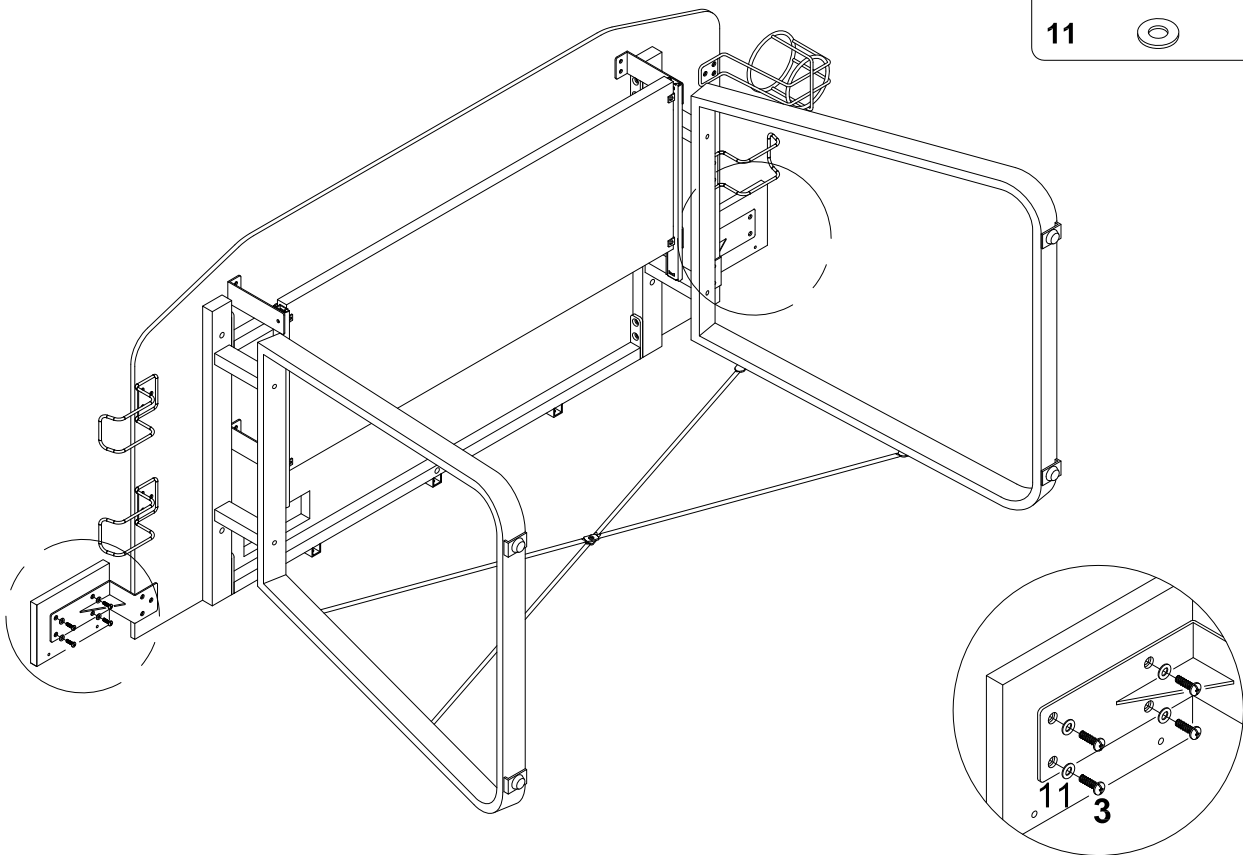

ITEM: **801410**

STEP 11:

8  2PCS

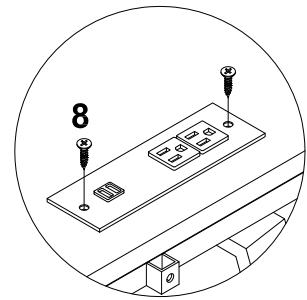
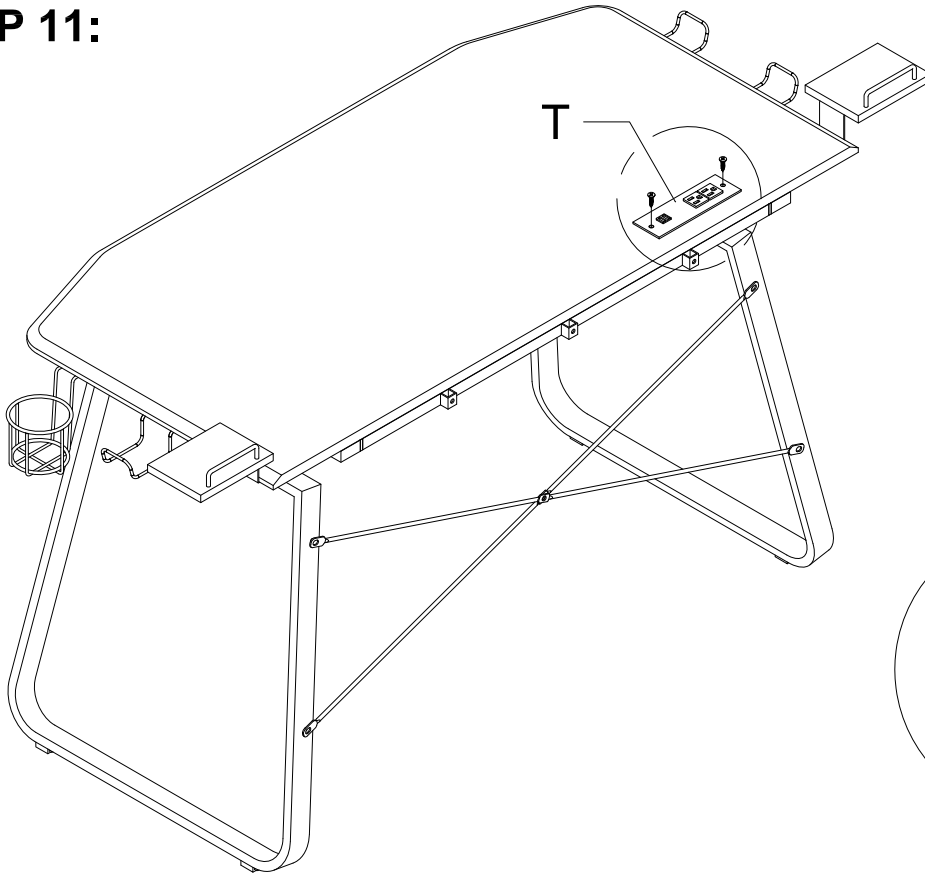

STEP 12:

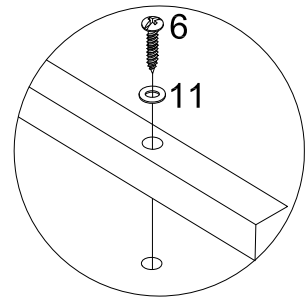
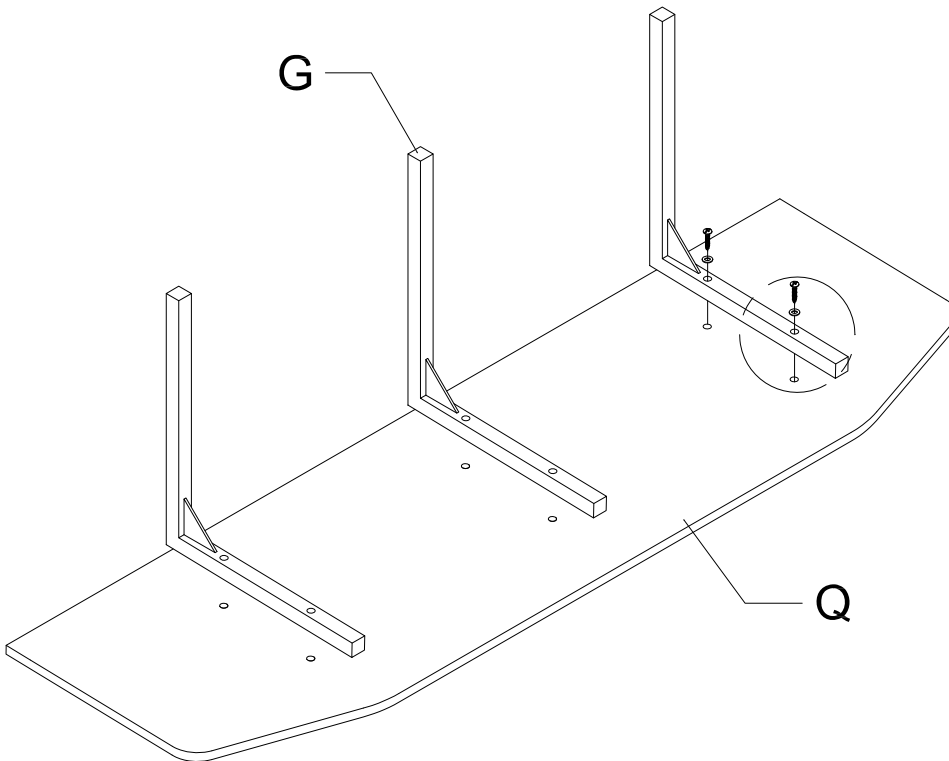

6  6PCS

11  6PCS



ITEM: **801410**

**STEP 13:**

3		3PCS
11		3PCS

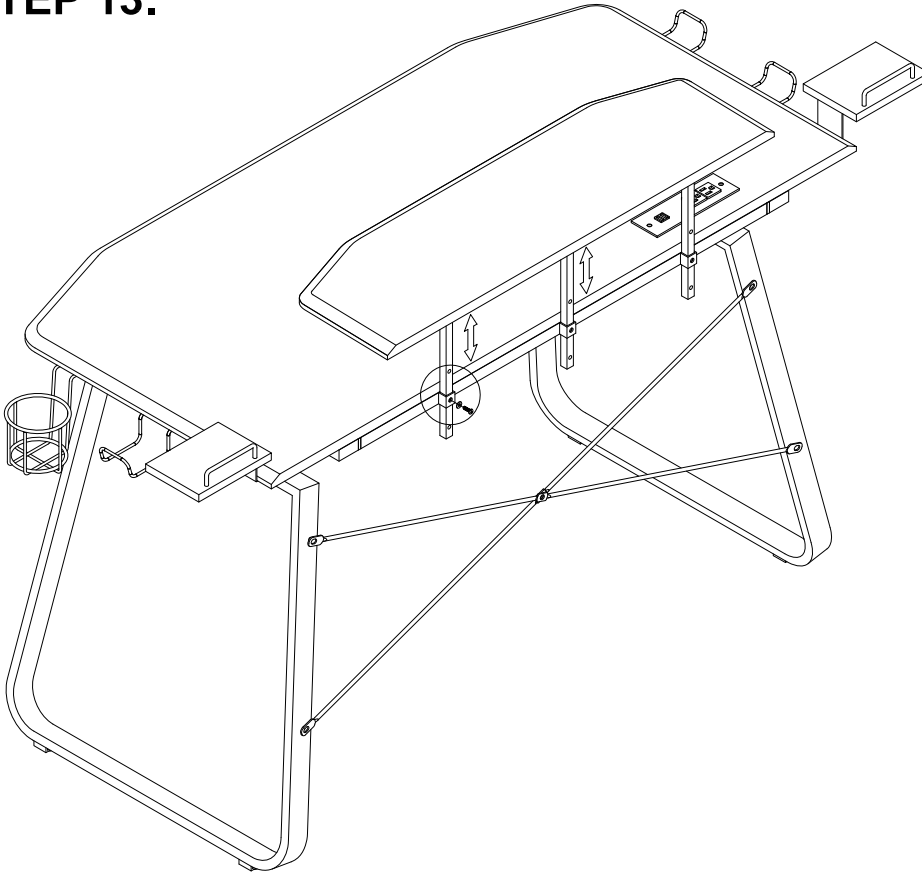

**STEP 14:**

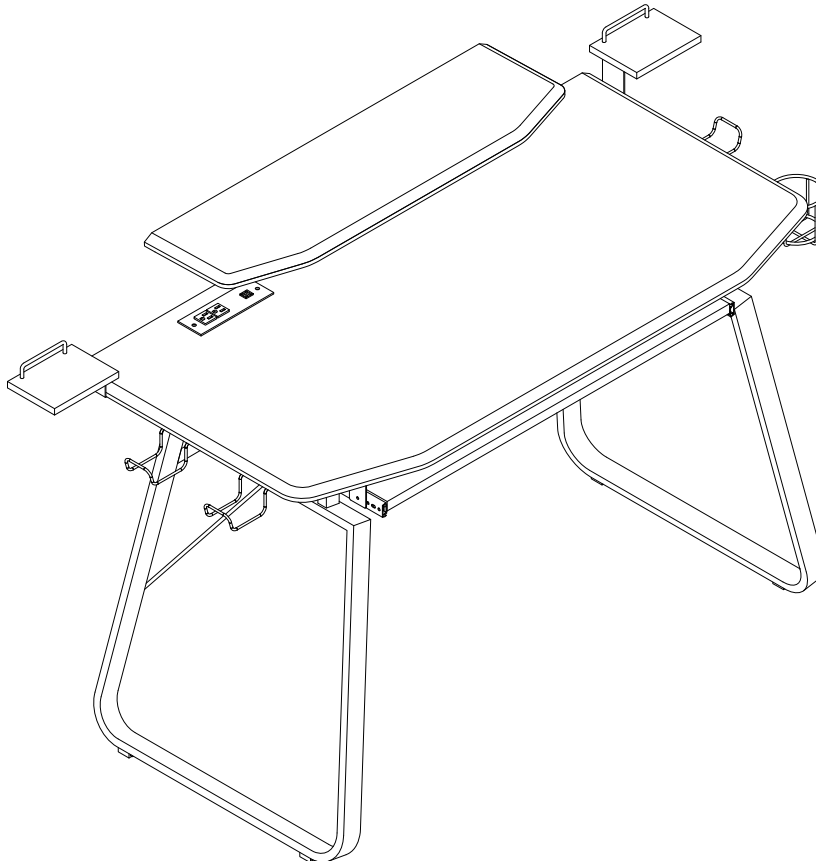

ITEM: **801410**

**COASTER**<sup>®</sup>  
FINE FURNITURE

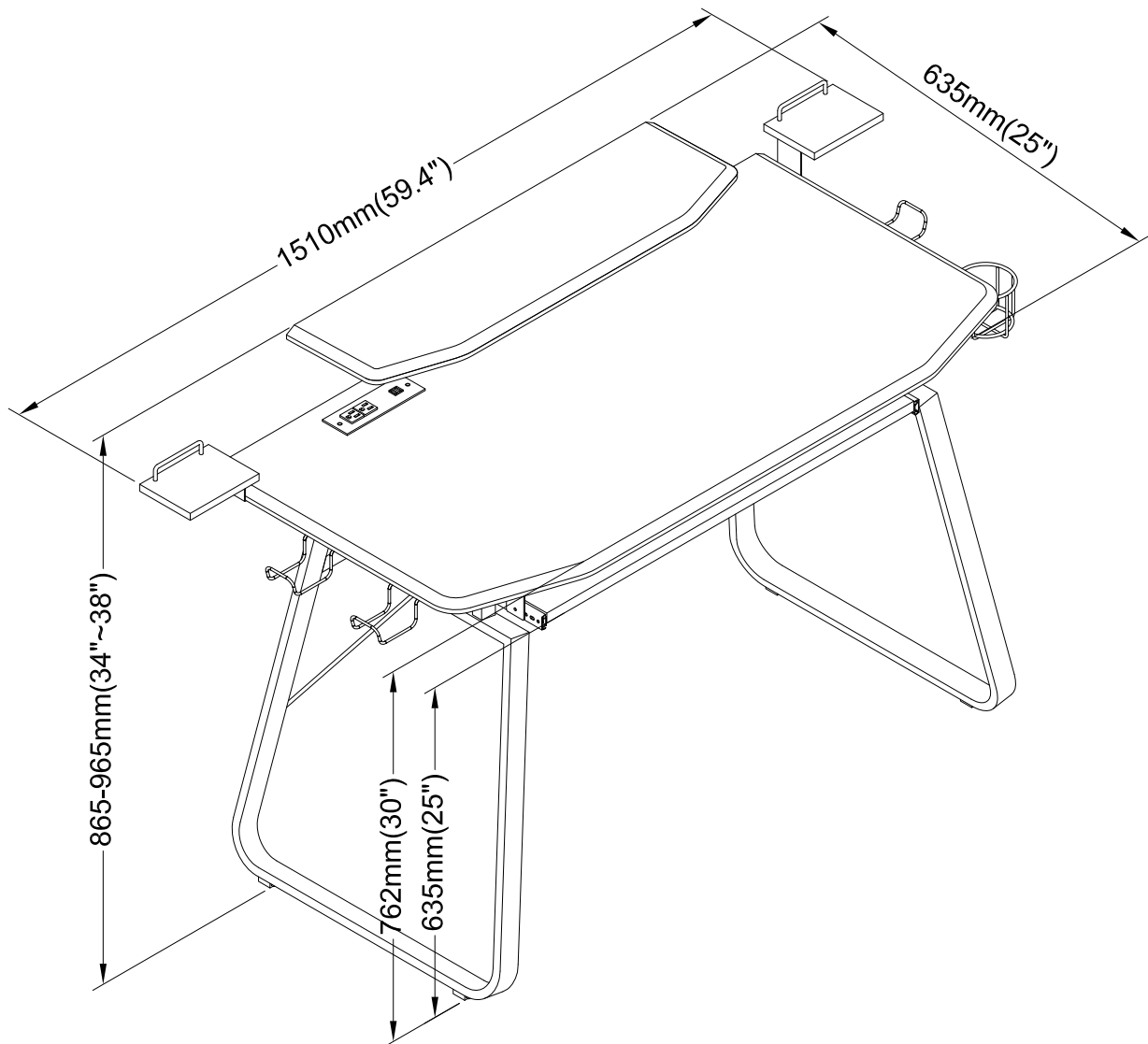

Note : Dimension tolerance  $\pm 5\%$