

*ASSEMBLY INSTRUCTIONS*  
*COASTER FINE FURNITURE*



*Fine Furniture for every stage of life*

**900558**  
***Kitchen Cart***

ITEM: **900558**



## ASSEMBLY INSTRUCTIONS

### ASSEMBLY TIPS:

1. Remove hardware from box and sort by size.
2. Please check to see that all hardware and parts are present prior to start of assembly.
3. Please follow attached instructions in the same sequence as numbered to assure fast & easy assembly.



### WARNING!







1. Don't attempt to repair or modify parts that are broken or defective. Please contact the store immediately.
2. This product is for home use only and not intended for commercial establishments.

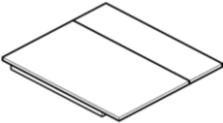
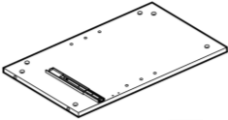

**ASSEMBLY TIME**

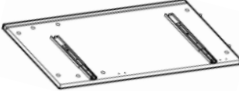
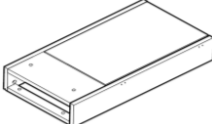
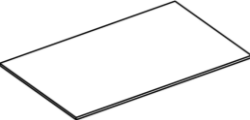
**75 MINUTES**

## PARTS IDENTIFICATION

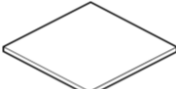
A	TOP		1PC
B	DIVIDER PANEL		1PC
C	BOTTOM PANEL		1PC
D	SIDE PANEL		1PC
E	SIDE BOX		1PC
F	LARGE BACK PANEL		1PC
G	SMALL BACK PANEL		1PC
H	BACK RAIL		1PC
I	BOTTOM RAIL		1PC
J	SHELF PANEL		2PCS

### NOTE:

Phillips head screw driver is required in the assembly process; however, manufacturer does not provide this item.

ITEM: **900558**



## ASSEMBLY INSTRUCTIONS

### ASSEMBLY TIPS:



1. Remove hardware from box and sort by size.
2. Please check to see that all hardware and parts are present prior to start of assembly.
3. Please follow attached instructions in the same sequence as numbered to assure fast & easy assembly.



### WARNING!

1. Don't attempt to repair or modify parts that are broken or defective. Please contact the store immediately.
2. This product is for home use only and not intended for commercial establishments.

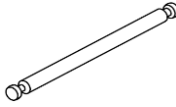
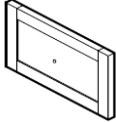
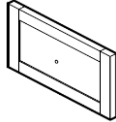
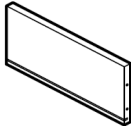
## PARTS IDENTIFICATION

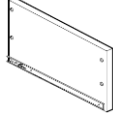
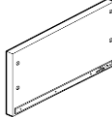
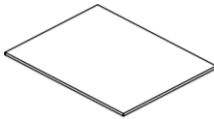
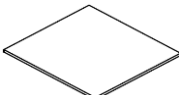
K	ROD HOLDER		2PCS
L	ROD		1PC
M	LEFT DRAWER FRONT PANEL		1PC
N	RIGHT DRAWER FRONT PANEL		1PC
O	LARGE DRAWER BACK PANEL		1PC
P	SMALL DRAWER BACK PANEL		1PC
Q	LEFT DRAWER SIDE PANEL		2PCS
R	RIGHT DRAWER SIDE PANEL		2PCS
S	LARGE DRAWER BOTTOM PANEL		1PC
T	SMALL DRAWER BOTTOM PANEL		1PC

### NOTE:

Phillips head screw driver is required in the assembly process; however, manufacturer does not provide this item.

ITEM: **900558**



## ASSEMBLY INSTRUCTIONS

### ASSEMBLY TIPS:









1. Remove hardware from box and sort by size.
2. Please check to see that all hardware and parts are present prior to start of assembly.
3. Please follow attached instructions in the same sequence as numbered to assure fast & easy assembly.

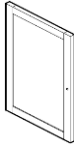
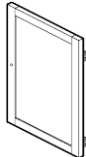

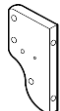
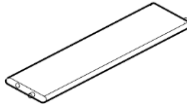
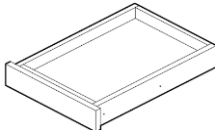
### WARNING!

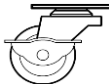
1. Don't attempt to repair or modify parts that are broken or defective. Please contact the store immediately.
2. This product is for home use only and not intended for commercial establishments.

## PARTS IDENTIFICATION

U	LEFT DOOR		1PC
V	RIGHT DOOR		1PC
W	LEFT TRAY SIDE PANEL		1PC
X	RIGHT TRAY SIDE PANEL		1PC
Y	TRAY BOTTOM PANEL		1PC
A2	TRASH CAN HOLDER		1PC
B2	SPINDLE		3PCS
C2	CASTER WITH LOCK		2PCS
D2	CASTER WITHOUT LOCK		2PCS
X1	KNOB WITH SCREW (DRAWER)		2SETS
X2	KNOB WITH SCREW (DOOR)		2SETS

### NOTE:

Phillips head screw driver is required in the assembly process; however, manufacturer does not provide this item.

ITEM: **900558**



## ASSEMBLY INSTRUCTIONS

### ASSEMBLY TIPS:









1. Remove hardware from box and sort by size.
2. Please check to see that all hardware and parts are present prior to start of assembly.
3. Please follow attached instructions in the same sequence as numbered to assure fast & easy assembly.

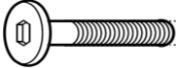
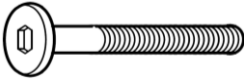

### WARNING!

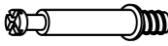
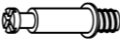
1. Don't attempt to repair or modify parts that are broken or defective. Please contact the store immediately.
2. This product is for home use only and not intended for commercial establishments.

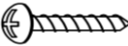
## HARDWARE IDENTIFICATION

1	<b>SHORT BOLT</b> (M6 x 25mm - RBW)		10PCS
2	<b>LONG BOLT</b> (M6 x 50mm - RBW)		4PCS
3	<b>FLAT WASHER</b> (M6 x 13mm - RBW)		8PCS
4	<b>BARREL NUT</b> (M6 x 13mm - RBW)		4PCS
5	<b>ALLEN WRENCH</b> (4mm - BLK)		1PC
6	<b>MAGNETIC CATCH</b>		2PCS
7	<b>LONG CAM BOLT</b> (34mm - RBW)		8PCS
8	<b>SHORT CAM BOLT</b> (24mm - RBW)		2PCS
9	<b>CAM NUT</b> (9mm - RBW)		10PCS
10	<b>SHELF SUPPORT</b>		8PCS
11	<b>PAN HEAD SCREW</b> (#8 x 1 1/4" - RBW)		16PCS
12	<b>SHORT FLAT HEAD SCREW</b> (M3 x 12mm - RBW)		12PCS
13	<b>LONG FLAT HEAD SCREW</b> (M3.5 x 16mm - RBW)		20PCS

### NOTE:

Phillips head screw driver is required in the assembly process; however, manufacturer does not provide this item.

ITEM: **900558**



**ASSEMBLY INSTRUCTIONS**

**STEP 1**

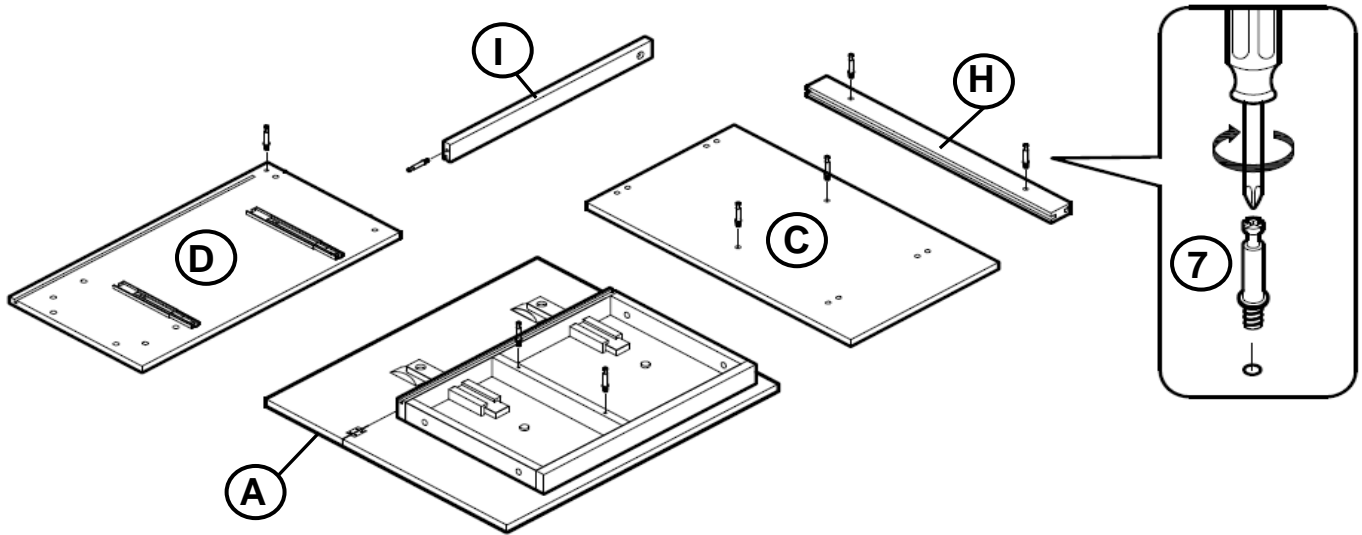

**STEP 2**

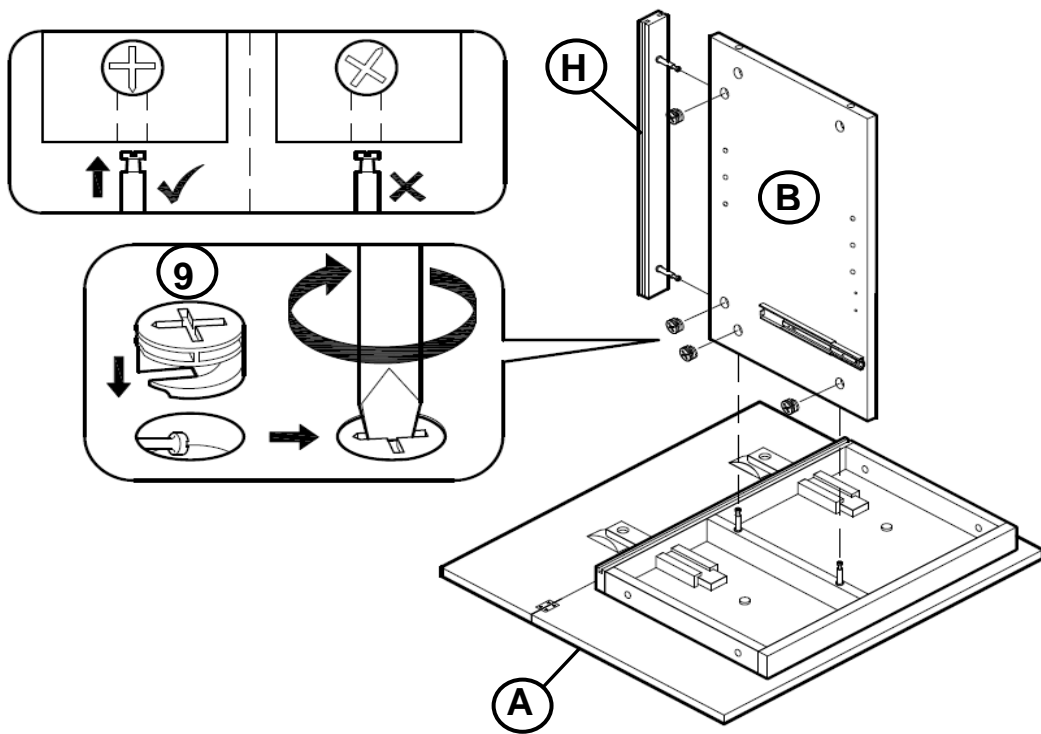

ITEM: 900558



**ASSEMBLY INSTRUCTIONS**  
**STEP 3**

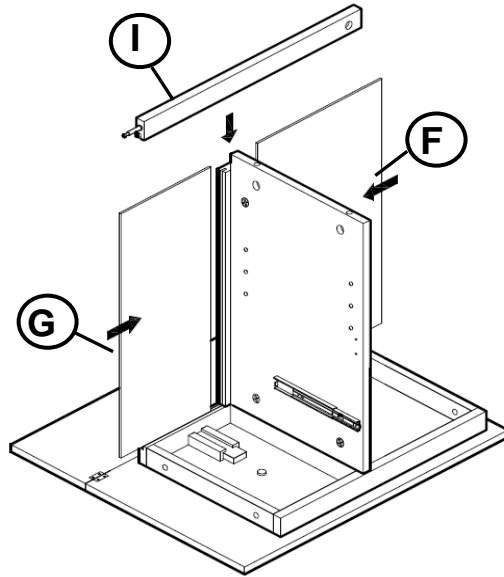

**STEP 4**

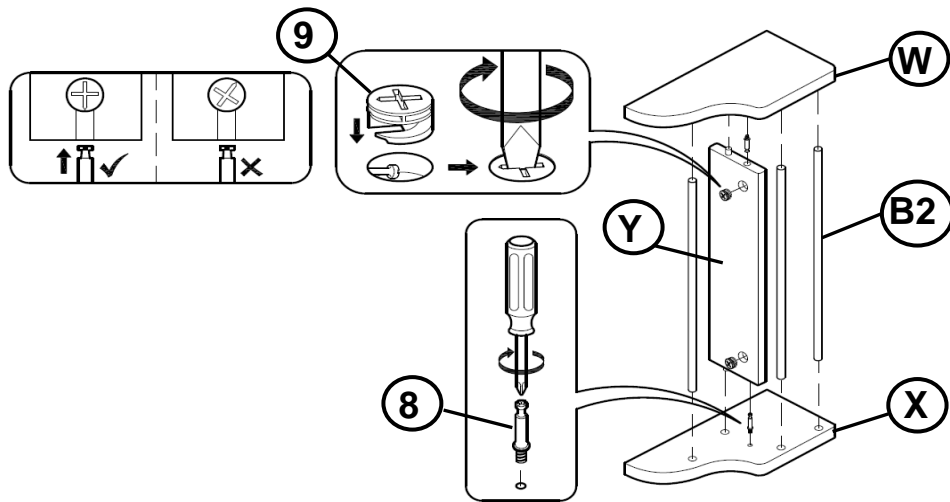

**STEP 5**

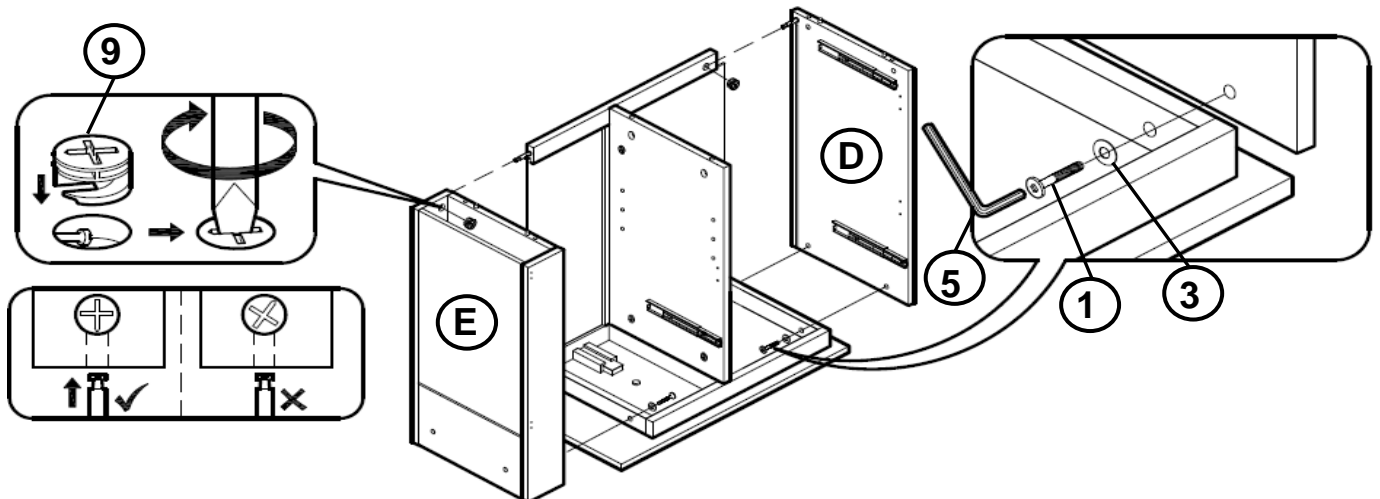

ITEM: **900558**

**ASSEMBLY INSTRUCTIONS**  
**STEP 6**

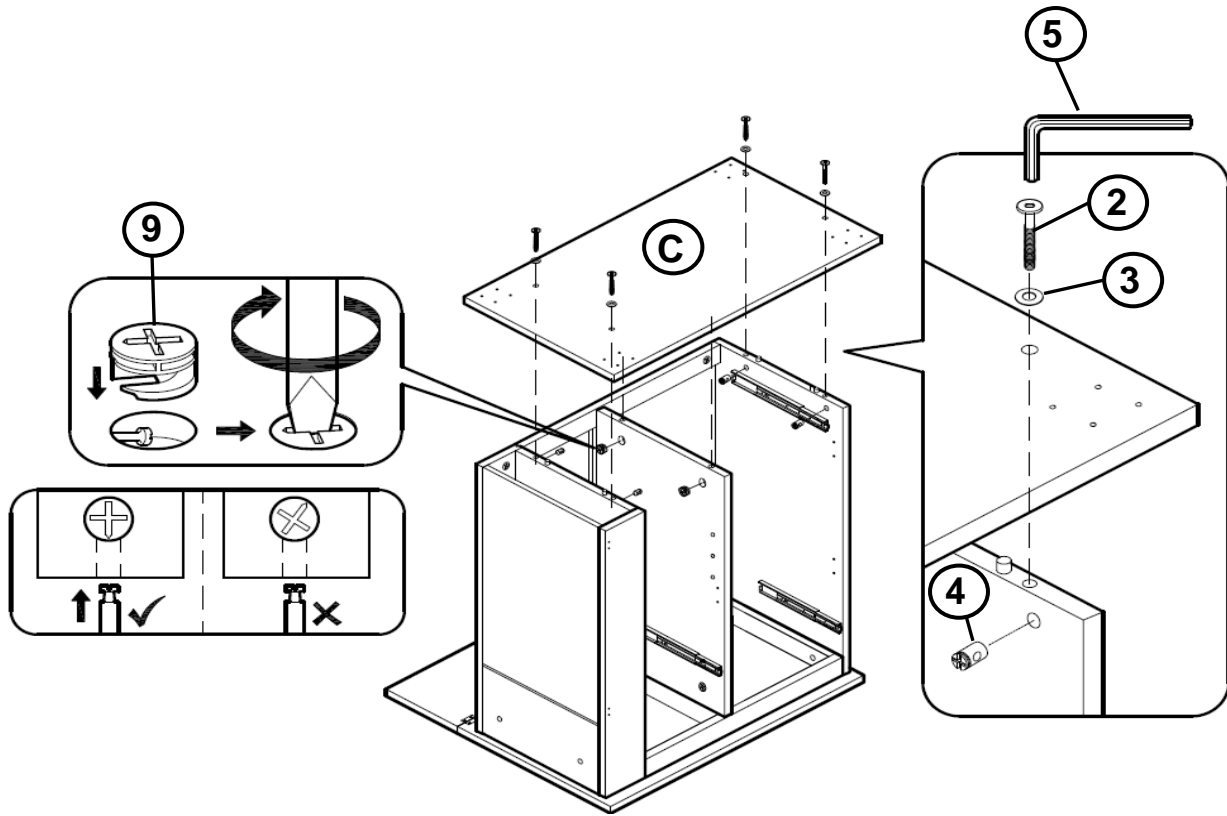

**STEP 7**

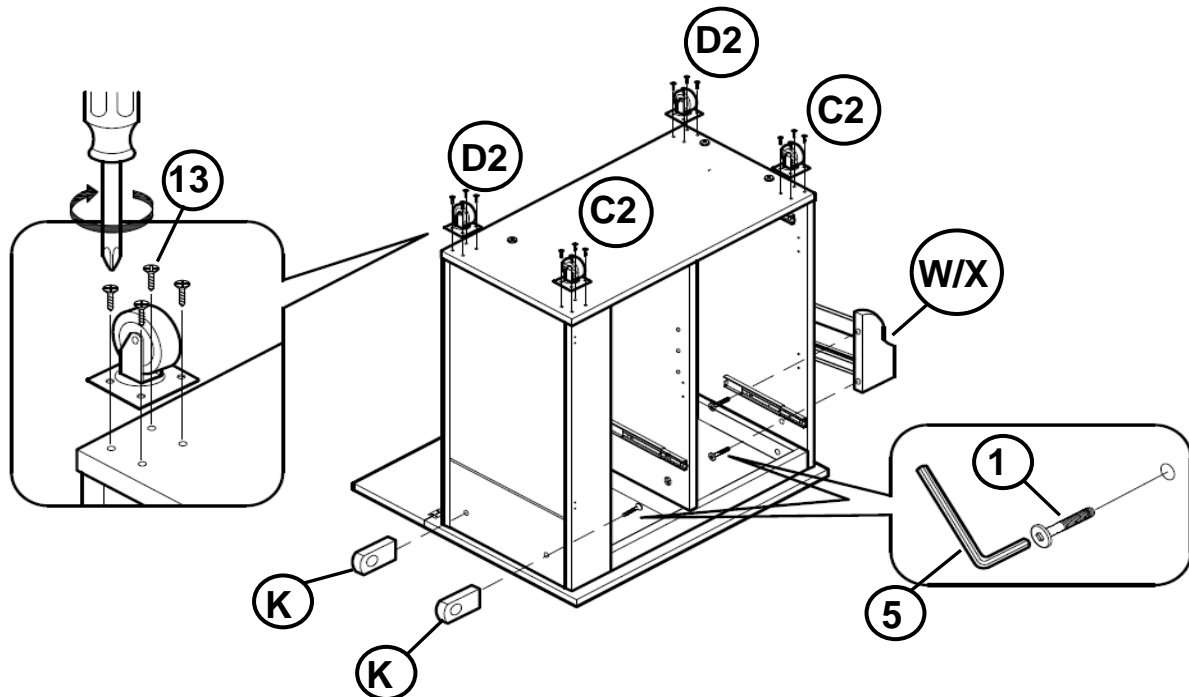



ITEM: 900558



**ASSEMBLY INSTRUCTIONS**  
**STEP 8**

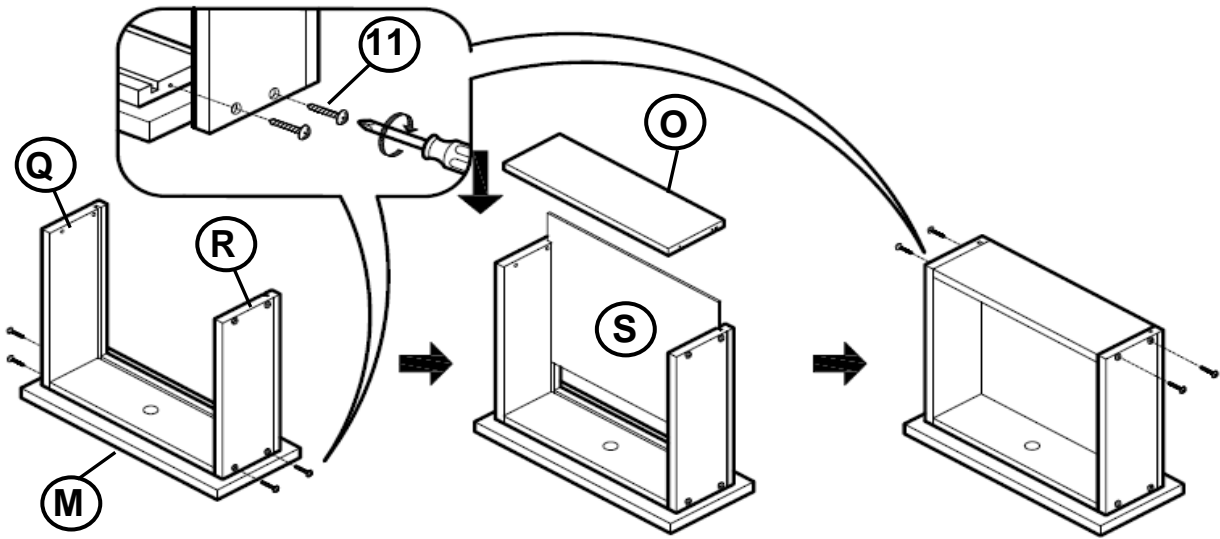

**STEP 9**

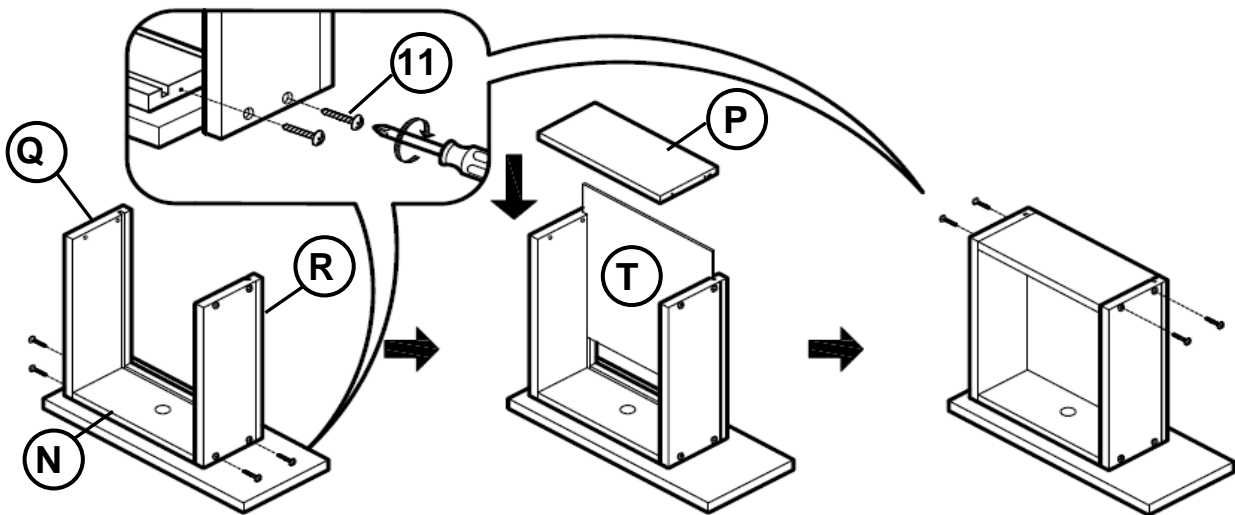

**STEP 10**

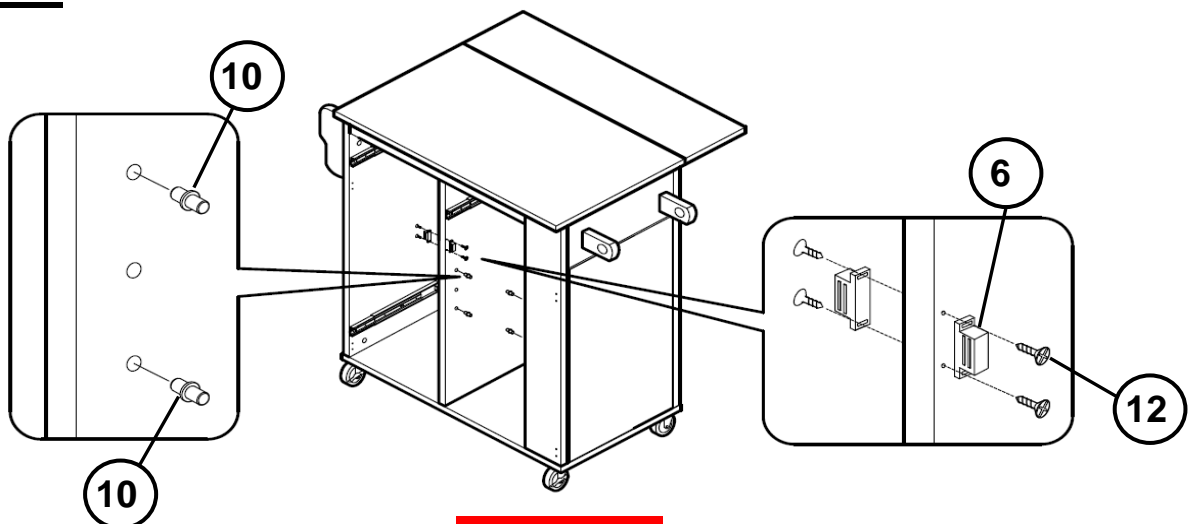

ITEM: **900558**



**ASSEMBLY INSTRUCTIONS**

**STEP 11**

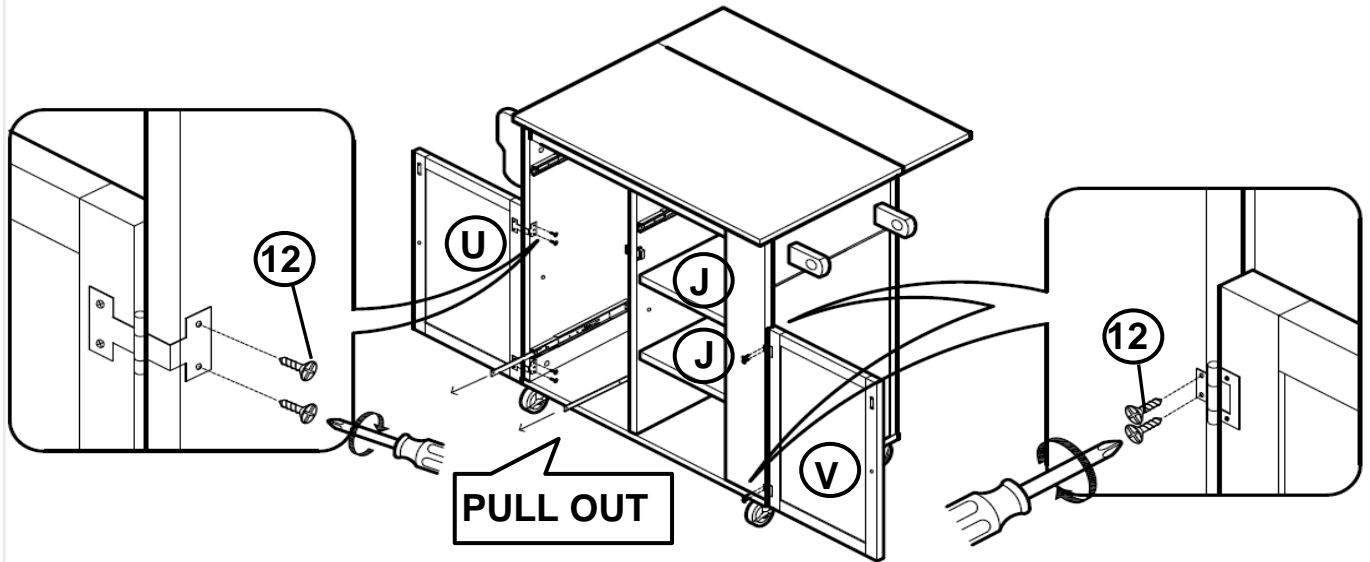

**STEP 12**

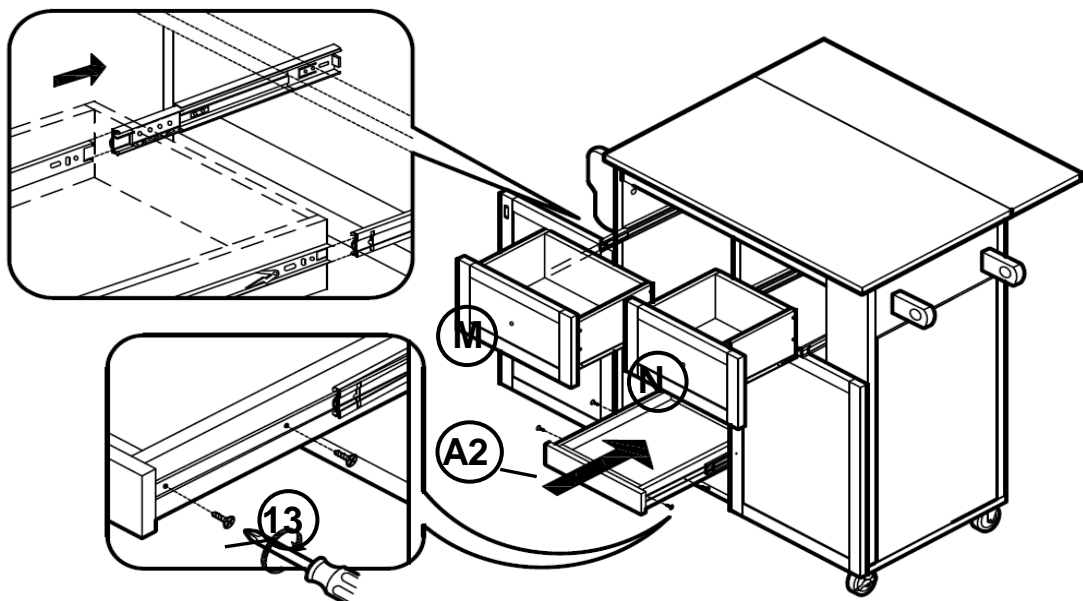

ITEM: **900558**



**ASSEMBLY INSTRUCTIONS**

**STEP 13**

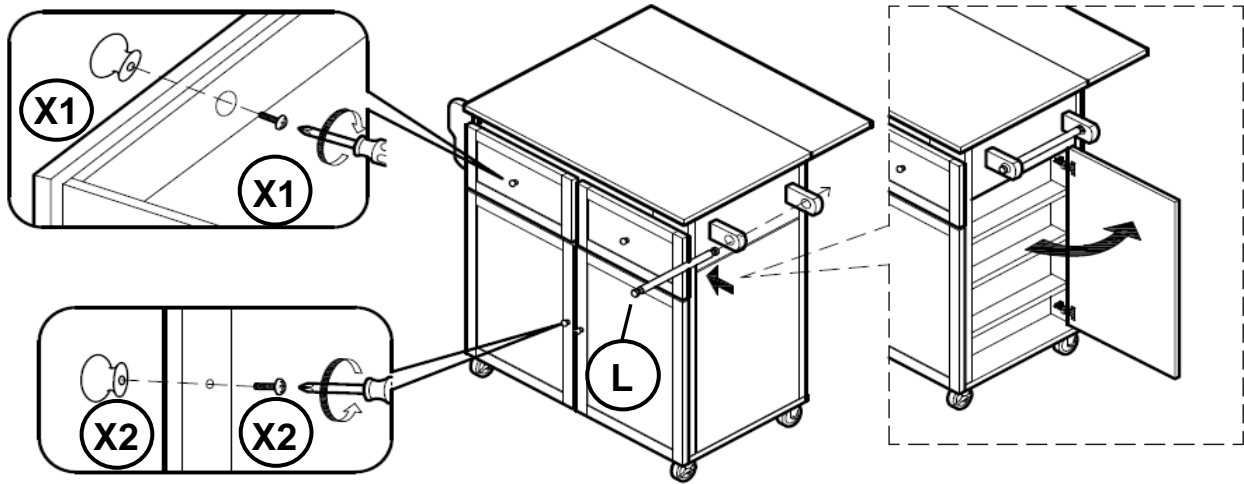

**Side Door Open Preview**

**STEP 14**

**COMPLETE**

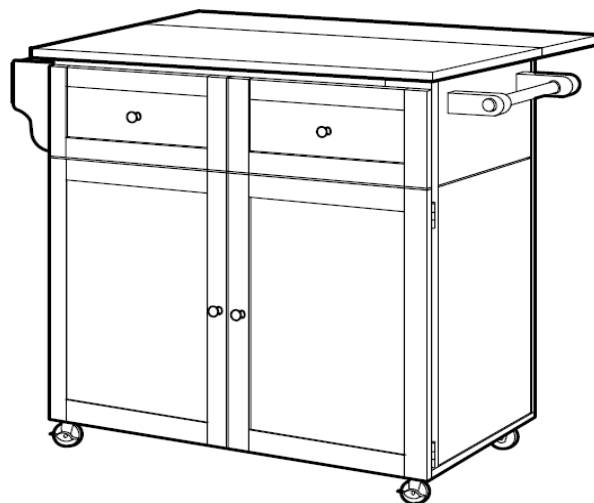

ITEM: **900558**



**INNER SIZE OF DRAWER A : 4.96" X 13.58" X 12.6"**  
**INNER SIZE OF DRAWER B : 4.96" X 9.53" X 12.6"**  
**INNER SIZE OF DRAWER C : 14.56" X 13.54" X 1.57"**

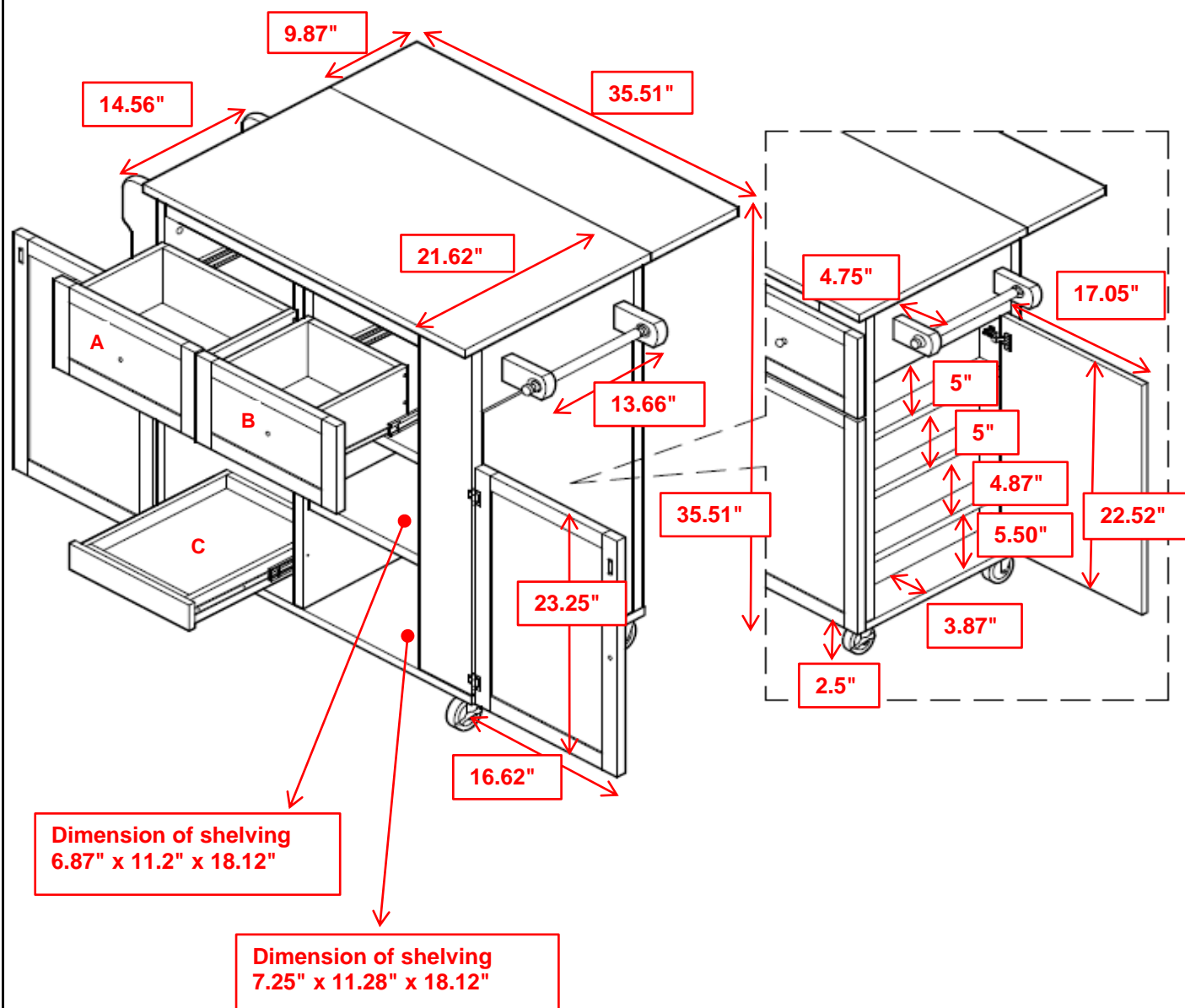

**Note :** Dimension tolerance  $\pm 5\%$