

ASSEMBLY INSTRUCTIONS
COASTER FINE FURNITURE



Fine Furniture for every stage of life

110280
Dining Table

ITEM: 110280



ASSEMBLY INSTRUCTIONS

ASSEMBLY TIPS:

1. Remove hardware from box and sort by size.
2. Please check to see that all hardware and parts are present prior to start of assembly.
3. Please follow attached instructions in the same sequence as numbered to assure fast & easy assembly.



WARNING!

1. Don't attempt to repair or modify parts that are broken or defective. Please contact the store immediately.
2. This product is for home use only and not intended for commercial establishments.



ASSEMBLY TIME

10 MINUTES

PARTS IDENTIFICATION

A	TOP		1PC	C	MAIN POST		1PC
B	METAL CONNECTING PLATE		1PC	D	BASE		1PC

HARDWARE IDENTIFICATION

1	ALLEN SCREW (M6*25)		8pcs	6	ALLEN KEY (10MM)		1PC
2	ALLEN KEY (4MM)		1PC	7	MESON (Φ55*6)		1PC
3	ALLEN SCREW (M12*30)		1PC	8	ALLEN SCREW (M8*30)		3PCS
4	SPRING WASHER (Φ12*2.5)		2PCS	9	ALLEN KEY (5MM)		1PC
5	ALLEN SCREW (M12*70)		1PC				

NOTE:

Phillips head screw driver is required in the assembly process; however, manufacturer does not provide this item.

ITEM: **1010280**



ASSEMBLY INSTRUCTIONS

STEP 1

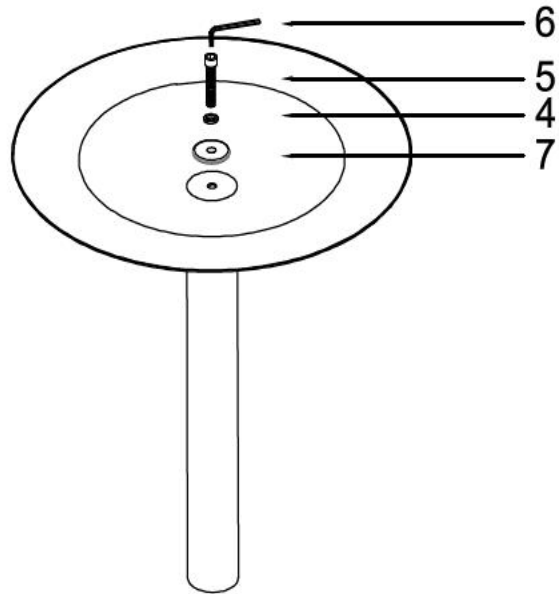

STEP 2

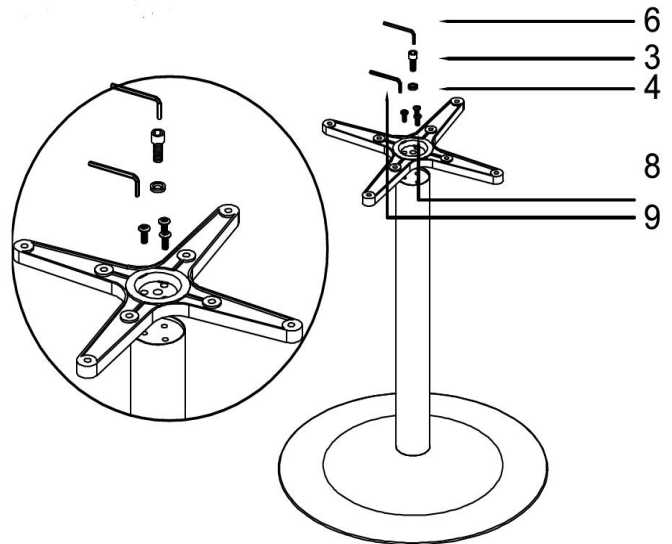

STEP 3

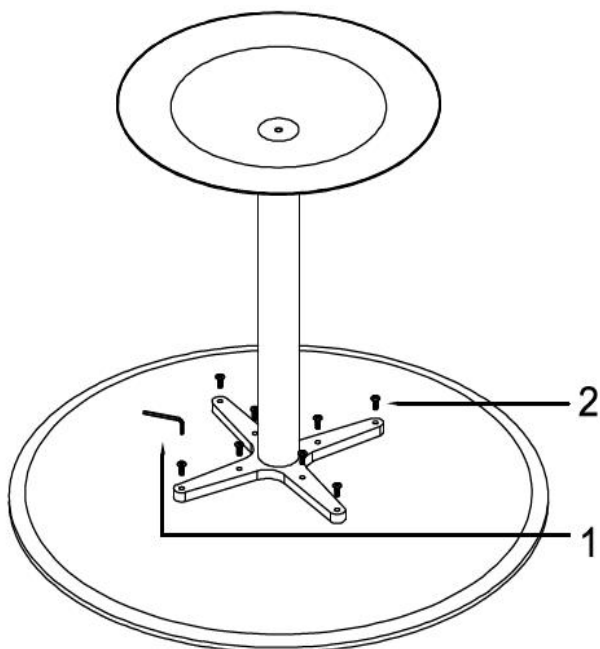

STEP 4 **COMPLETE**

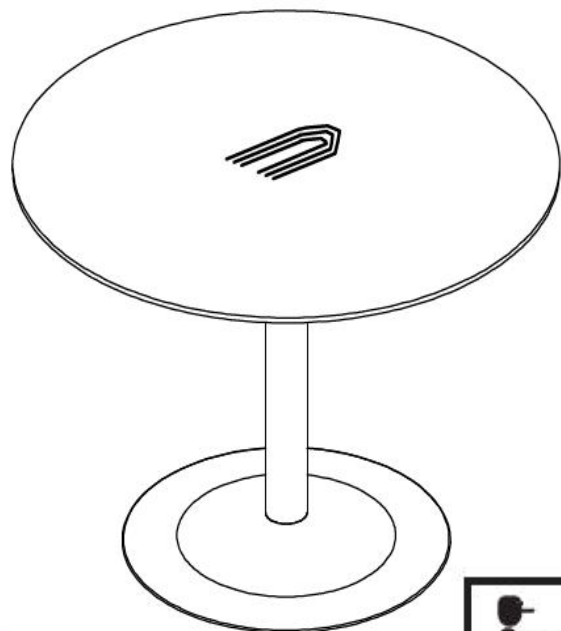

ITEM: **110280**

