

ASSEMBLY INSTRUCTIONS COASTER FINE FURNITURE



Fine Furniture for every stage of life

802141
WRITING DESK

ITEM: **802141**

ASSEMBLY INSTRUCTIONS



STEP 1: Don't tighten all bolts on this step

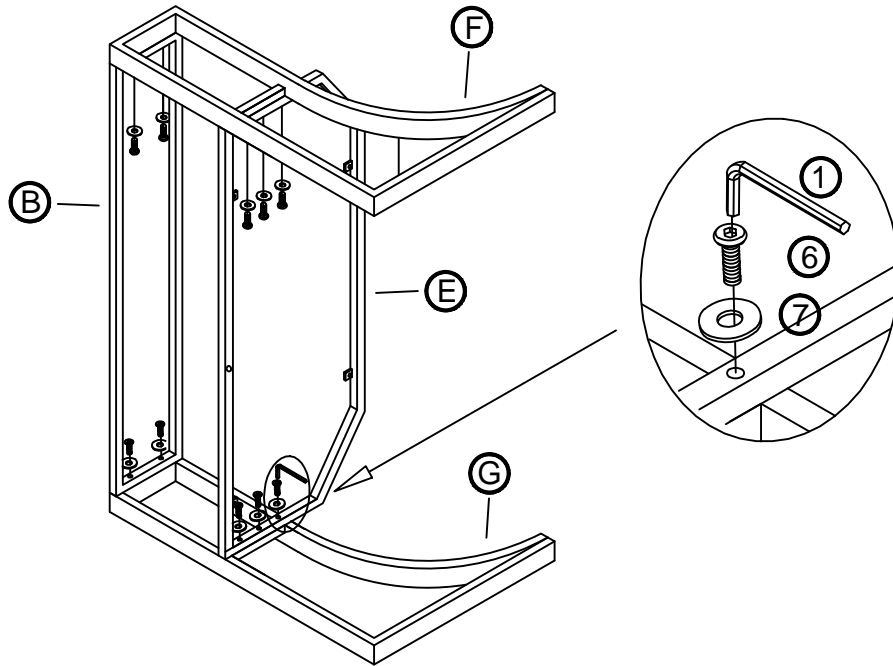

STEP 2

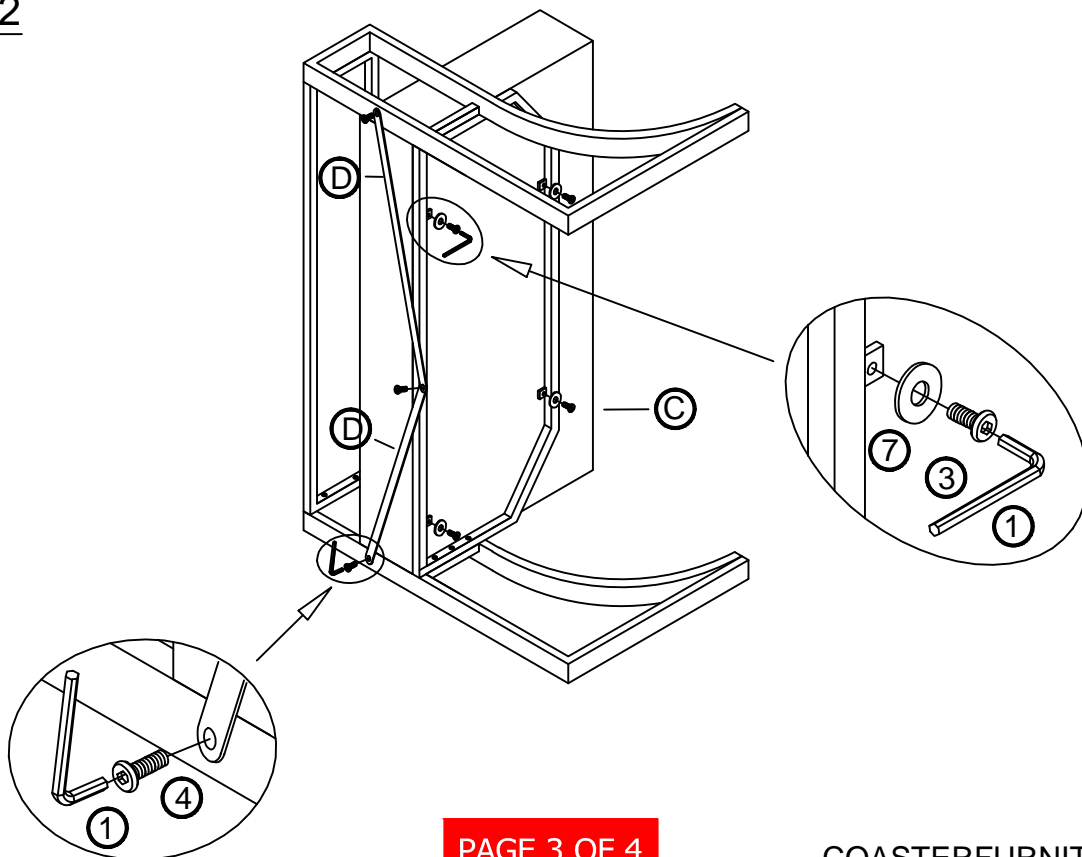

ITEM: **802141**

ASSEMBLY INSTRUCTIONS



STEP 3

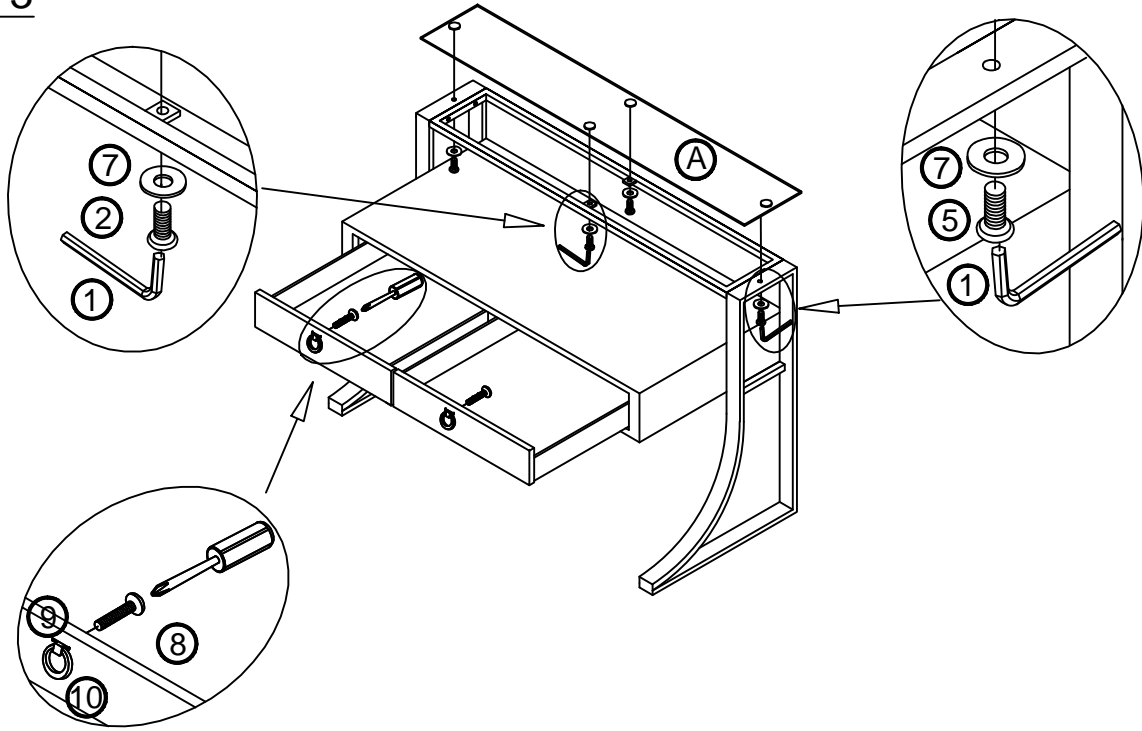

STEP 4: Tighten all screws on this step
COMPLETE

