



*ASSEMBLY INSTRUCTIONS
COASTER FINE FURNITURE*



Fine Furniture for every stage of life

111101
DINING TABLE

ITEM: 111101 (B1-B3)



ASSEMBLY INSTRUCTIONS

ASSEMBLY TIPS:

1. Remove hardware from box and sort by size.
2. Please check to see that all hardware and parts are present prior to start of assembly.
3. Please follow attached instructions in the same sequence as numbered to assure fast & easy assembly.



WARNING!

1. Don't attempt to repair or modify parts that are broken or defective. Please contact the store immediately.
2. This product is for home use only and not intended for commercial establishments.



ASSEMBLY TIME

10

PARTS IDENTIFICATION

B1 (BOX 1)

A TOP MARBLE

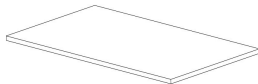

1PCS

B2 (BOX 2)

B TOP FRAME

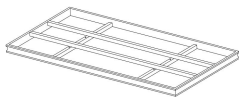

1PCS

C BASE

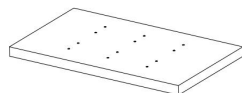

1PCS

B3 (BOX 3)

D LEG FRAME

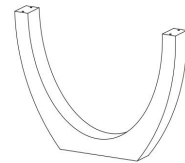

2PCS

NOTE:

Phillips head screw driver is required in the assembly process; however, manufacturer does not provide this item.

ITEM:111101 (B1-B3)



ASSEMBLY INSTRUCTIONS

ASSEMBLY TIPS:

1. Remove hardware from box and sort by size.
2. Please check to see that all hardware and parts are present prior to start of assembly.
3. Please follow attached instructions in the same sequence as numbered to assure fast & easy assembly.





WARNING!

1. Don't attempt to repair or modify parts that are broken or defective. Please contact the store immediately.
2. This product is for home use only and not intended for commercial establishments.

HARDWARE IDENTIFICATION

Z-B2 (BOX 2) - HARDWARE PACK IS LOCATED IN 111101 (B3)

1 ALLEN WRENCH		1PCS
2 SHORT BOLT (M8*55mm)		20PCS
3 FLAT WASHER D20*2		20PCS
4 FRAME REST		8PCS

Hardware pack is located in 111101 B3

NOTE:

Phillips head screw driver is required in the assembly process; however, manufacturer does not provide this item.

ITEM:111101 (B1-B3)

ASSEMBLY INSTRUCTIONS

STEP 1

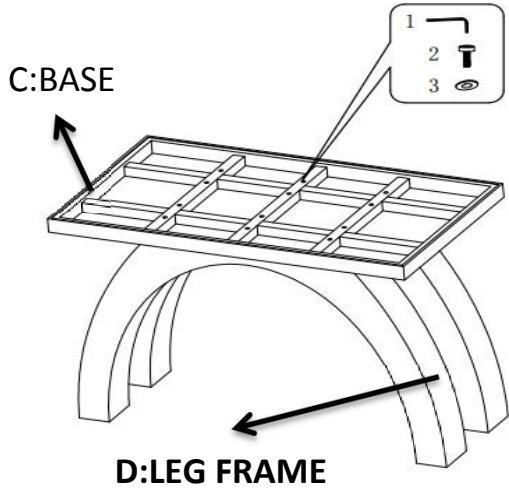

STEP 2

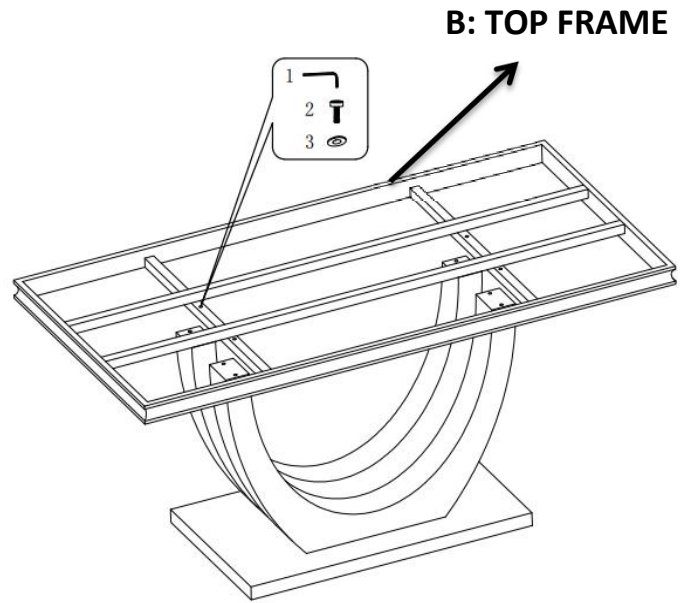

STEP 3

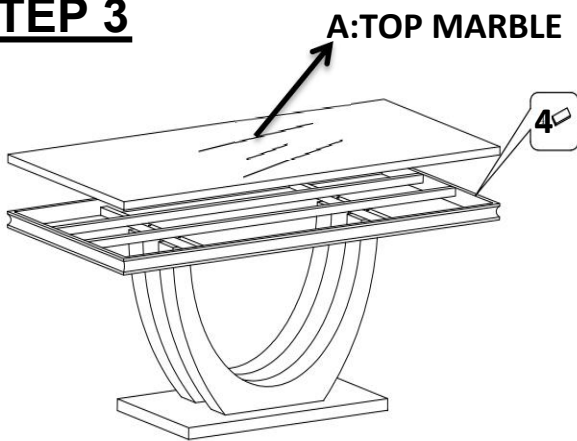

STEP 4

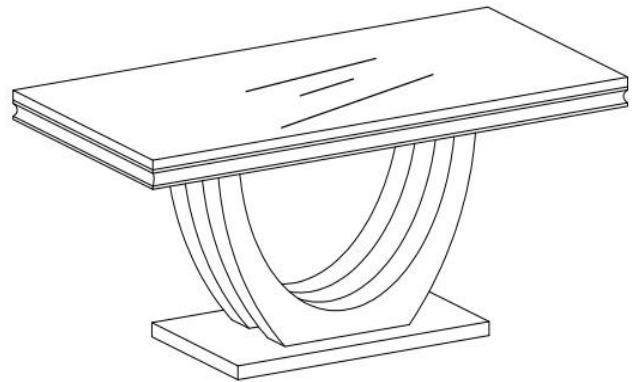

ITEM:111101 (B1-B3)

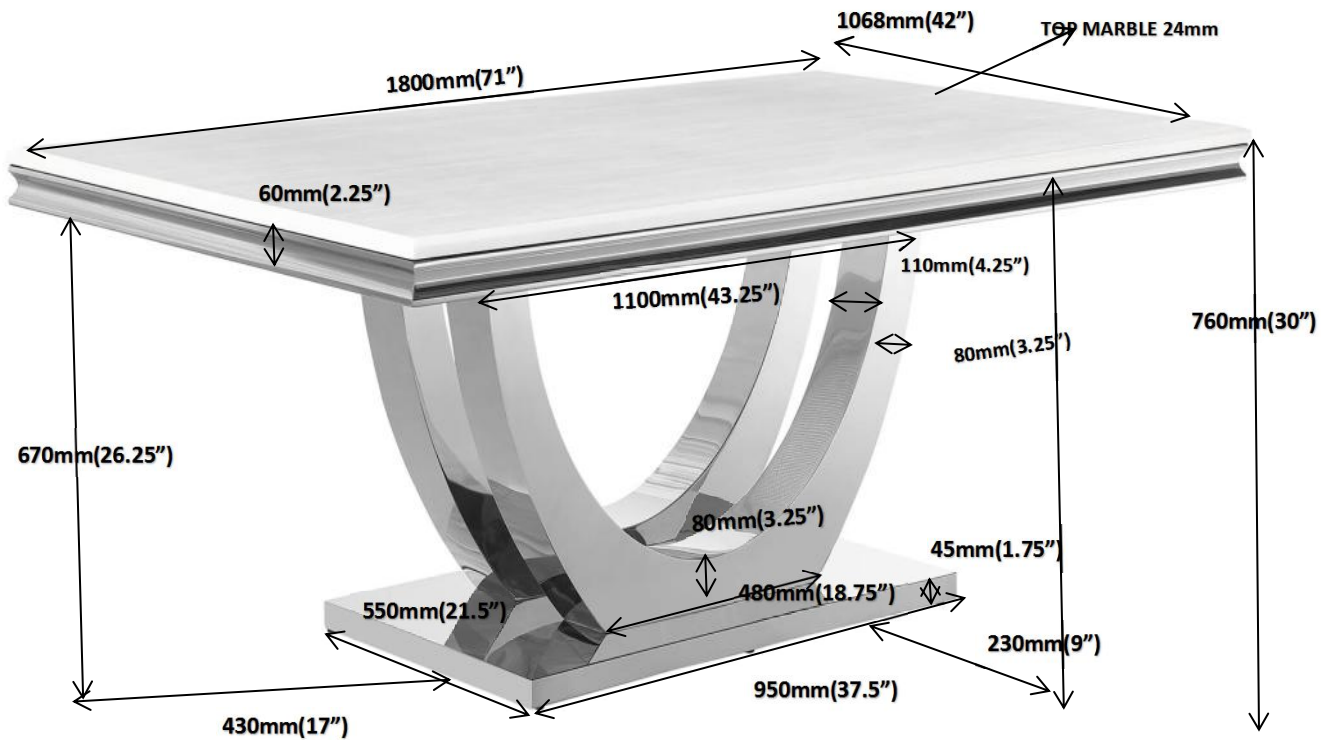

Note : Dimension tolerance $\pm 5\%$