

ASSEMBLY INSTRUCTIONS
COASTER FINE FURNITURE



Fine Furniture for every stage of life

801235
WRITING DESK

ITEM:801235



ASSEMBLY INSTRUCTIONS

ASSEMBLY TIPS:

1. Remove hardware from box and sort by size.
2. Please check to see that all hardware and parts are present prior to start of assembly.
3. Please follow attached instructions in the same sequence as numbered to assure fast & easy assembly.



WARNING!









1. Don't attempt to repair or modify parts that are broken or defective. Please contact the store immediately.
2. This product is for home use only and not intended for commercial establishments.

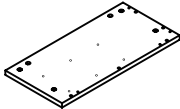

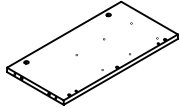
ASSEMBLY TIME

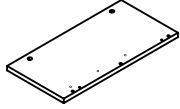
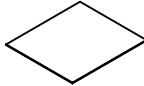
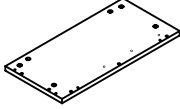
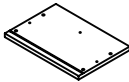
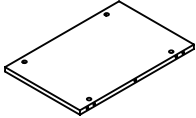
40 MINUTES

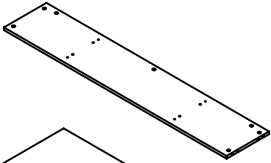
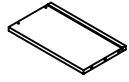
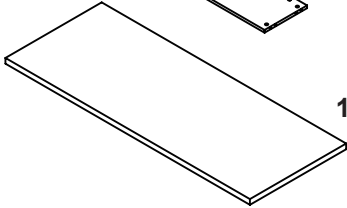
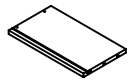
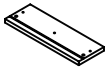
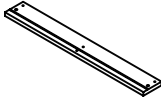
PARTS IDENTIFICATION









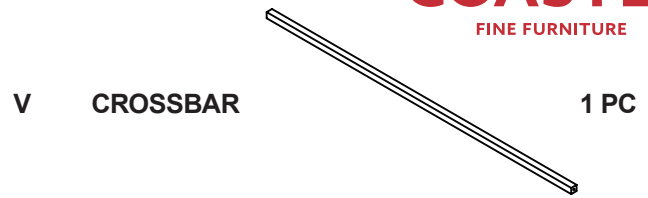
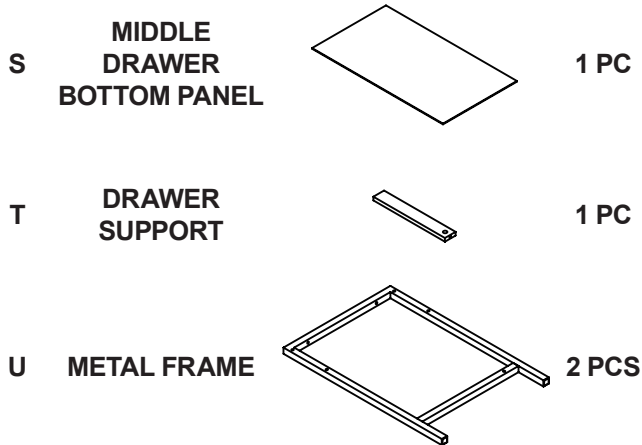

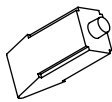

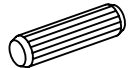
A	LEFT SIDE PANEL		1 PC	J	LEFT DRAWER LEFT SIDE PANEL		3 PCS
B	LEFT DIVIDER PANEL		1 PC	K	LEFT DRAWER RIGHT SIDE PANEL		3 PCS
C	RIGHT DIVIDER PANEL		1 PC	L	DRAWER BOTTOM PANEL		3 PCS
D	RIGHT SIDE PANEL		1 PC	M	RIGHT DRAWER FRONT PANEL		1 PC
E	BOTTOM PANEL		2 PCS	N	RIGHT DRAWER BACK PANEL		1 PC
F	BACK PANEL		1 PC	O	RIGHT DRAWER LEFT SIDE PANEL		1 PC
G	TOP		1 PC	P	RIGHT DRAWER RIGHT SIDE PANEL		1 PC
H	LEFT DRAWER FRONT PANEL		2 PCS	Q	MIDDLE DRAWER FRONT PANEL		1 PC
I	LEFT DRAWER BACK PANEL		2 PCS	R	MIDDLE DRAWER BACK PANEL		1 PC

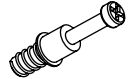
NOTE:

Phillips head screw driver is required in the assembly process; however, manufacturer does not provide this item.

ITEM: 801235

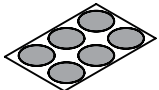

Z <u>HARDWARE IDENTIFICATION</u>							
NO	DESCRIPTION	FIGURE	Q'TY	NO	DESCRIPTION	FIGURE	Q'TY
1	GLUE 40g		1 PC	8	SCREW FOR RAIL Ø3.5x12mm SR		40 PCS
2	WOODEN DOWEL Ø8x30mm		44 PCS	9	KNOB		4 PCS
3	CAM BOLT Ø7x35.5mm SR		32 PCS	10	KNOB BOLT Ø4x28mm BLK		4 PCS
4	CAM LOCK Ø15x12mm SR		32 PCS	11	BOLT M6x43mm BLK		14 PCS
5	LONG SCREW Ø4.5x42mm SR		4 PCS	12	ALLEN WRENCH 4mm SR		1 PC
6	SCREW Ø4.3x35mm SR		17 PCS	13	STICKER Ø20mm		6 PCS
7	RAIL L = 350mm SR		4 SET				

Z7 not included in blister packaging.

NOTE:

Phillips head screw driver is required in the assembly process; however, manufacturer does not provide this item.

ITEM: 801235

COASTER
FINE FURNITURE

STEP 1

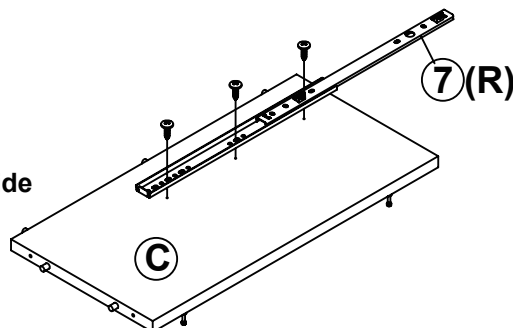
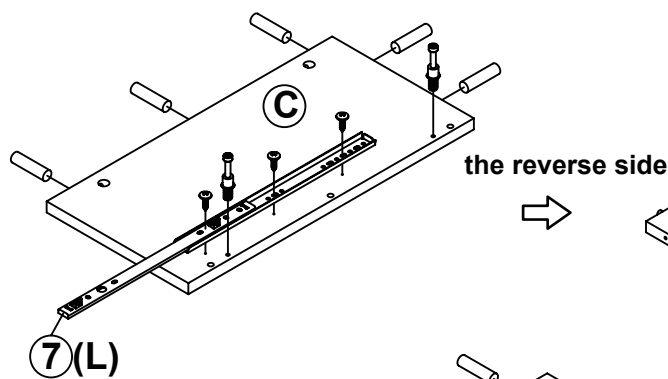
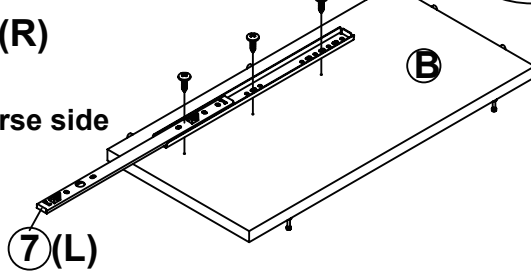
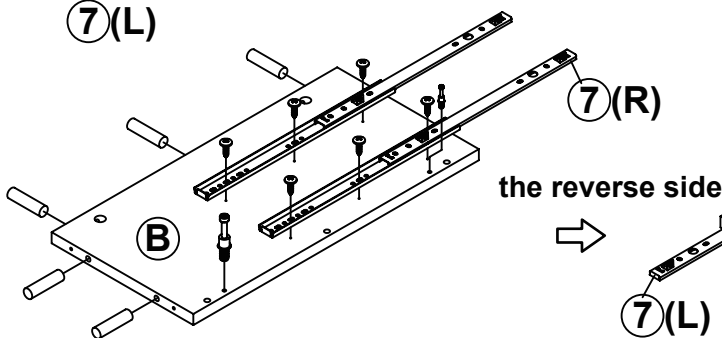
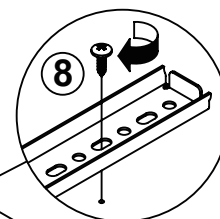
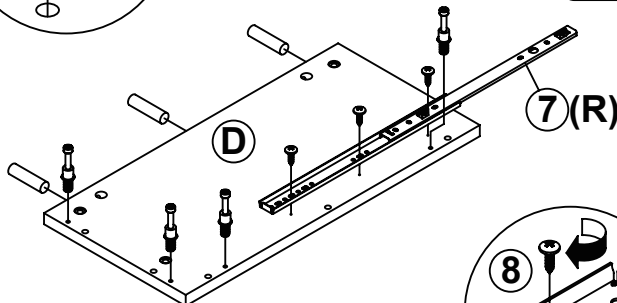
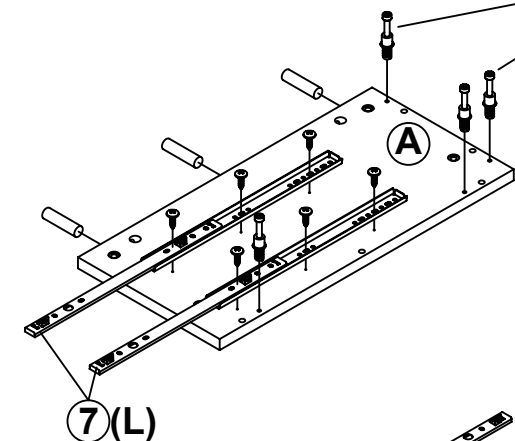
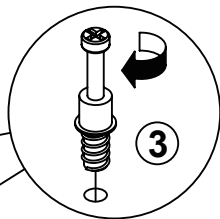
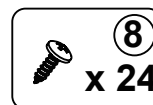
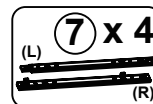
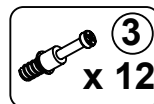
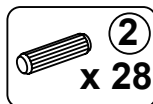

Apply glue on all wooden dowels to ensure integrity of the structure.

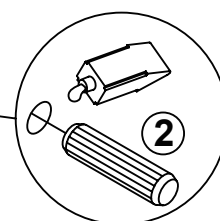
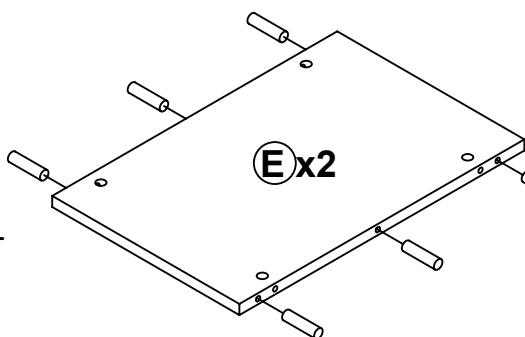

INCORRECT CORRECT

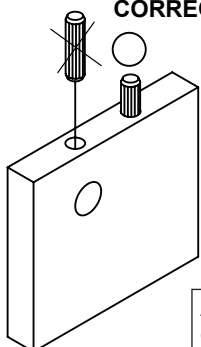

Apply glue on all wooden dowels to ensure integrity of the structure.

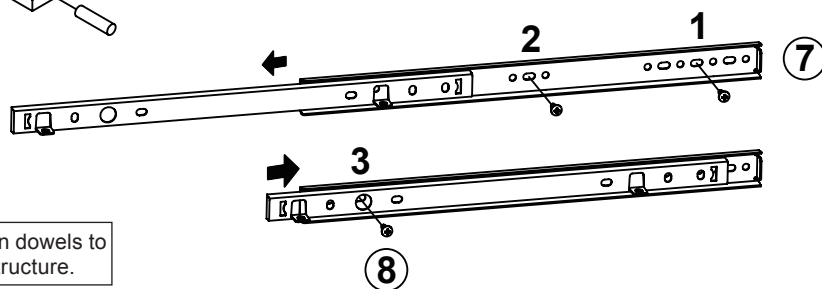

ITEM: 801235

STEP 2

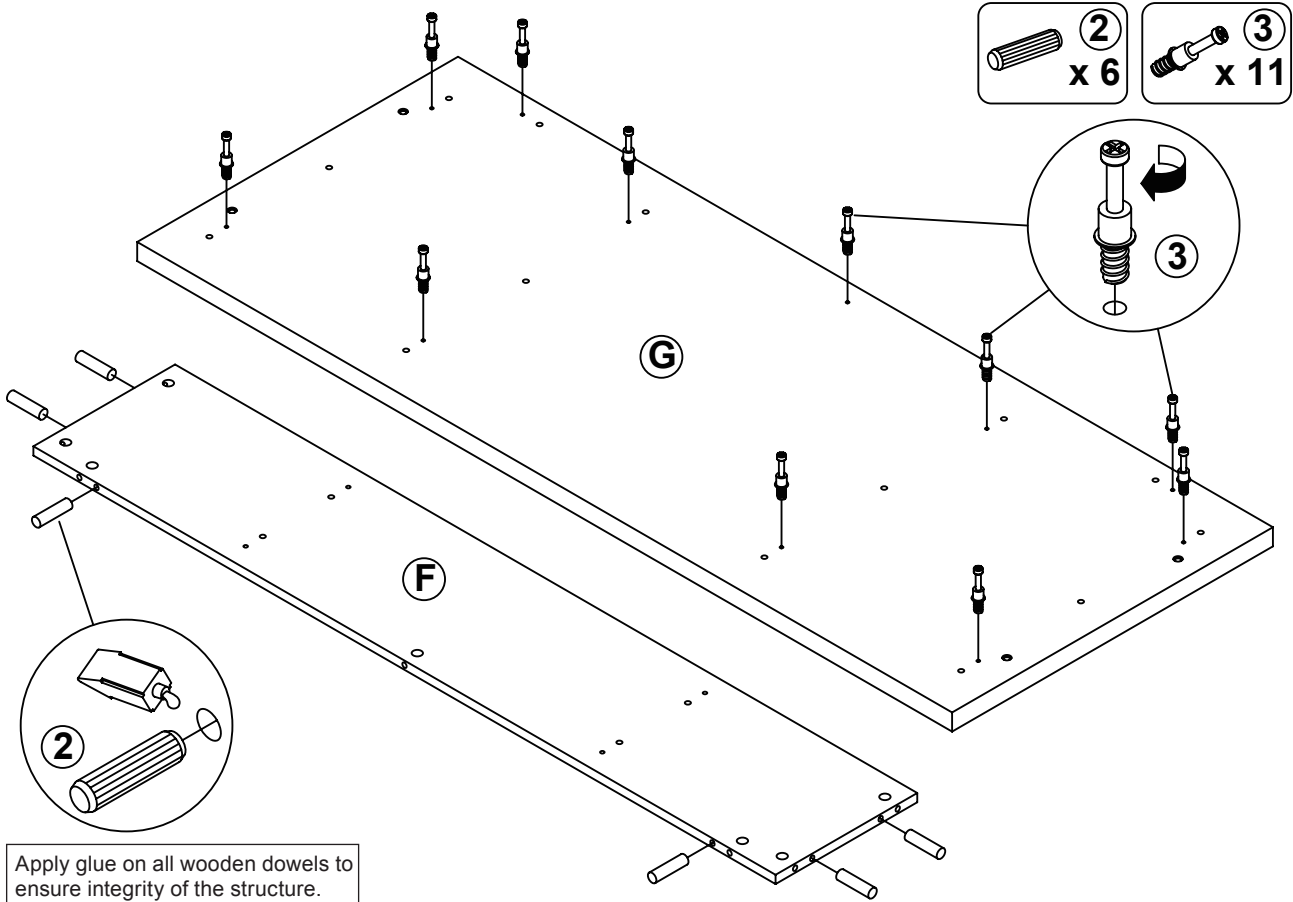

STEP 3

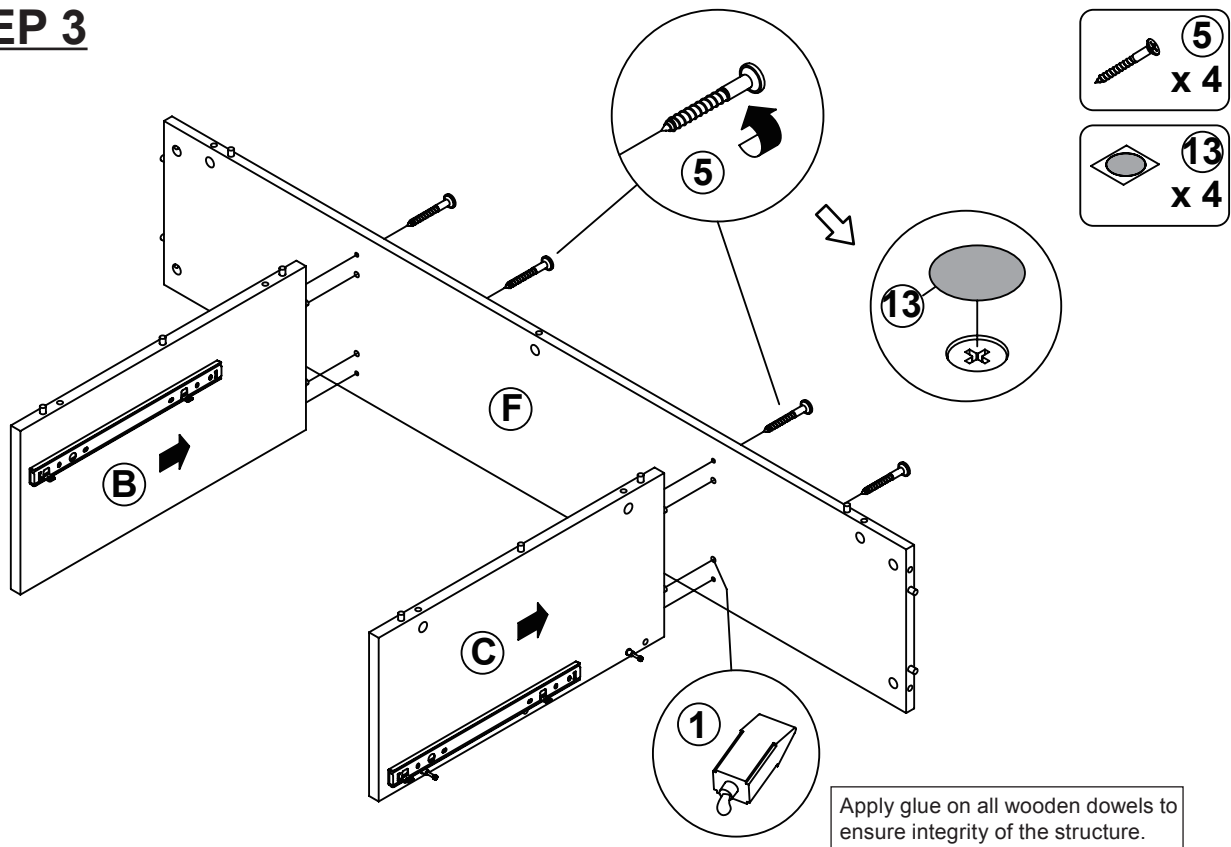

ITEM: 801235

STEP 4

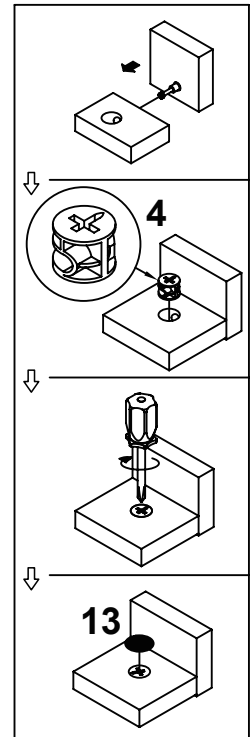
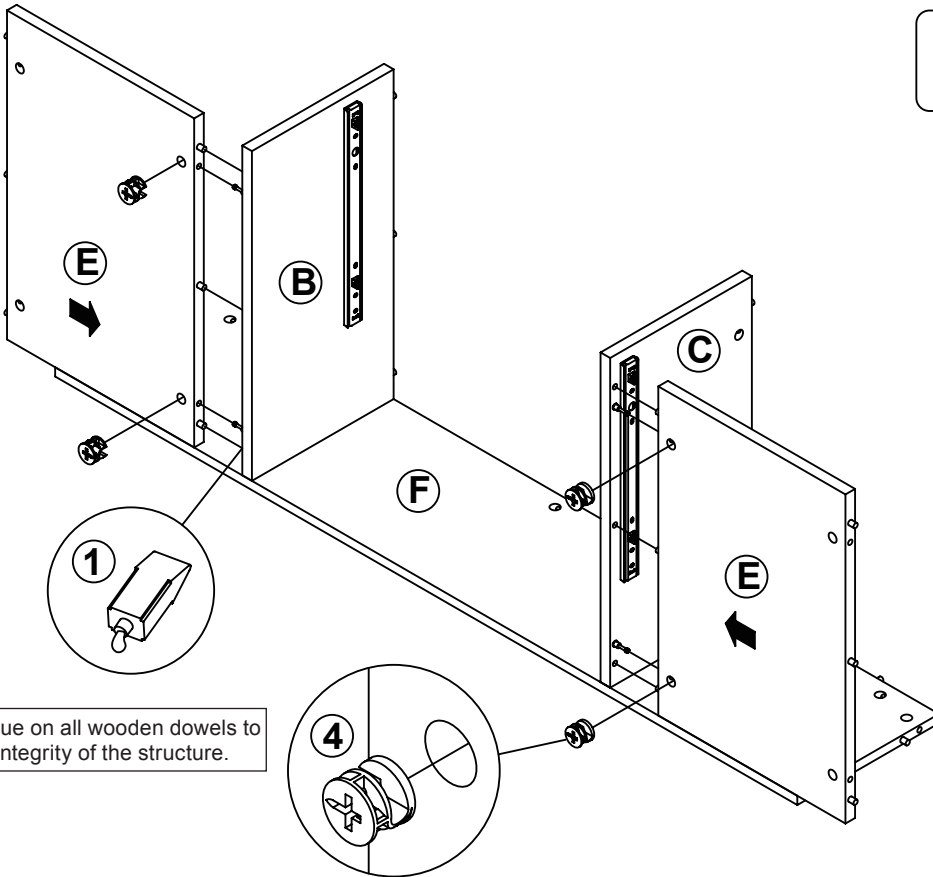
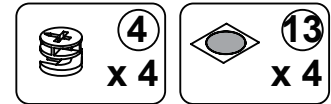

Apply glue on all wooden dowels to ensure integrity of the structure.

STEP 5

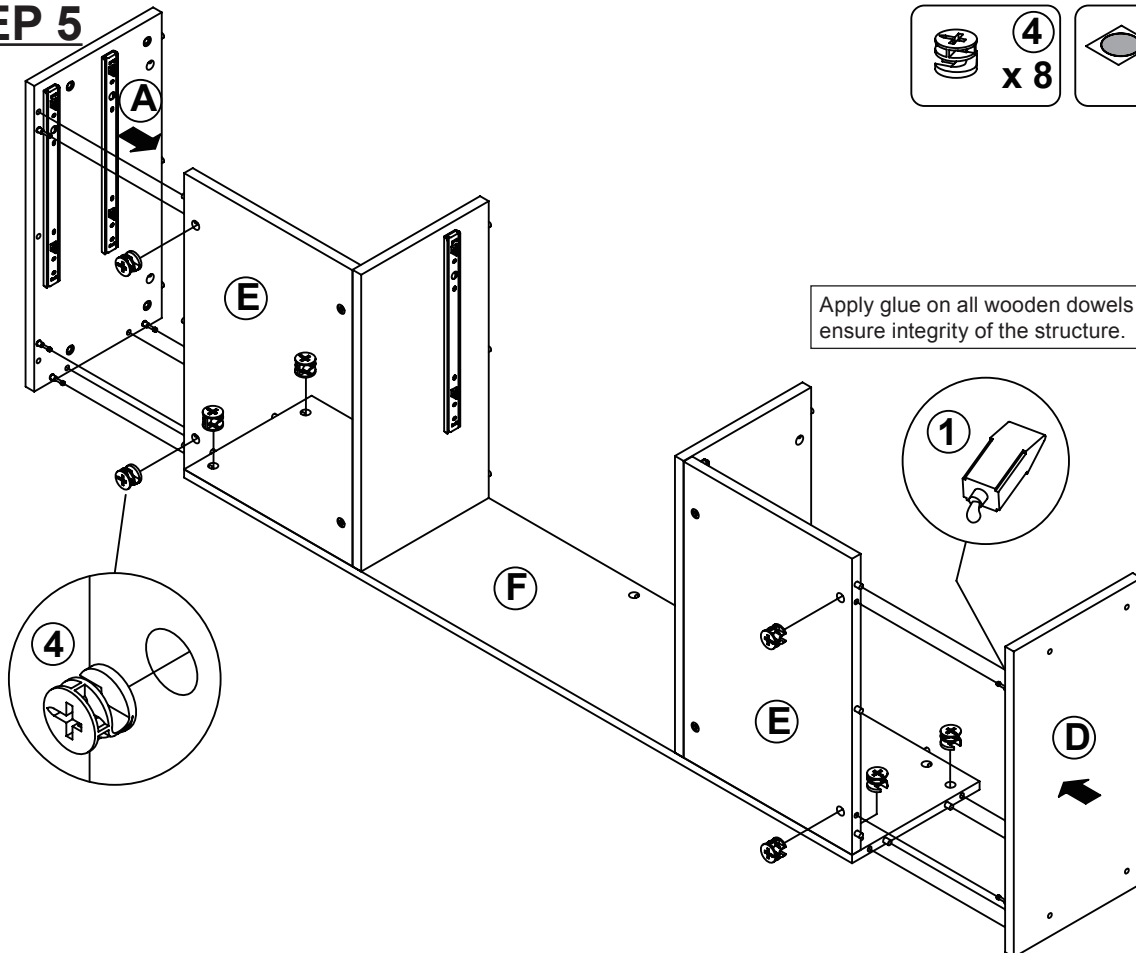

Apply glue on all wooden dowels to ensure integrity of the structure.

ITEM: 801235

COASTER
FINE FURNITURE

STEP 6

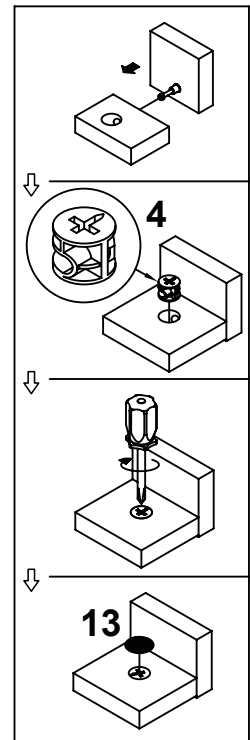
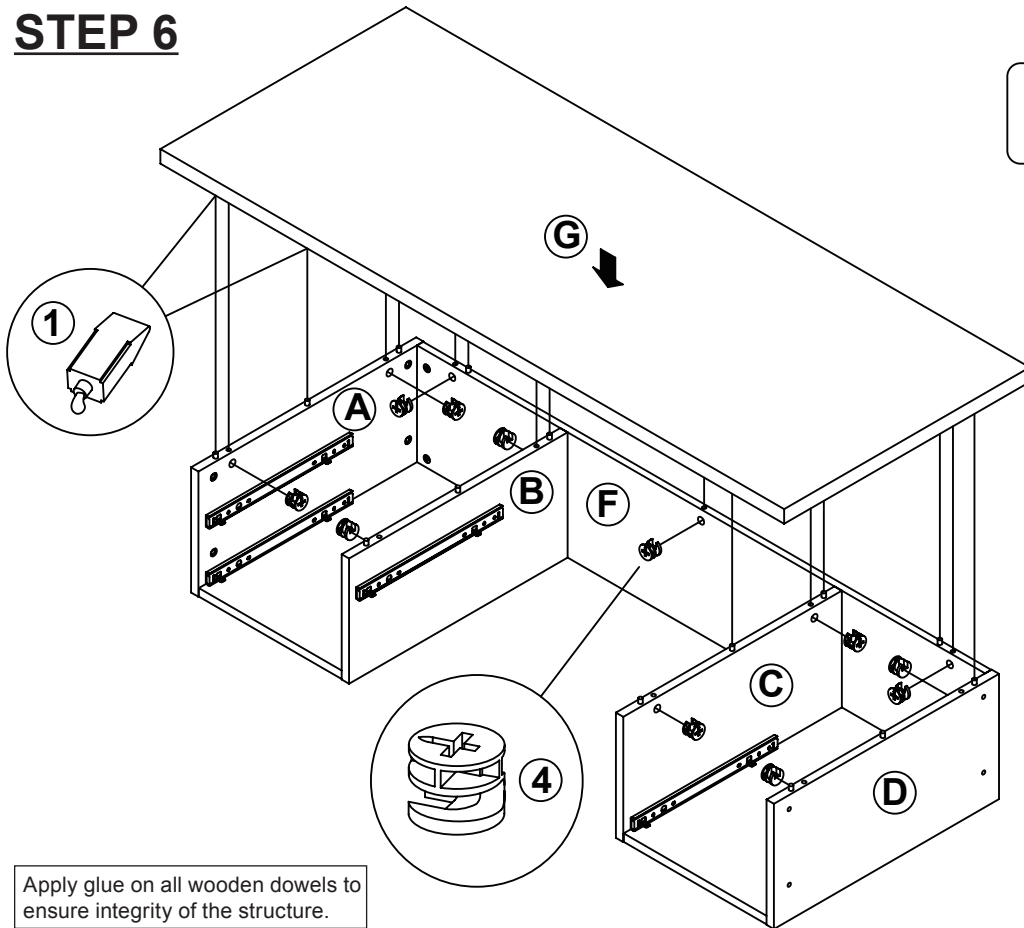
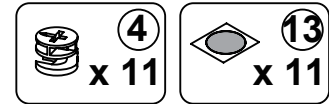

STEP 7

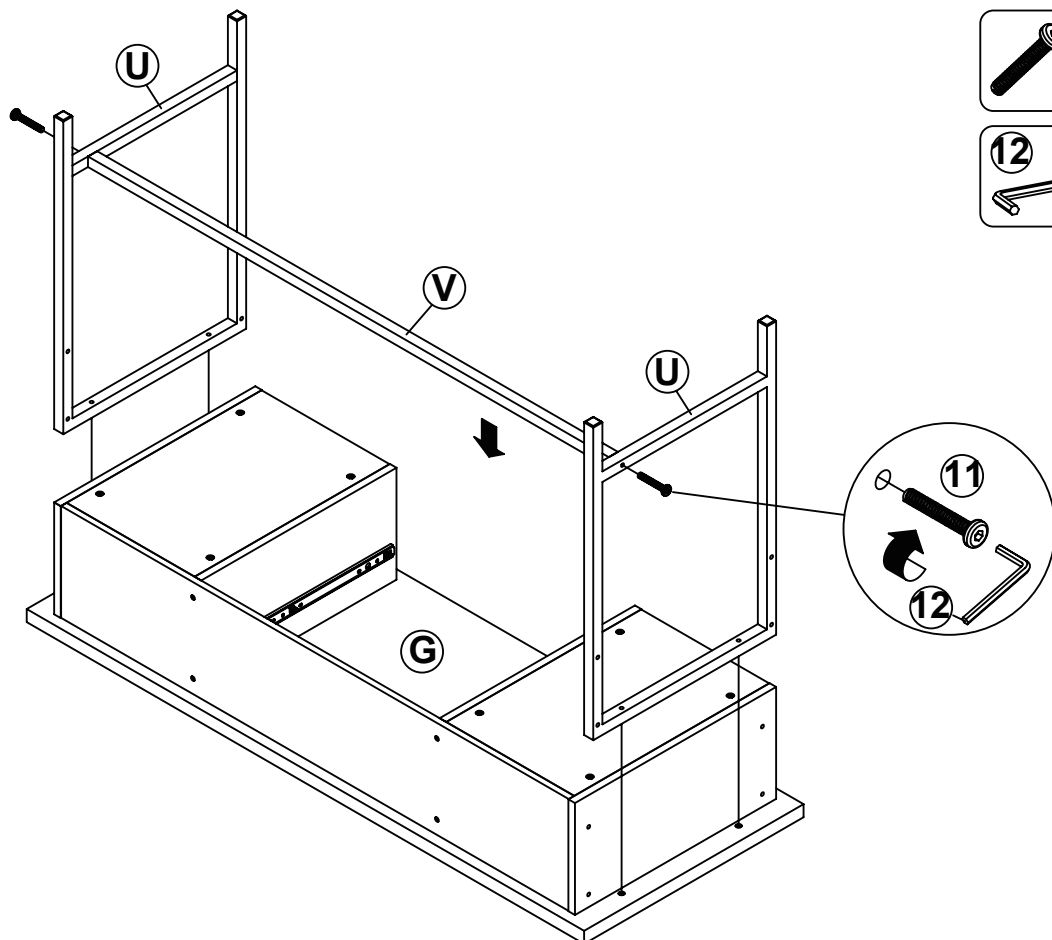
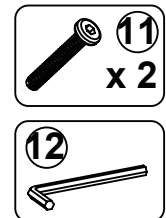

ITEM: 801235

COASTER
FINE FURNITURE

STEP 8

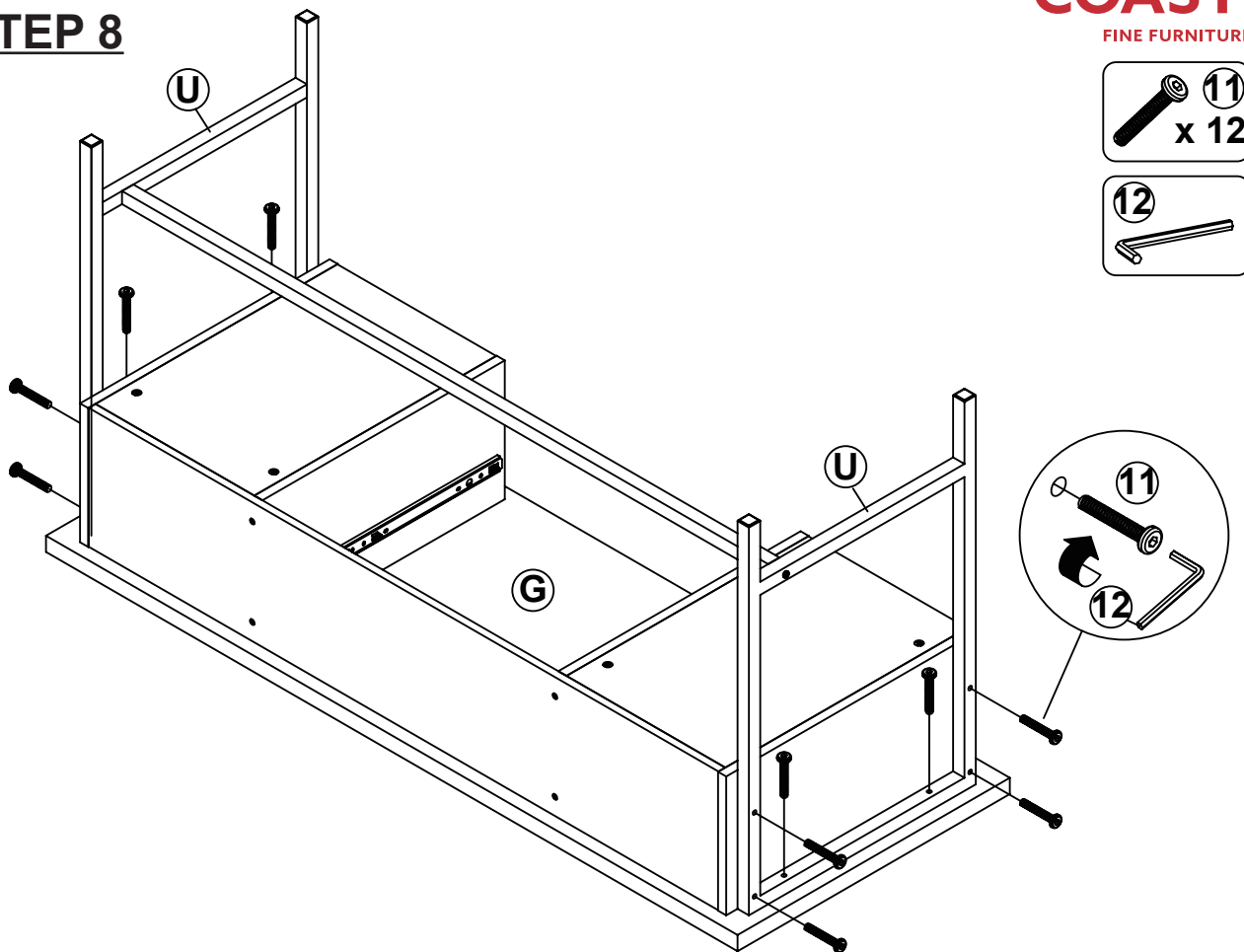

STEP 9-1

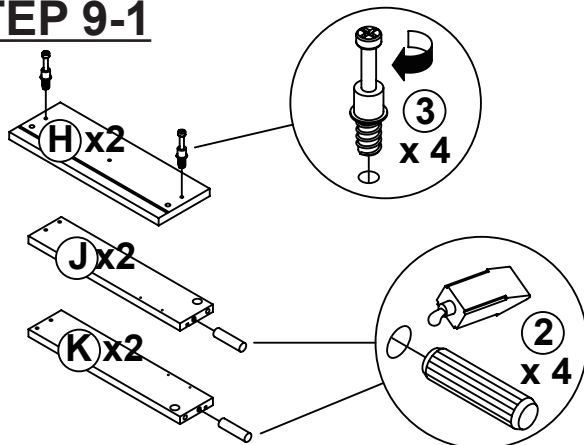

STEP 9-2

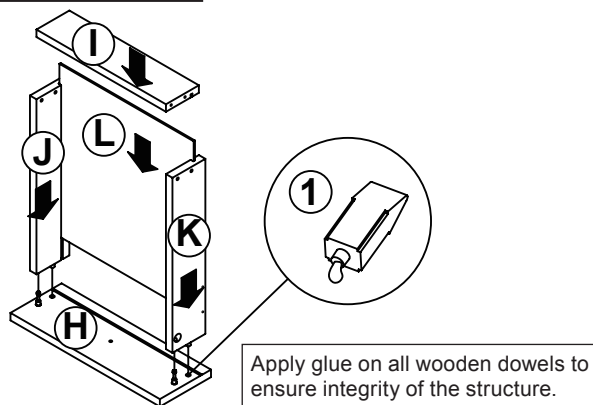

STEP 9-3

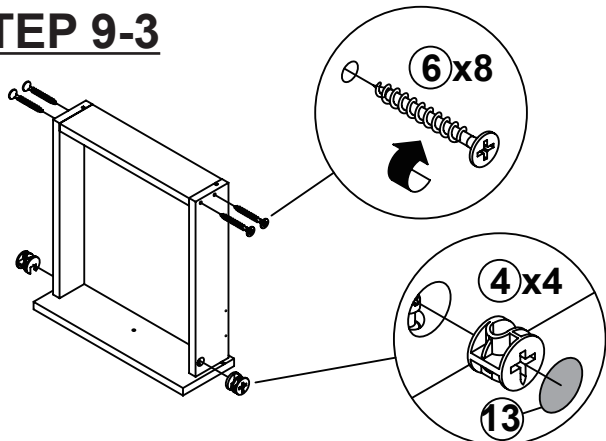

STEP 9-4

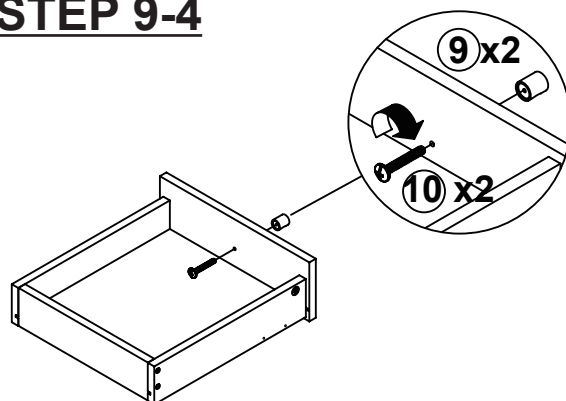

STEP 10-1

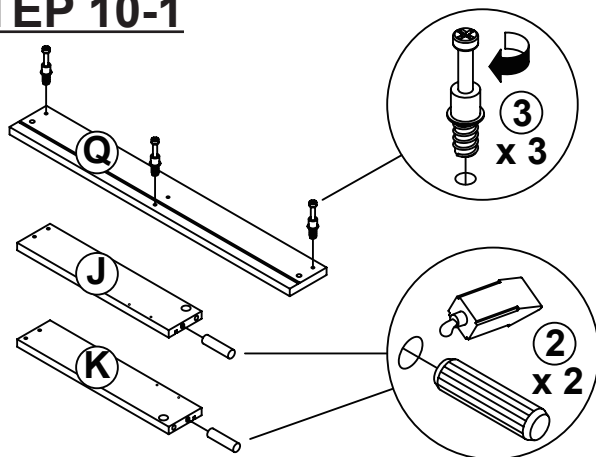

STEP 10-2

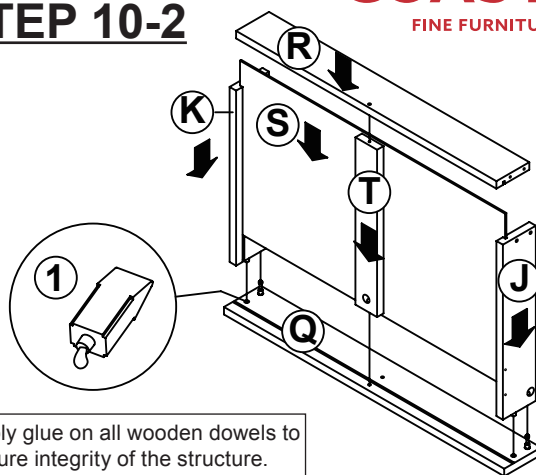

STEP 10-3

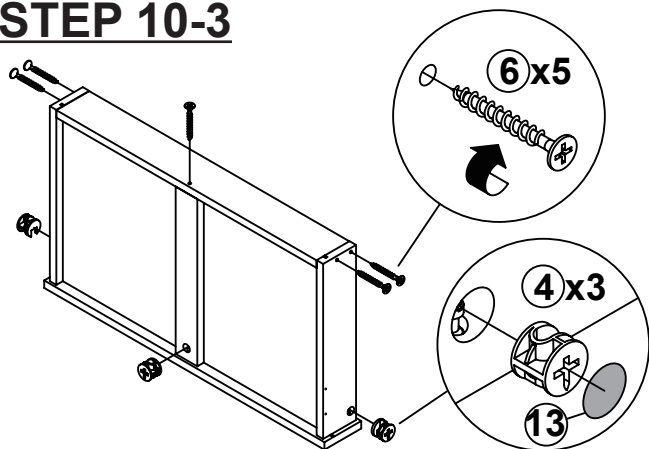

STEP 10-4

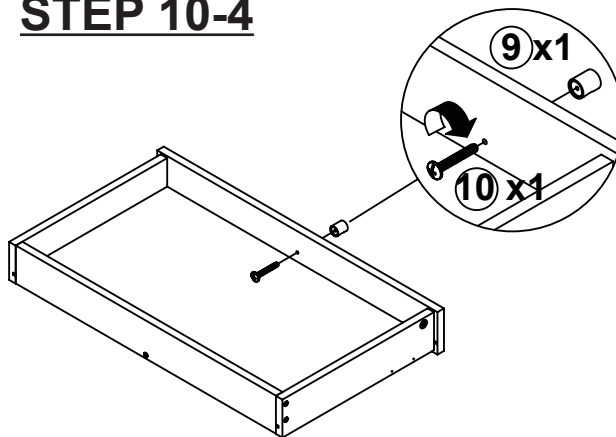

STEP 11-1

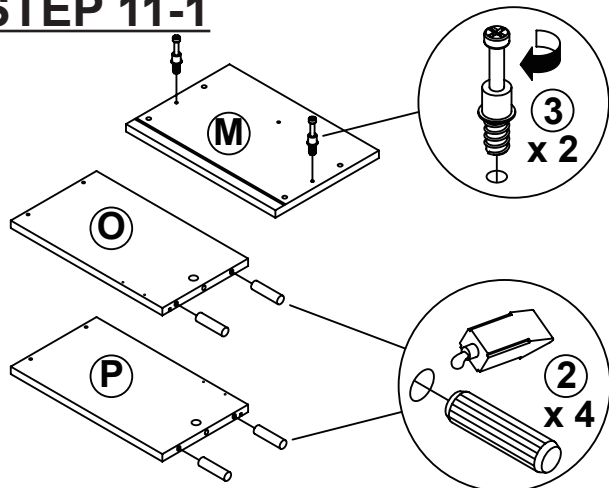

STEP 11-2

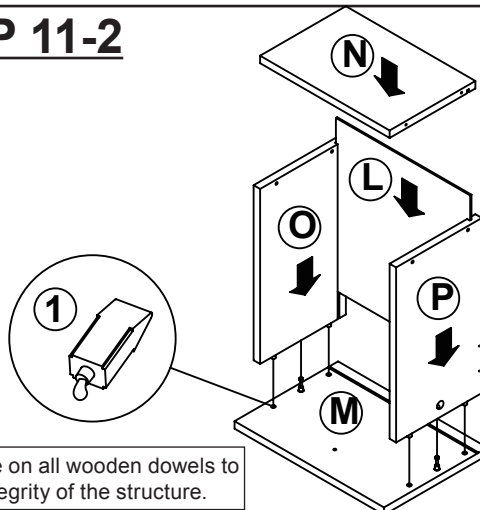

STEP 11-3

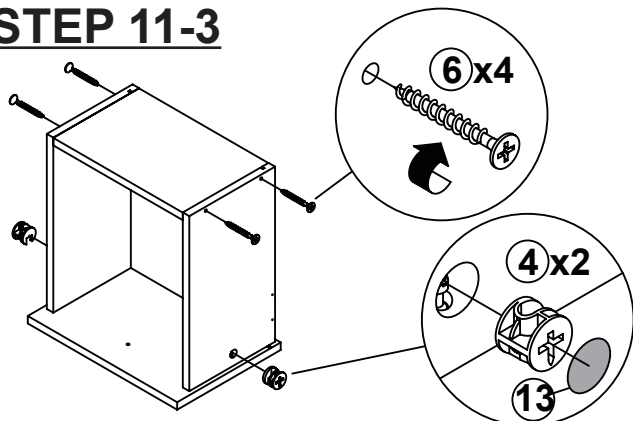

STEP 11-4

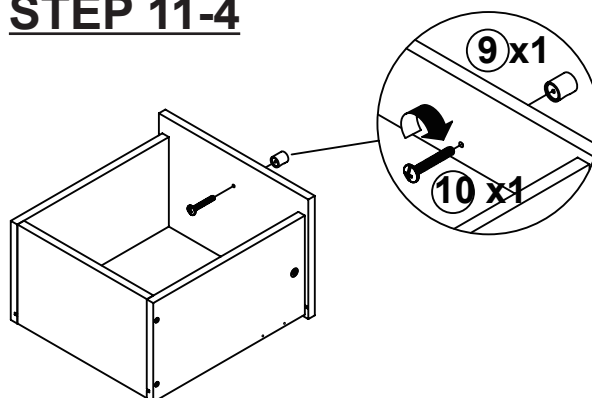

ITEM: 801235

COASTER
FINE FURNITURE

STEP 12

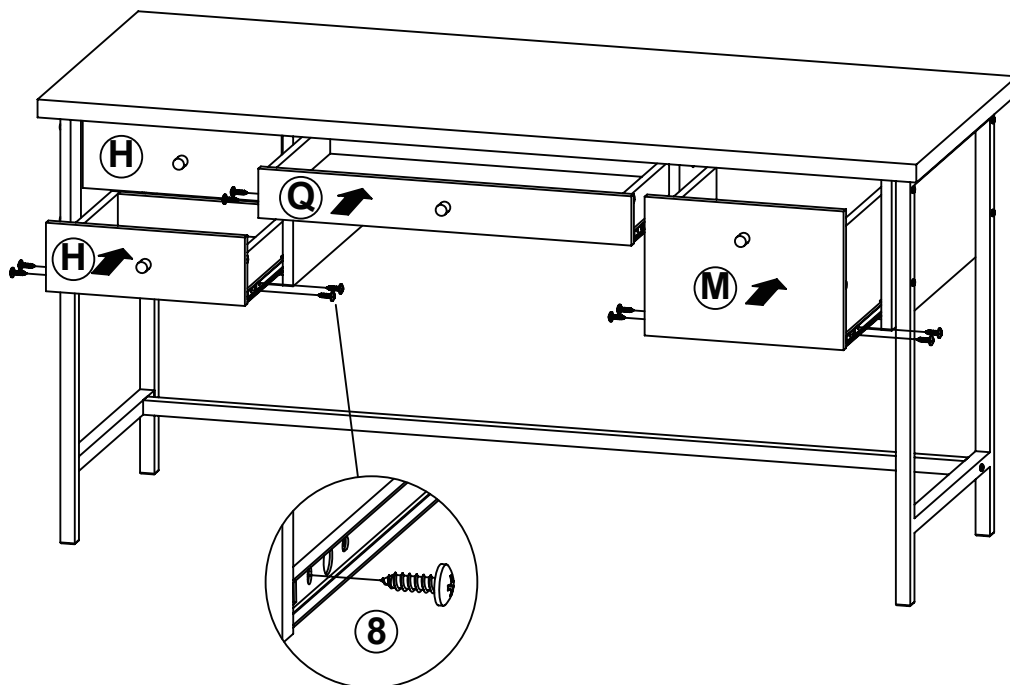
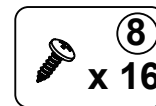

STEP 13
COMPLETE

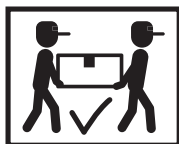
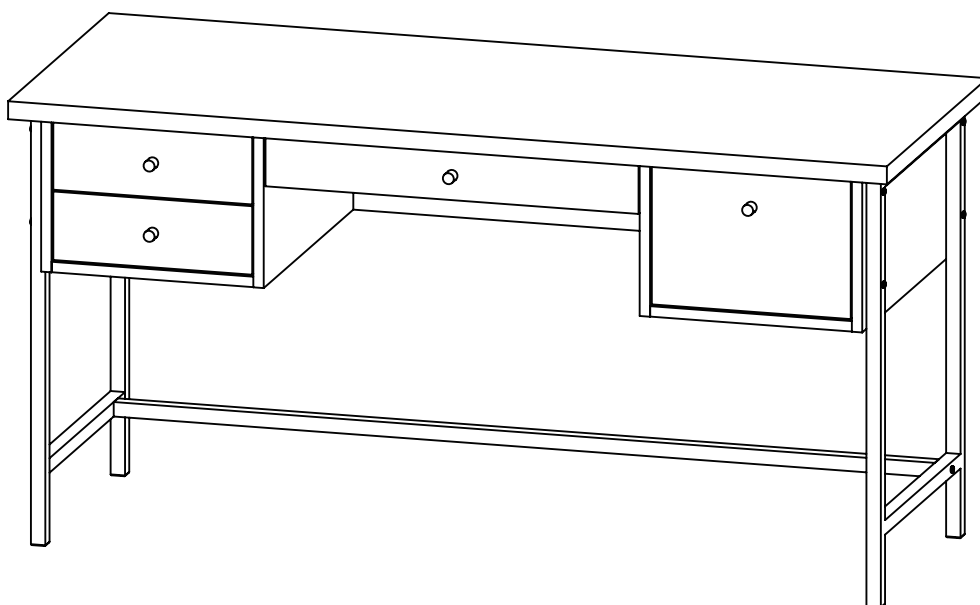

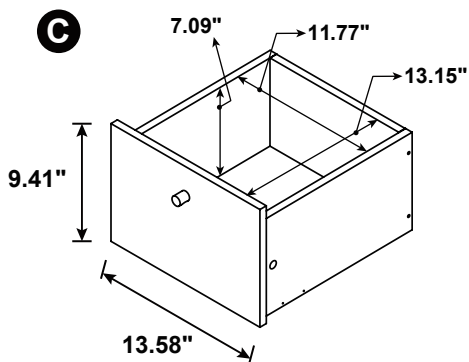
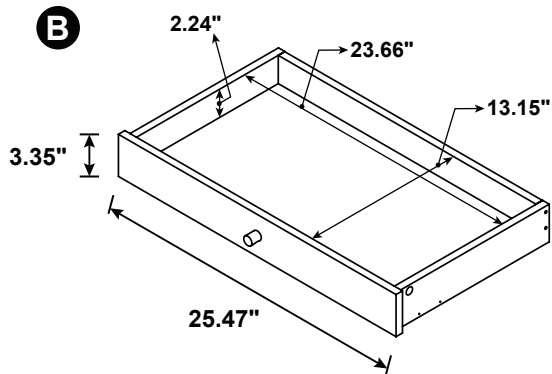
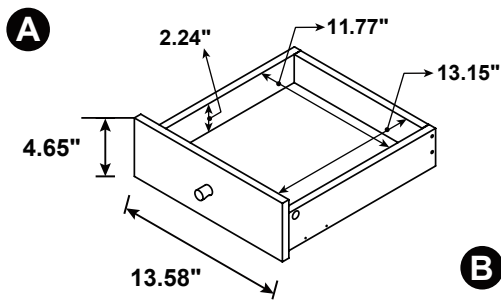
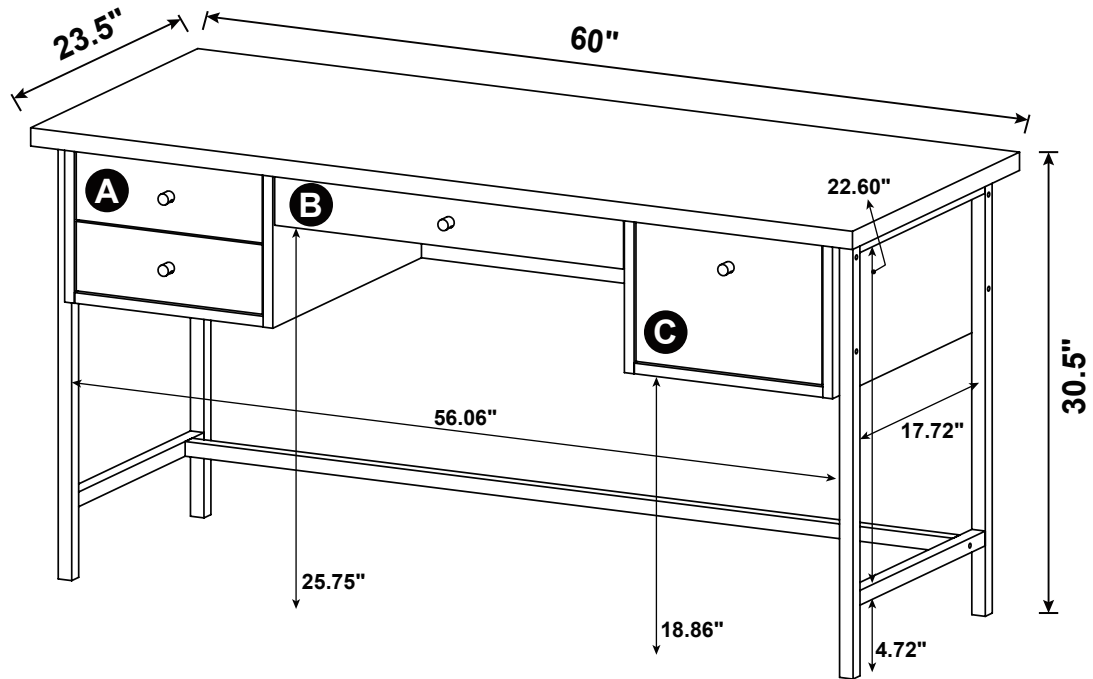

Note : Dimension tolerance $\pm 5\%$