

ASSEMBLY INSTRUCTIONS
COASTER FINE FURNITURE



Fine Furniture for every stage of life

801436
OFFICE CHAIR

REVISION 0 : 09/15/2017
REVISION 1 : 07/17/2019
REVISION 1 : 06/21/2022

ITEM: 801436



ASSEMBLY INSTRUCTIONS

ASSEMBLY TIPS:

1. Remove hardware from box and sort by size.
2. Please check to see that all hardware and parts are present prior to start of assembly.
3. Please follow attached instructions in the same sequence as numbered to assure fast & easy assembly.





WARNING!

1. Don't attempt to repair or modify parts that are broken or defective. Please contact the store immediately.
2. This product is for home use only and not intended for commercial establishments.

ASSEMBLY TIME 40 MINUTES

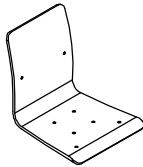
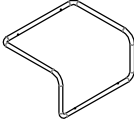
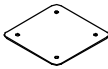
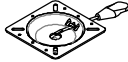
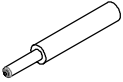
PARTS IDENTIFICATION

A	SEAT AND BACK		1PC
B	CHAIR FRAME		1PC
C	SEAT PLATE		1PC
D	ADJUSTING PLATE		1PC
E	GAS CYLINDER		1PC
F	COVER		1PC

ITEM:801436



ASSEMBLY INSTRUCTIONS

PARTS IDENTIFICATION

G	BASE		1PC
---	------	---	-----

H	CASTER		5PCS
---	--------	---	------

HARDWARE IDENTIFICATION

1	SHORT BOLT (1/4" x 12mm SR)		4PCS
---	--------------------------------	--	------

2	LONG BOLT (1/4" x 25mm SR)		4PCS
---	-------------------------------	---	------

3	NUT (1/4")		8PCS
---	---------------	---	------

4	SPRING WASHER (1/4")		8PCS
---	-------------------------	---	------

5	WASHER (ϕ 16mm SR)		8PCS
---	-----------------------------	---	------

6	ALLEN WRENCH (4mm)		1PC
---	-----------------------	---	-----

ITEM: 801436



ASSEMBLY INSTRUCTIONS

STEP 1

Do not tighten until each step is completed or instructed.

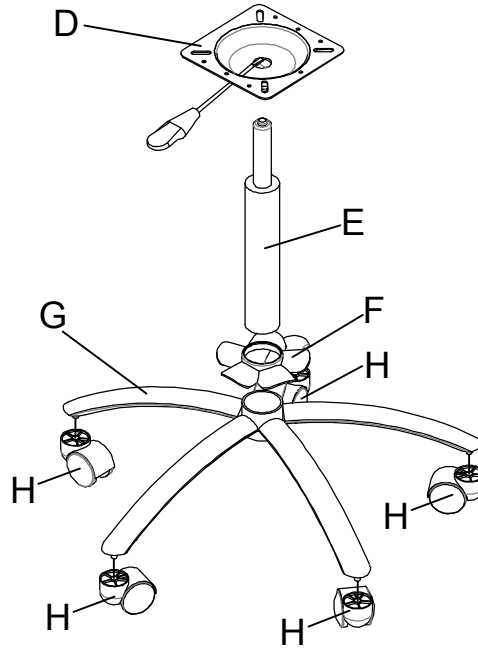

STEP 2

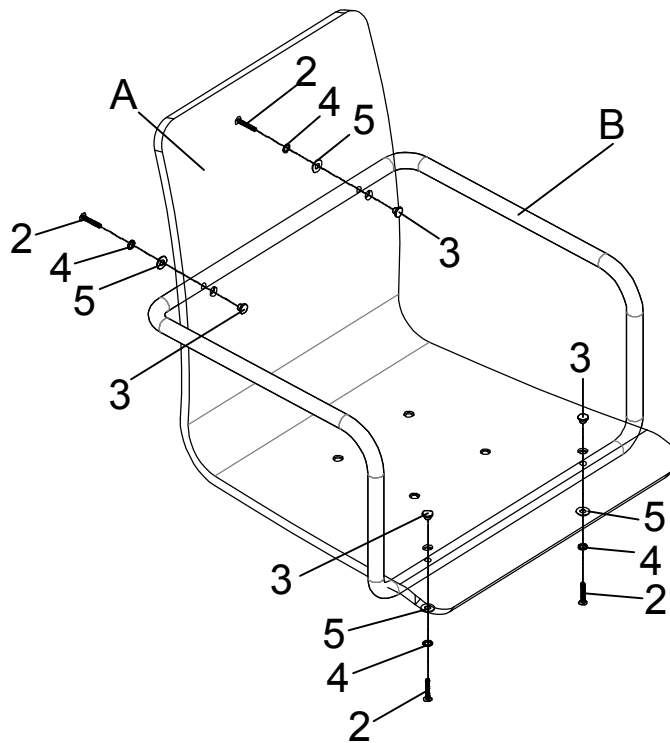

ITEM: 801436

ASSEMBLY INSTRUCTIONS

STEP 3

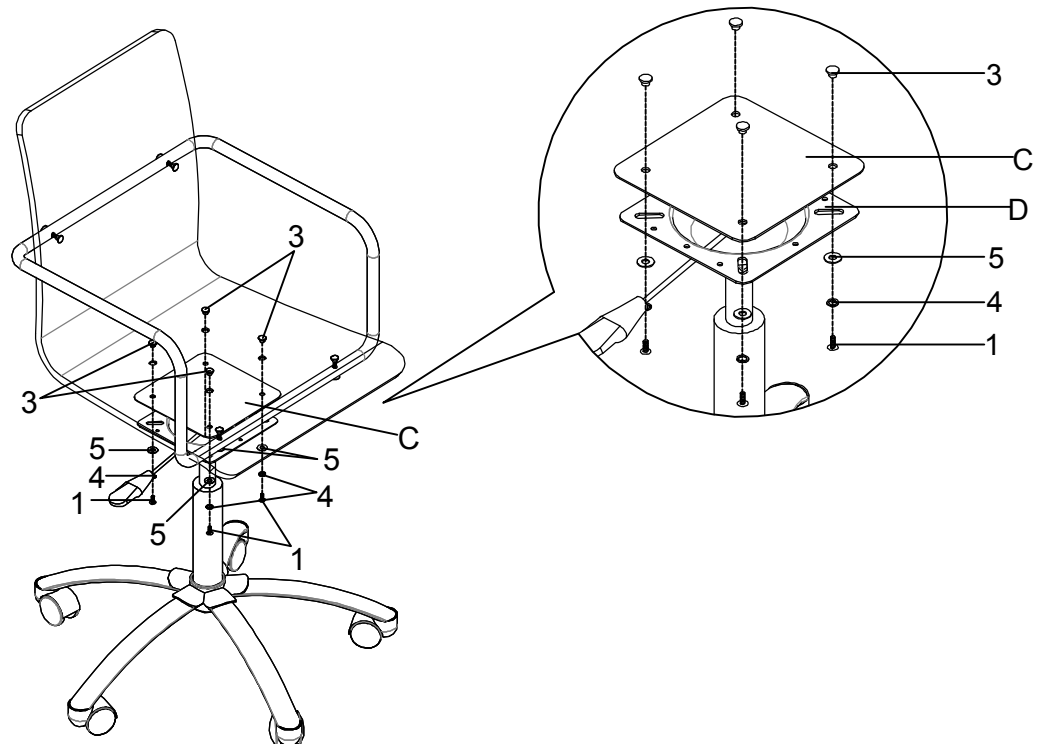

STEP 4 COMPLETE

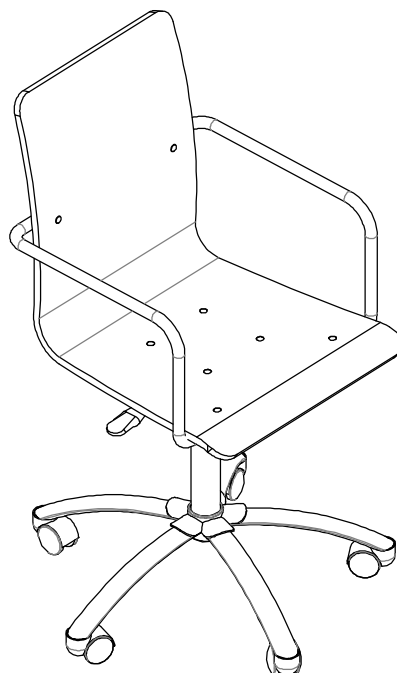

How to clean Acrylic product:
Using a dry soft microfiber cloth, lightly brush off any dust.
For additional care, dampen the cloth with warm water.
For deepest cleaning, use an Acrylic cleaner.

ITEM:801436 ASSEMBLY INSTRUCTIONS



Product Size : 597 X 597 X 883 H (MM)
Product Size : 23 1/2" X 23 1/2" X 34 3/4"

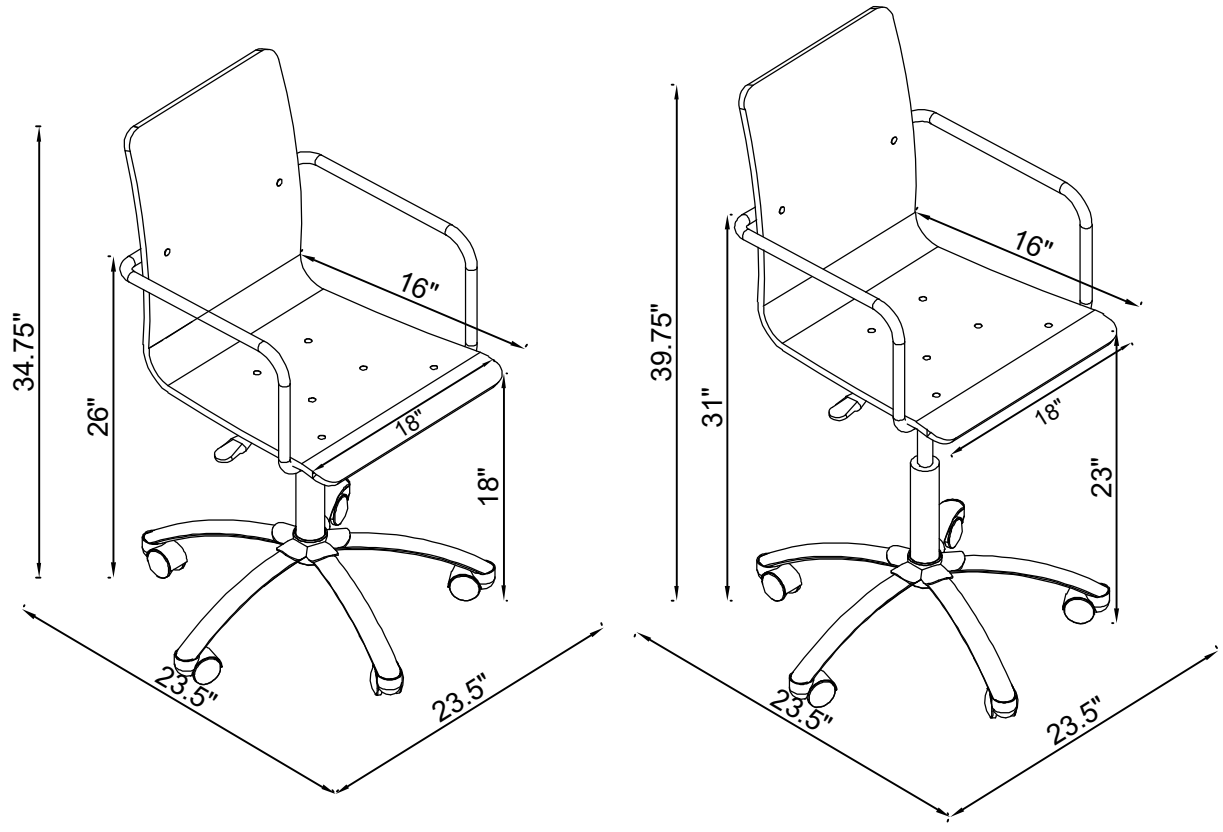

Note : Dimension tolerance $\pm 5\%$