

ASSEMBLY INSTRUCTIONS
COASTER FINE FURNITURE



Fine Furniture for every stage of life

801522
CREDENZA

ITEM:801522

ASSEMBLY INSTRUCTIONS

ASSEMBLY TIPS:

1. Remove hardware from box and sort by size.
2. Please check to see that all hardware and parts are present prior to start of assembly.
3. Please follow attached instructions in the same sequence as numbered to assure fast & easy assembly.



WARNING!







1. Don't attempt to repair or modify parts that are broken or defective. Please contact the store immediately.
2. This product is for home use only and not intended for commercial establishments.

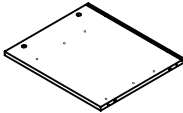
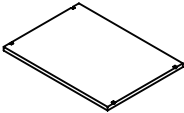
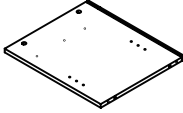
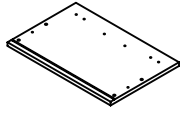
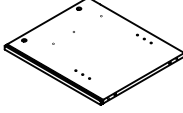
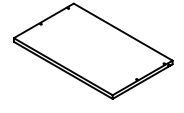
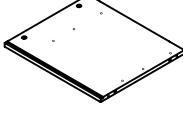

ASSEMBLY TIME

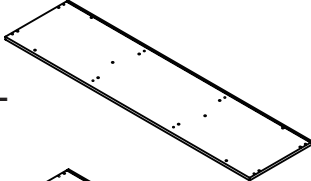
120 MINUTES

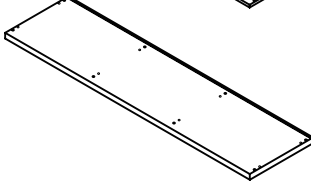
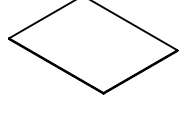
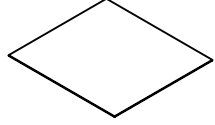
PARTS IDENTIFICATION

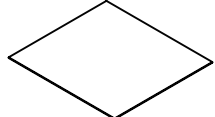
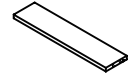
A	LEFT SIDE PANEL		1 PC	I	ADJUSTABLE SHELF		1 PC
B	LEFT DIVIDER PANEL		1 PC	J	LARGE DRAWER FRONT PANEL		2 PCS
C	RIGHT DIVIDER PANEL		1 PC	K	LARGE DRAWER BACK PANEL		2 PCS
D	RIGHT SIDE PANEL		1 PC	L	LARGE LEFT DRAWER SIDE PANEL		2 PCS
E	BOTTOM PANEL		1 PC	M	LARGE RIGHT DRAWER SIDE PANEL		2 PCS
F	TOP PANEL		1 PC	N	DRAWER BOTTOM PANEL		5 PCS
G	MIDDLE BACK PANEL		1 PC	O	SMALL DRAWER FRONT PANEL		3 PCS
H	BACK PANEL		2 PCS	P	SMALL DRAWER BACK PANEL		3 PCS

NOTE:

Phillips head screw driver is required in the assembly process; however, manufacturer does not provide this item.

ITEM: 801522

Q SMALL LEFT
DRAWER SIDE
PANEL

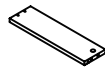

3 PCS

S CROSS BAR

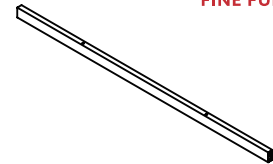

1 PC

R SMALL RIGHT
DRAWER SIDE
PANEL

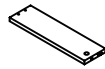

3 PCS



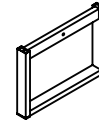







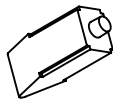
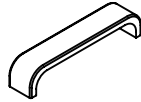

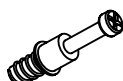

T FOOT

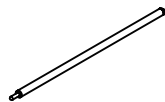

2 PCS

Z

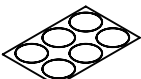
HARDWARE IDENTIFICATION

NO	DESCRIPTION	FIGURE	Q'TY	NO	DESCRIPTION	FIGURE	Q'TY
1	GLUE 40g		1 PC	10	HANDLE L=106mm		5 PCS
2	WOODEN DOWEL Ø 8x30mm		30 PCS	11	HANDLE BOLT Ø 4x23mm SR		10 PCS
3	CAM BOLT Ø 7x35.5mm SR		18 PCS	12	BOLT M 6x43mm SR		8 PCS
4	CAM LOCK Ø 15x12mm SR		18 PCS	13	ALLEN WRENCH 4mm SR		1 PC
5	LONG SCREW Ø 4.5x42mm SR		8 PCS	14	IRON BAR Ø 9.5x352mm SR		4 PCS
6	SCREW Ø 4.3x35mm SR		20 PCS	15	FIXER		4 PCS
7	PIN Ø 4.9x8mm SR		4 PCS	16	FIXER SCREW Ø 3x19mm SR		4 PCS
8	GLIDES L = 350mm WHT		5 SET	17	STICKER Ø 20mm		3 PCS
9	SHORT SCREW Ø 3x10mm SR		60 PCS				

Z8,Z10,Z14 not included in blister packaging.

NOTE:

Phillips head screw driver is required in the assembly process; however, manufacturer does not provide this item.

STEP 1

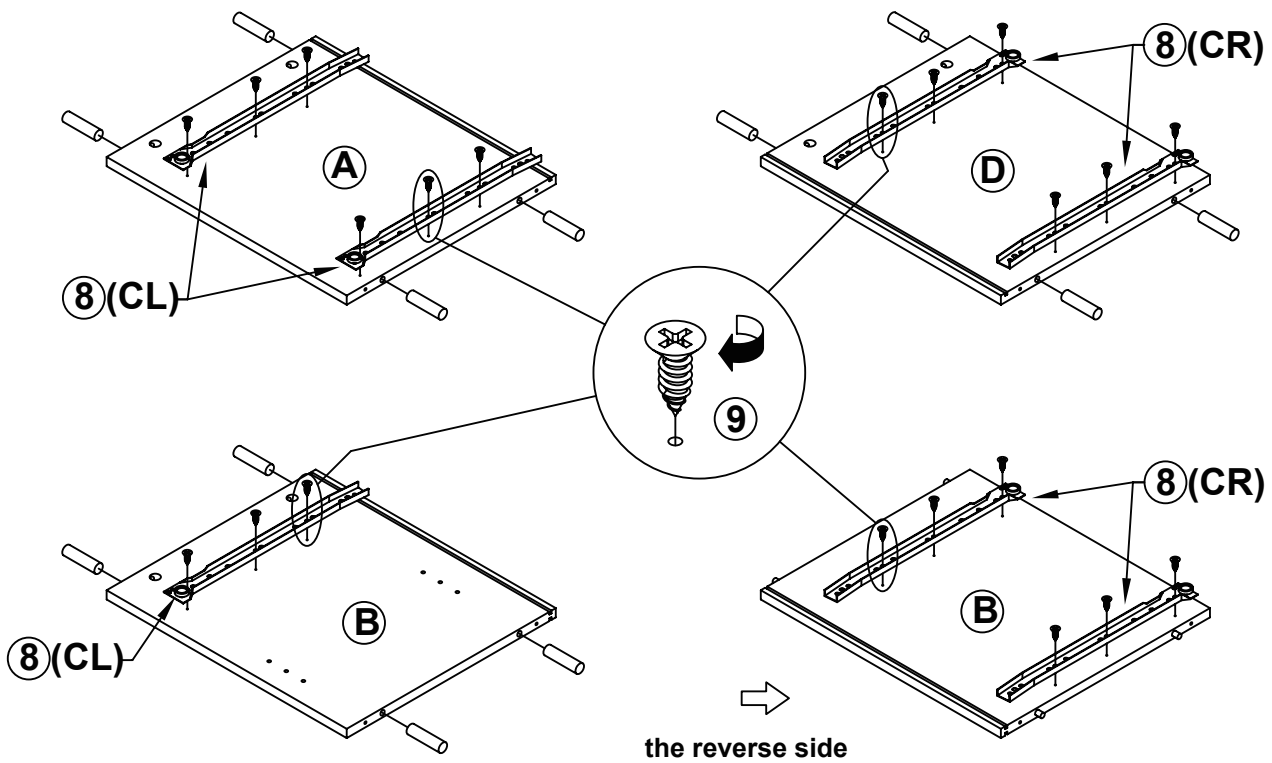
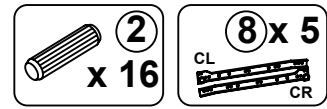

the reverse side

the reverse side

INCORRECT
CORRECT

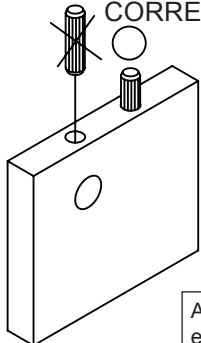

Apply glue on all wooden dowels to ensure integrity of the structure.

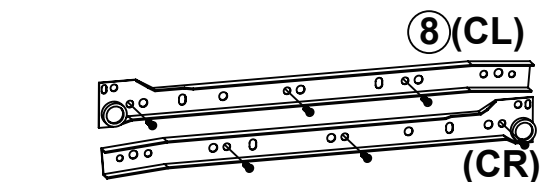
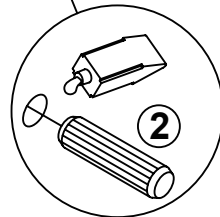

ITEM: **801522**

COASTER
FINE FURNITURE

STEP 2

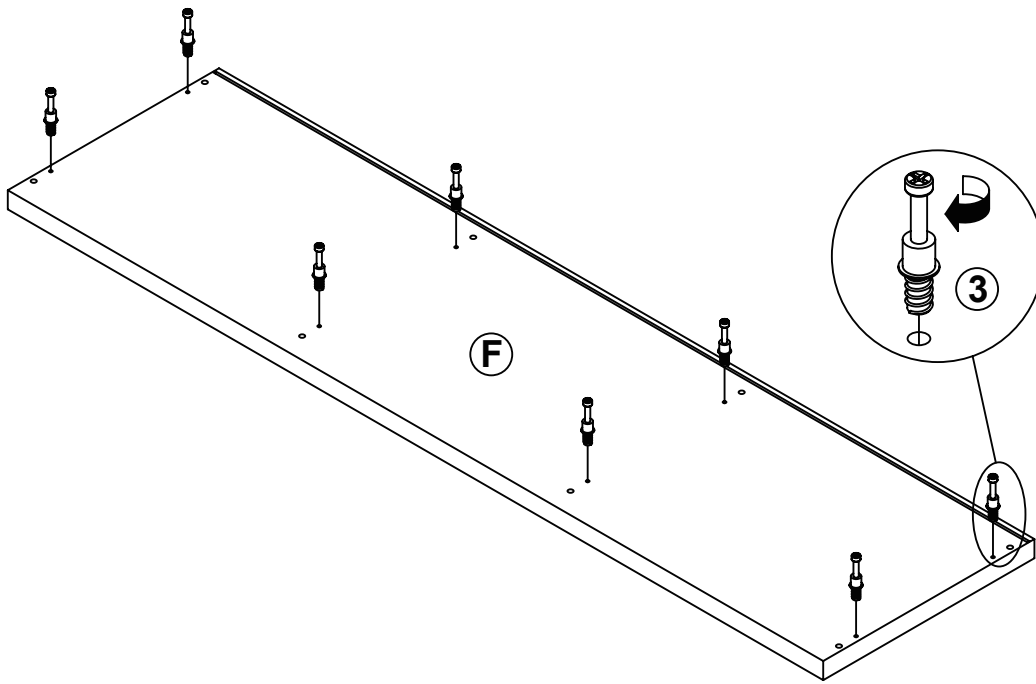
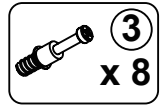

STEP 3

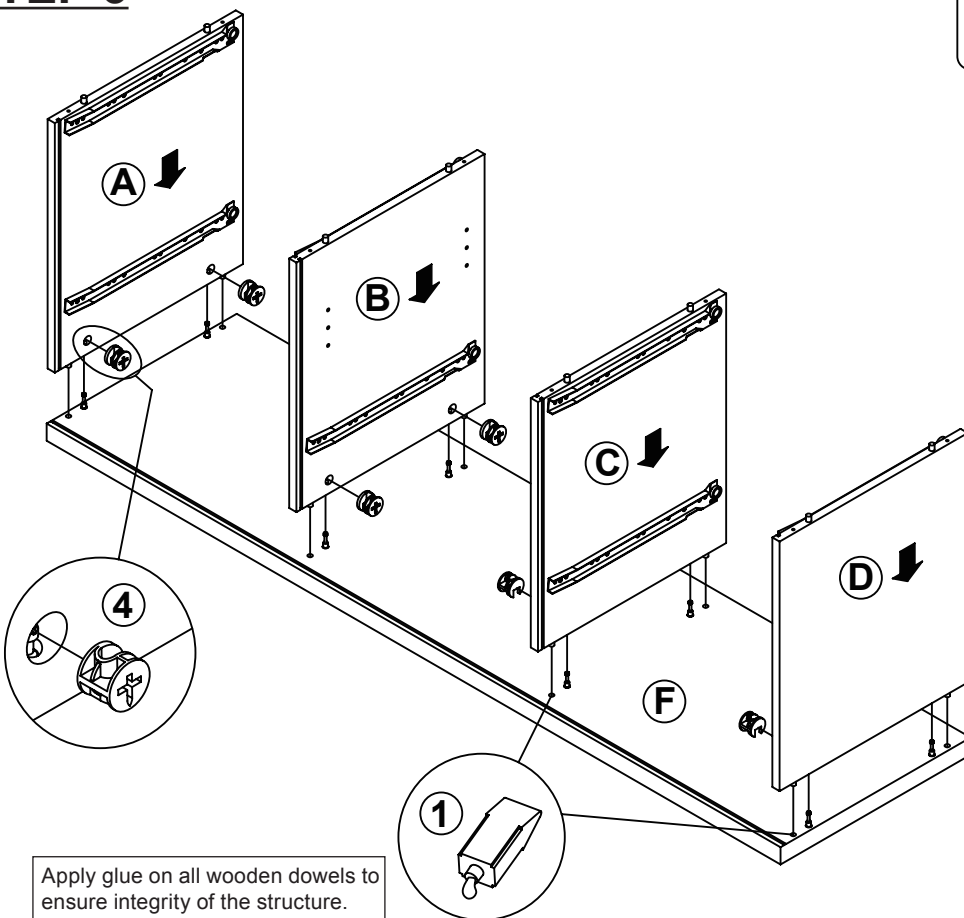
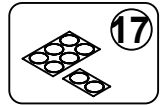
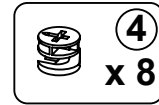

Apply glue on all wooden dowels to ensure integrity of the structure.

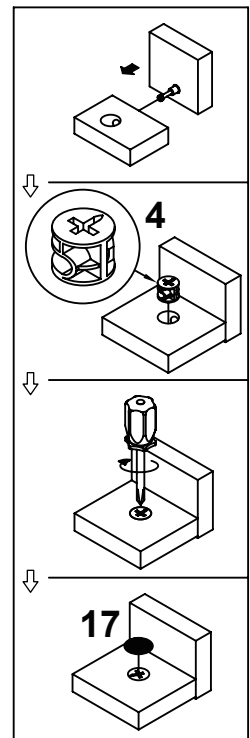

ITEM: 801522

STEP 4

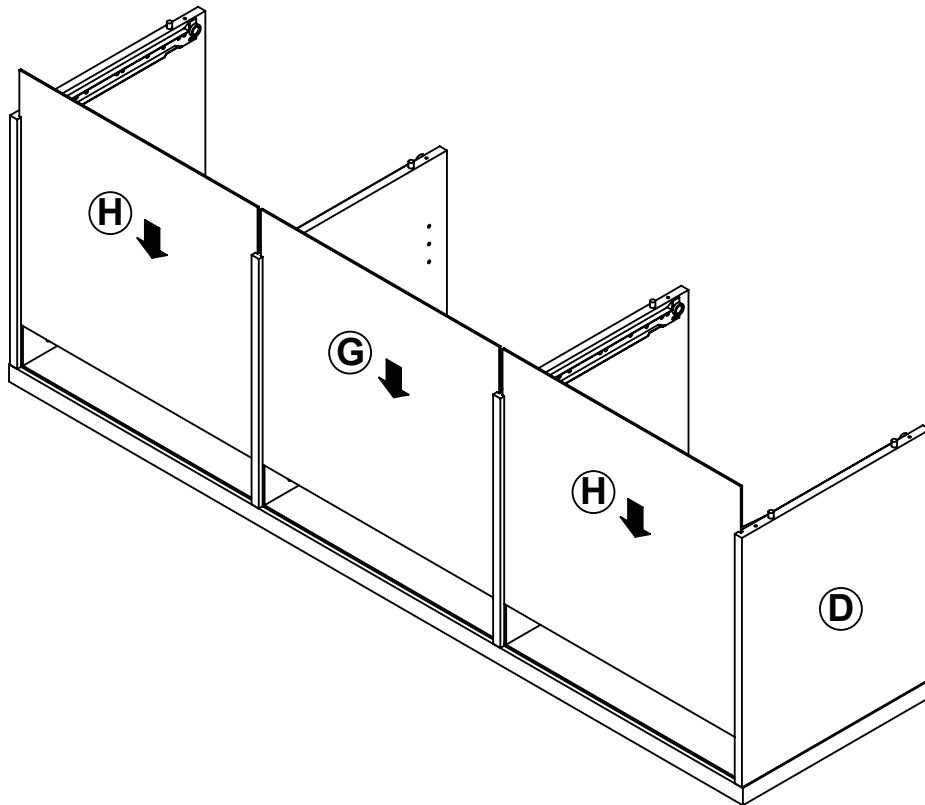

STEP 5

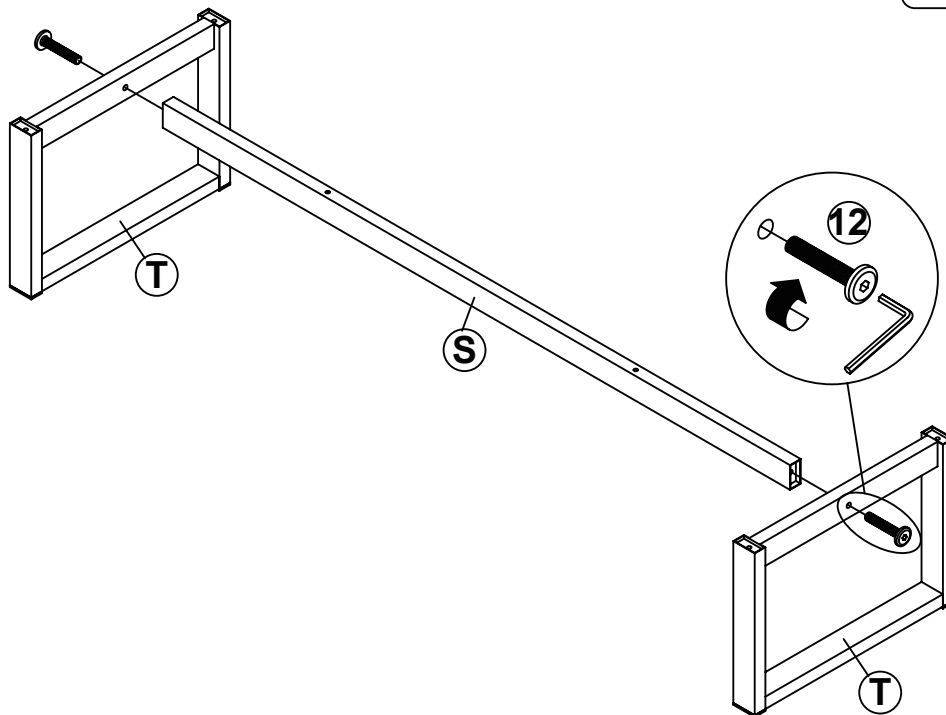

ITEM: 801522

COASTER
FINE FURNITURE

STEP 6

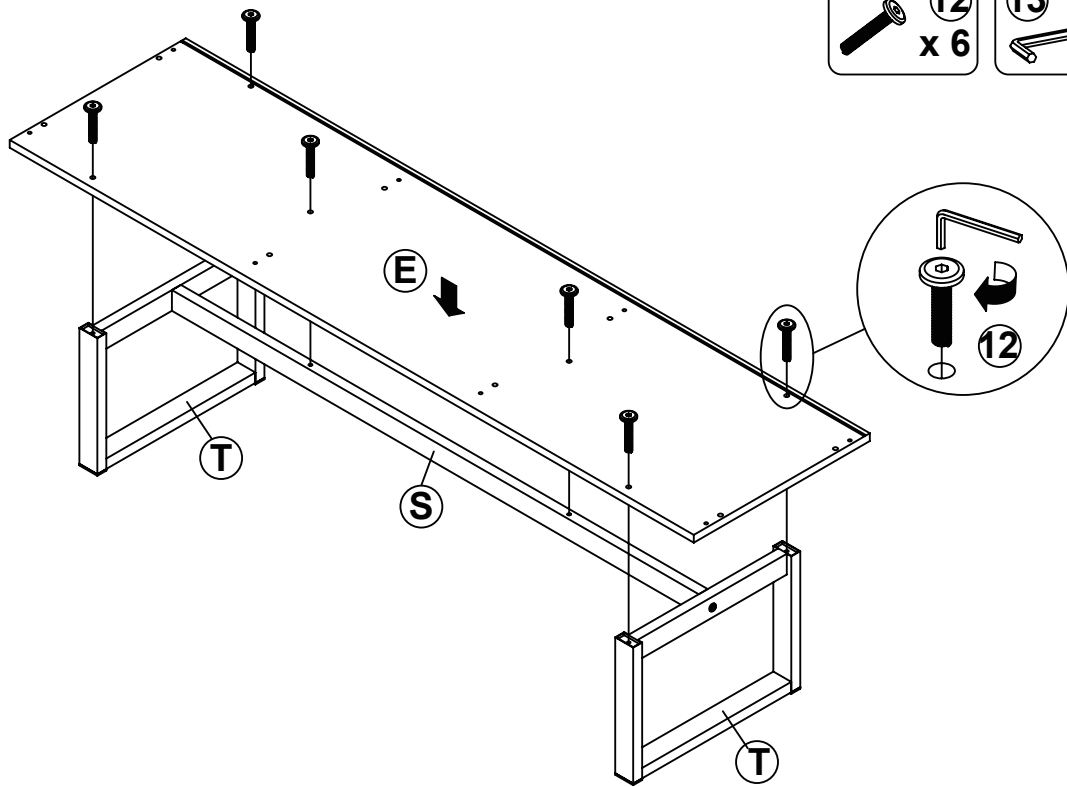

STEP 7

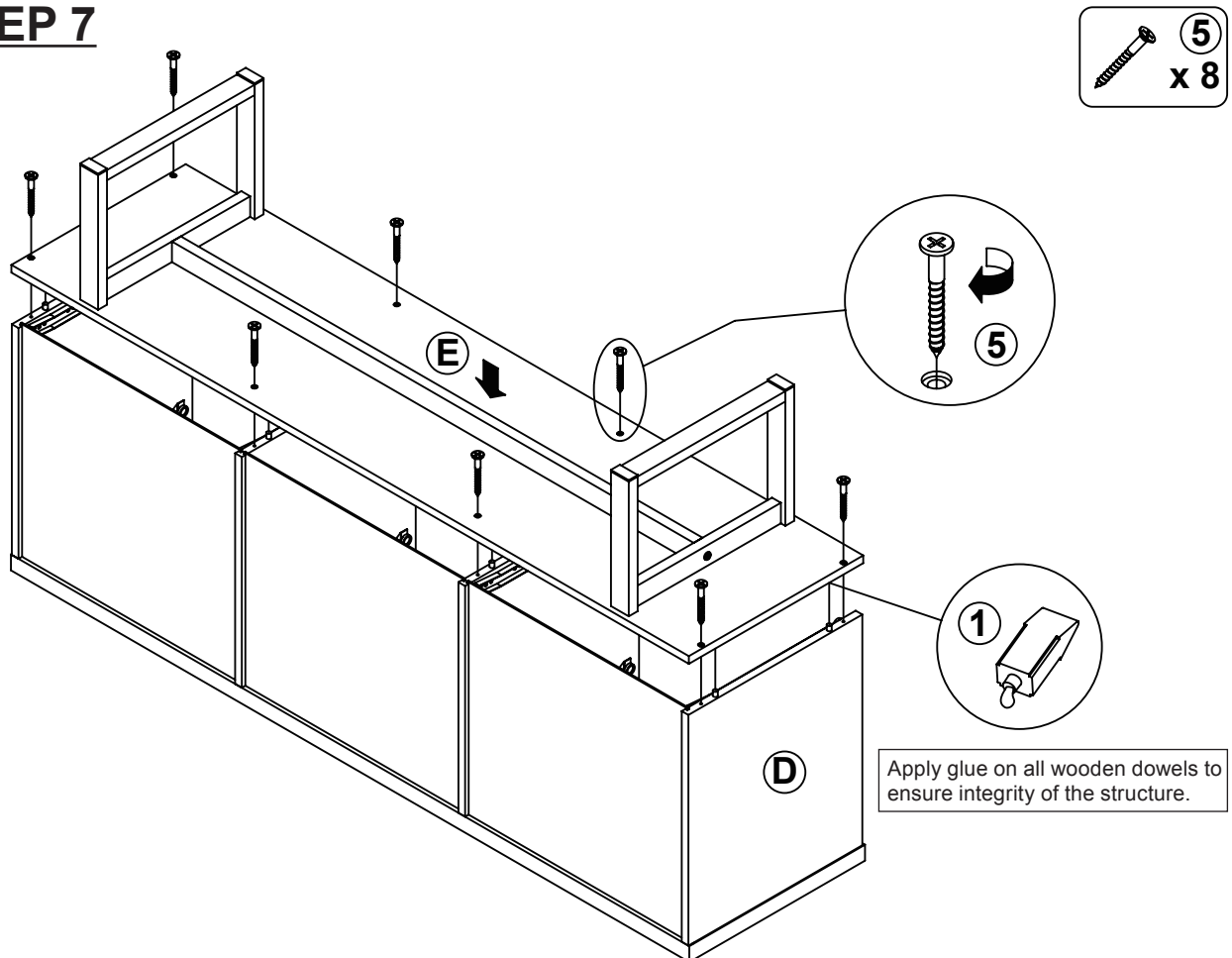

Apply glue on all wooden dowels to ensure integrity of the structure.

STEP 8

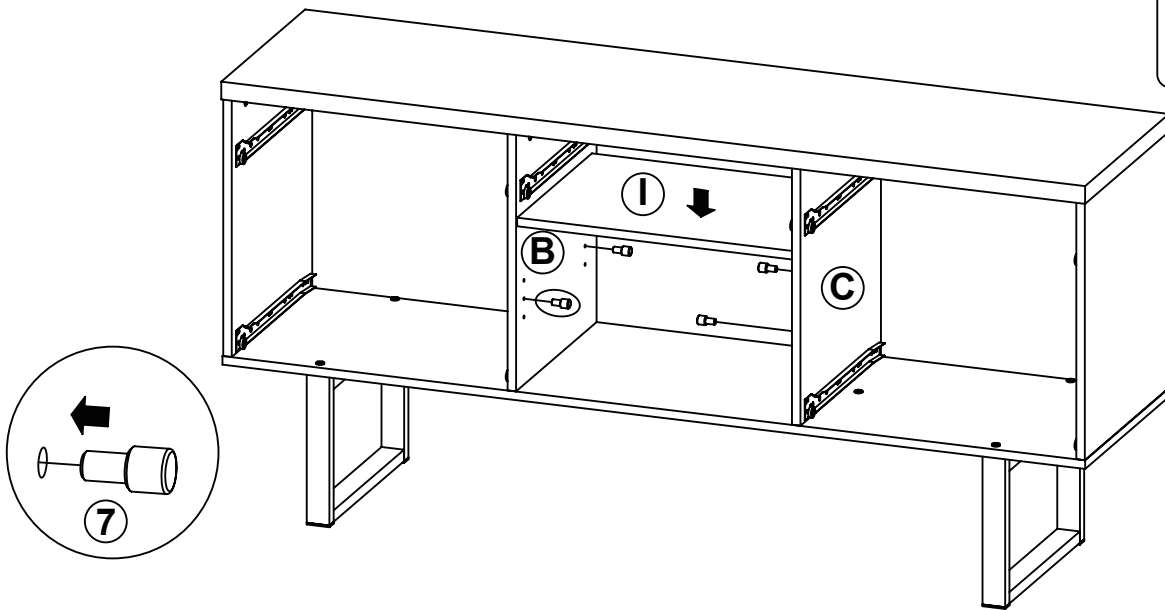
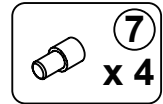

STEP 9

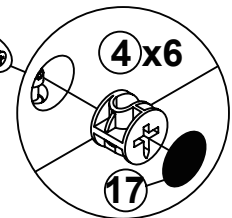
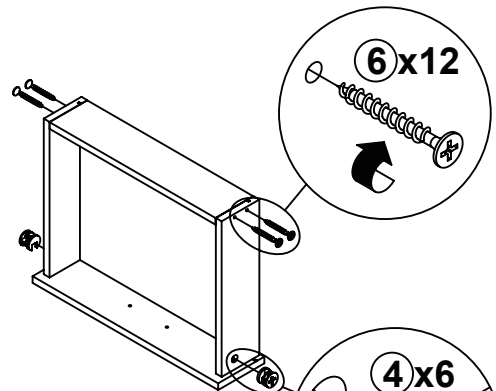
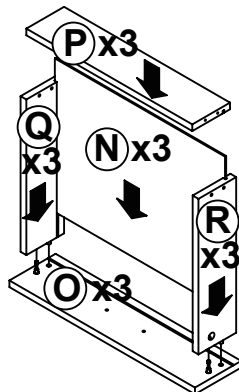
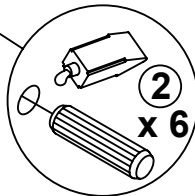
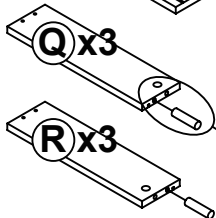
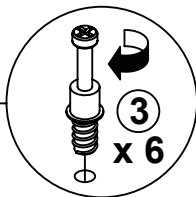
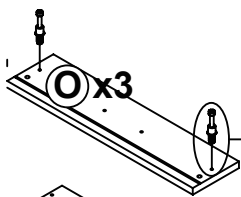

Apply glue on all wooden dowels to ensure integrity of the structure.

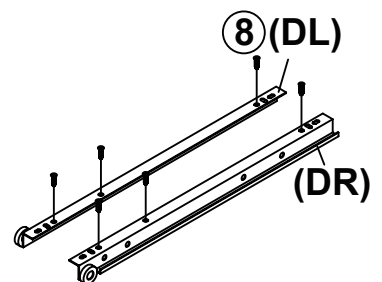
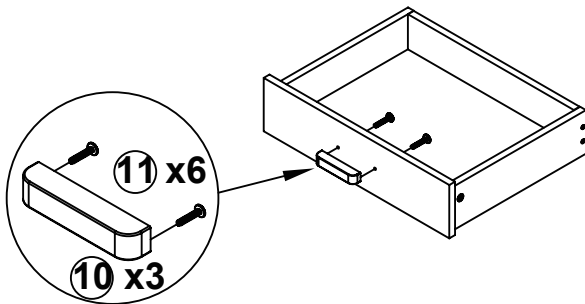
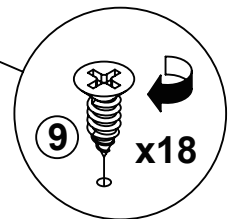
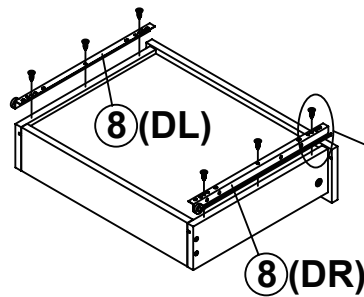

ITEM: 801522

STEP 10

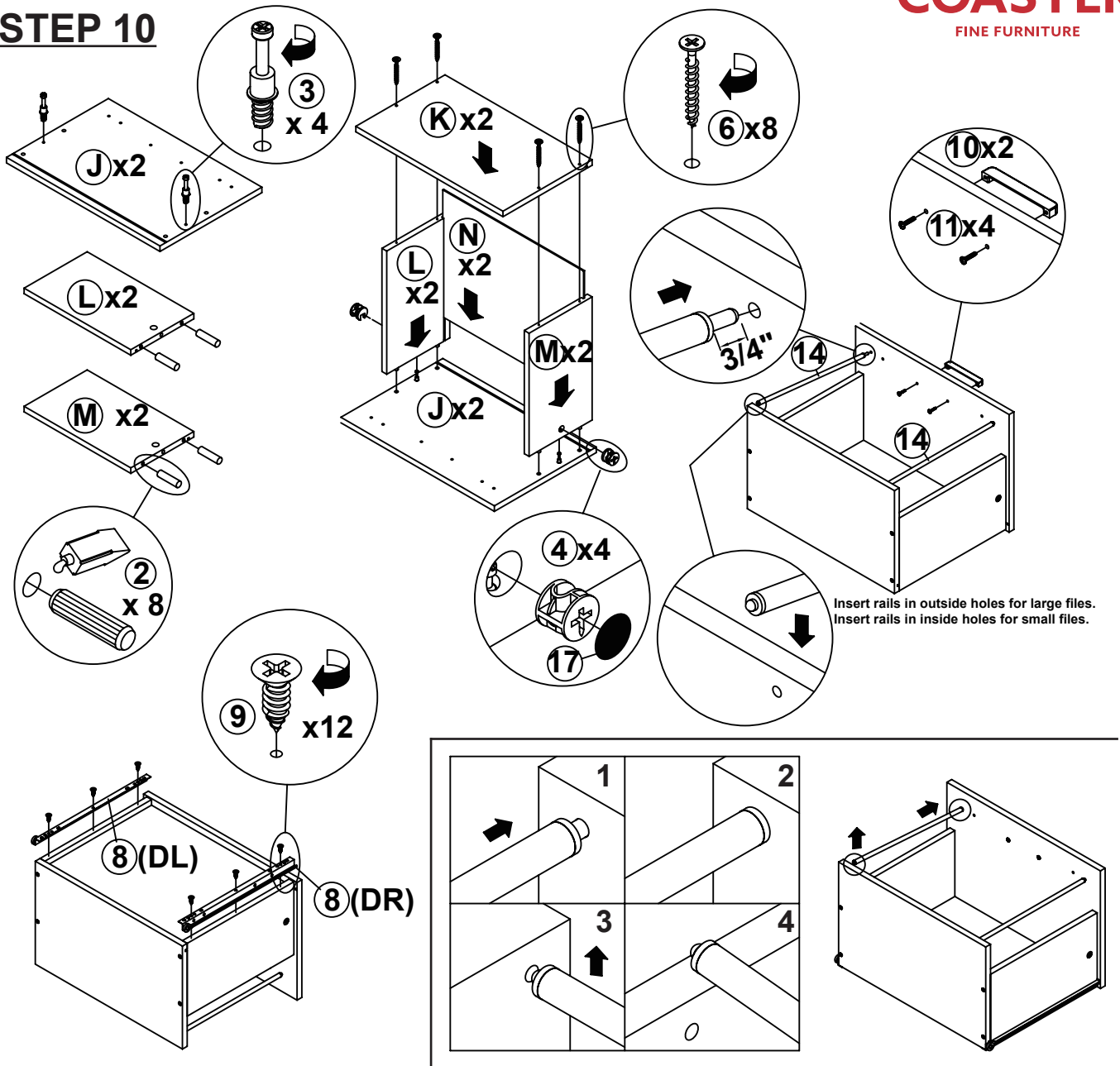

STEP 11

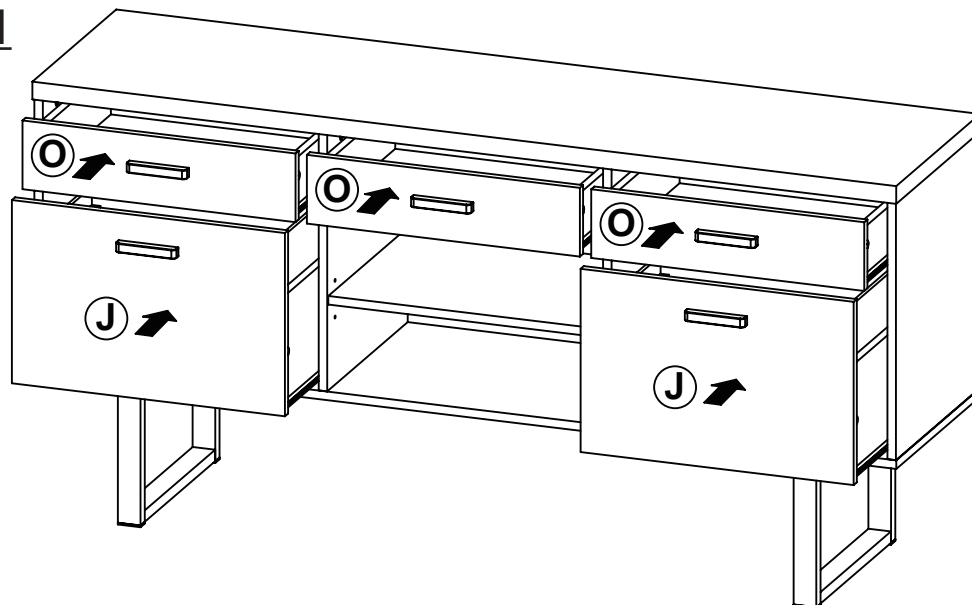

ITEM: 801522

STEP 12

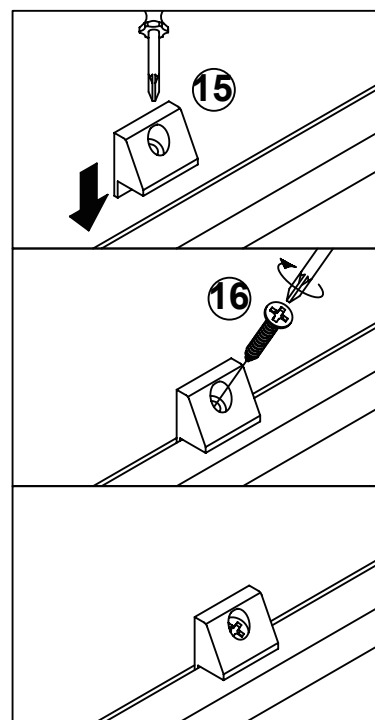
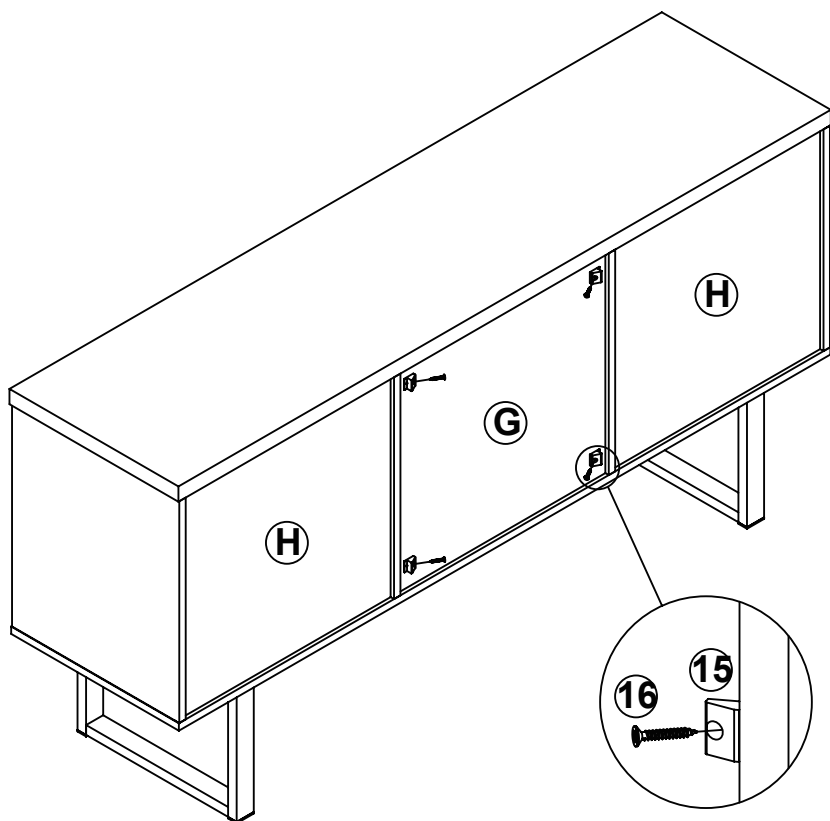

STEP 13

COMPLETE

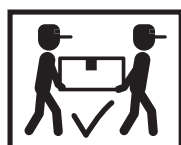
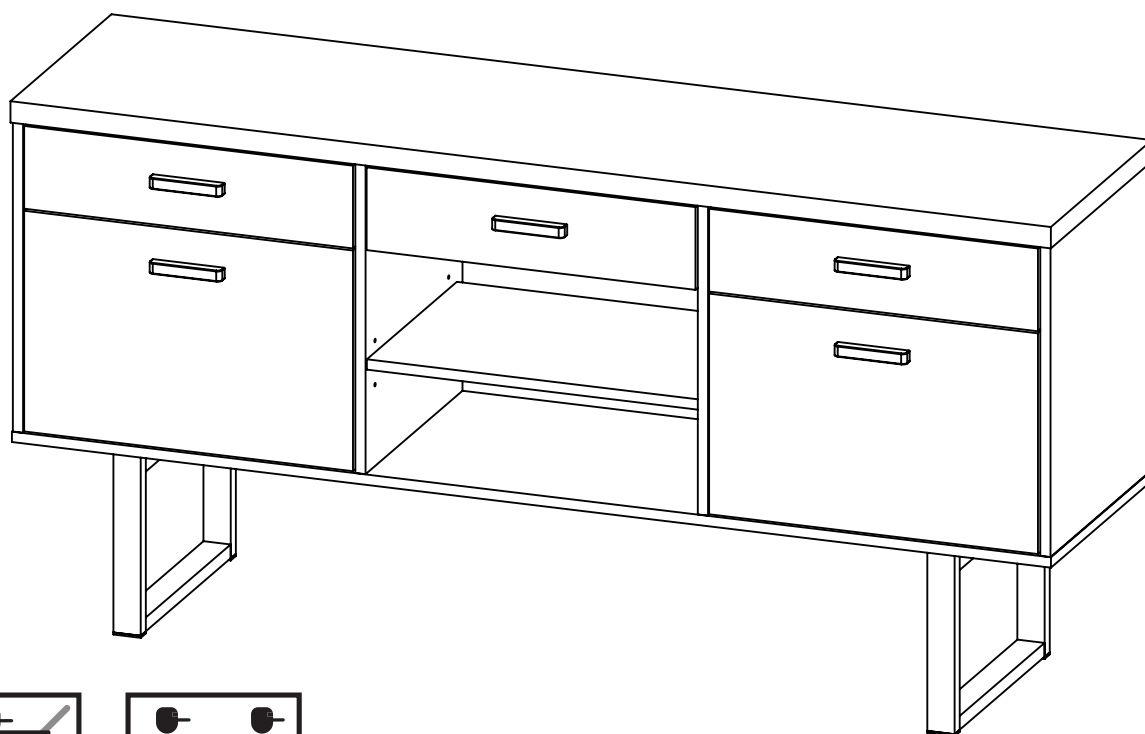

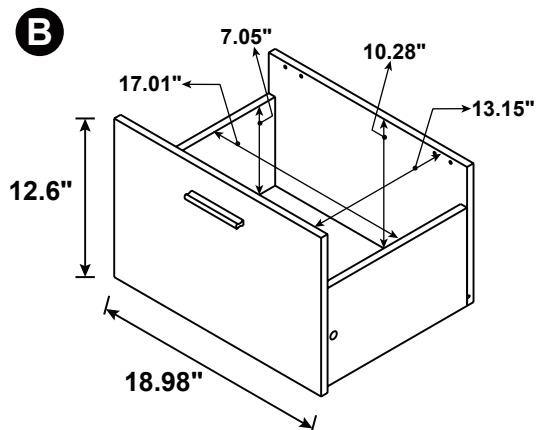
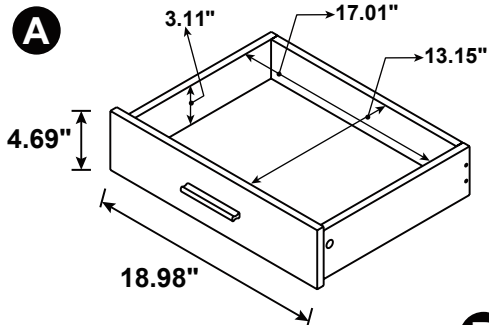
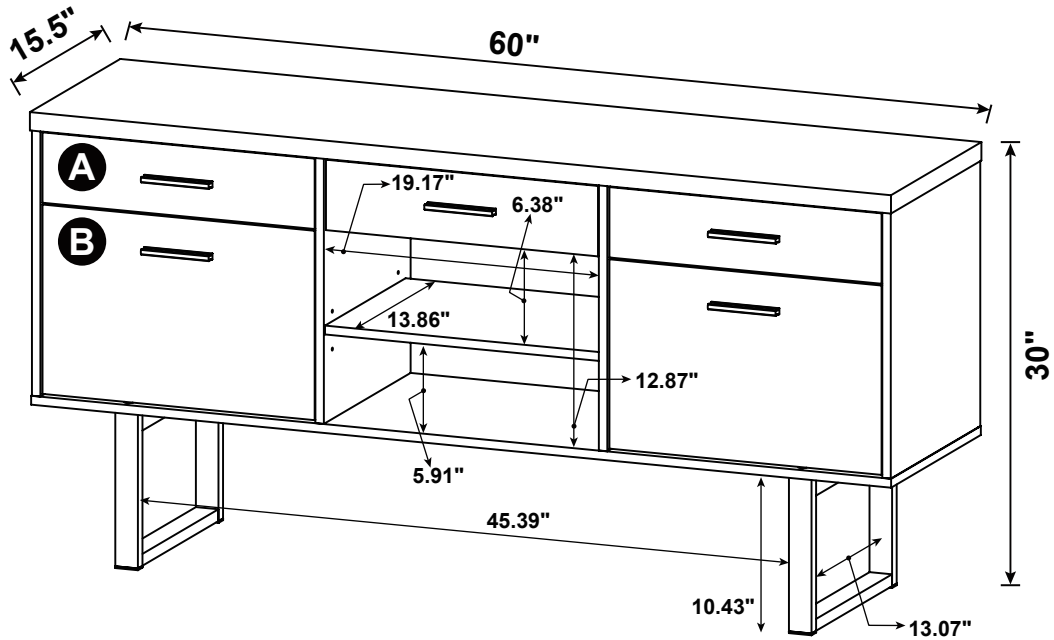

Note : Dimension tolerance $\pm 5\%$

ANTI-TIPPING INSTALLMENT INSTRUCTIONS

FURNITURE TIPPING RESTRAINT

WARNING

Injury may result from tipping furniture.
This restraint may protect against tipping furniture.
Do not allow children to climb on furniture.
This restraint is not a substitute for proper adult supervision.
Failure to detach this restraint before moving the furniture
may result in injury and damage.

1. To attach the anti-tip strap, securely mount one end to the top of the case piece with the 5/8" screw.
2. Position the case piece against the wall in the desired location.
3. Pull the anti-tip strap taut and mark the position of where you will secure the other end on the wall.
4. Drill a 1-1/4" hole in the spot you marked.
5. Tap in plastic wall plug.
6. Fasten anti-tip strap with wall screw provided.

(Please install the anti-tipping kit in the middle of the case piece if only have one set of anti-tipping kit.)

