

ASSEMBLY INSTRUCTIONS
COASTER FINE FURNITURE



Fine Furniture for every stage of life

801535
WRITING DESK

REVISION 0 : 09/15/2017
REVISION 1 : 07/17/2019
REVISION 2 : 06/21/2022

ITEM: 801535



ASSEMBLY INSTRUCTIONS

ASSEMBLY TIPS:

1. Remove hardware from box and sort by size.
2. Please check to see that all hardware and parts are present prior to start of assembly.
3. Please follow attached instructions in the same sequence as numbered to assure fast & easy assembly.



WARNING!

1. Don't attempt to repair or modify parts that are broken or defective. Please contact the store immediately.
2. This product is for home use only and not intended for commercial establishments.

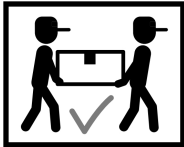

ASSEMBLY TIME 30 MINUTES

PARTS IDENTIFICATION

B1: TOP

A TOP GLASS

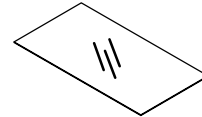

1PC

B2: BASE

B LEFT LEG



4PCS

C RIGHT LEG



4PCS

D SUPPORT CROSSBAR

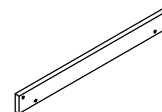

2PCS

HARDWARE IDENTIFICATION

1 BOLT
(1/4" x 50mm SR)



8PCS

4 FLOOR PROTECTOR
(ϕ 10x1mm)



8PCS

2 NUT
(1/4" SR)



8PCS

5 COVER
(ϕ 11mm SR)



8PCS

3 SUCTION CUP
(ϕ 20x5mm)



4PCS

6 ALLEN WRENCH
(4mm)



1PC

Hardware pack is located in 801535B2

ITEM: 801535

ASSEMBLY INSTRUCTIONS

STEP 1

Do not tighten until each step is completed or instructed.

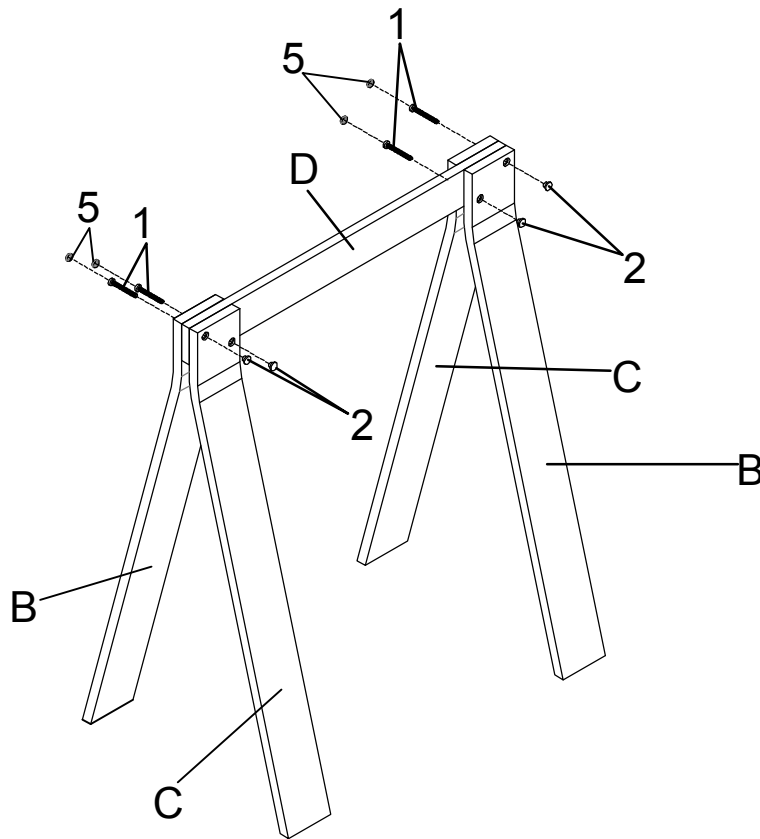

To assemble the two base as the same way.

ITEM: 801535

ASSEMBLY INSTRUCTIONS

STEP 2

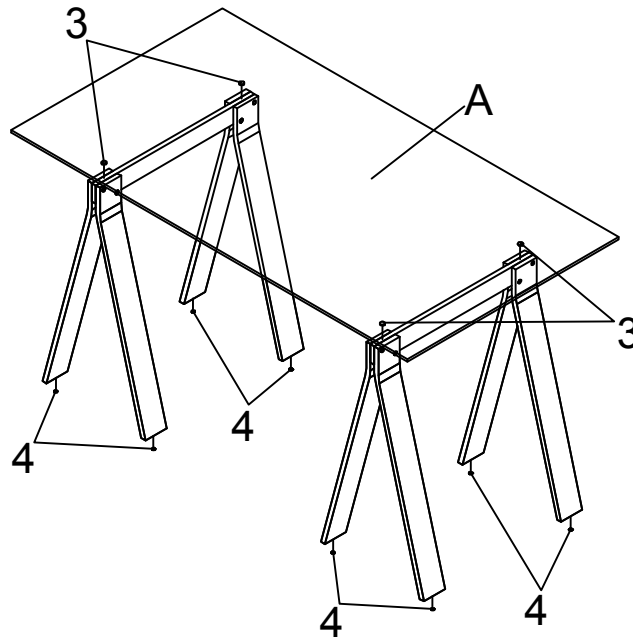

STEP 3 COMPLETE

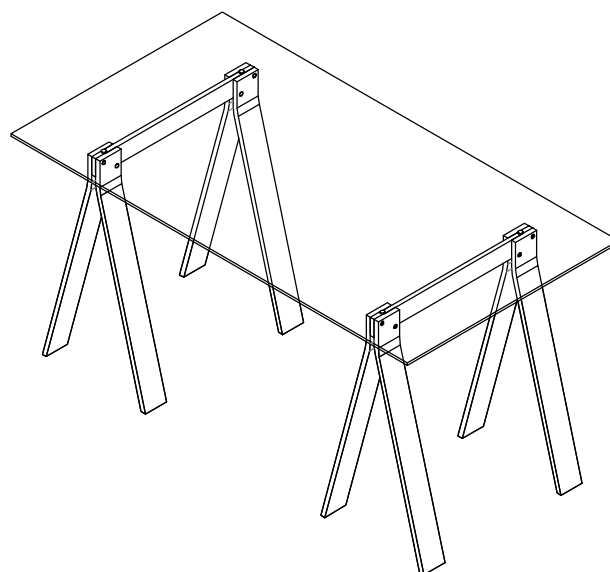

How to clean Acrylic product:
Using a dry soft microfiber cloth, lightly brush off any dust.
For additional care, dampen the cloth with warm water.
For deepest cleaning, use an Acrylic cleaner.

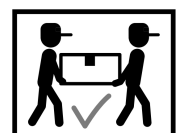

ITEM:801535 ASSEMBLY INSTRUCTIONS



| |
|---|
| Product Size : 1500 X 800 X 762 H (MM) |
| Product Size : 59" X 31 1/2" X 30" |

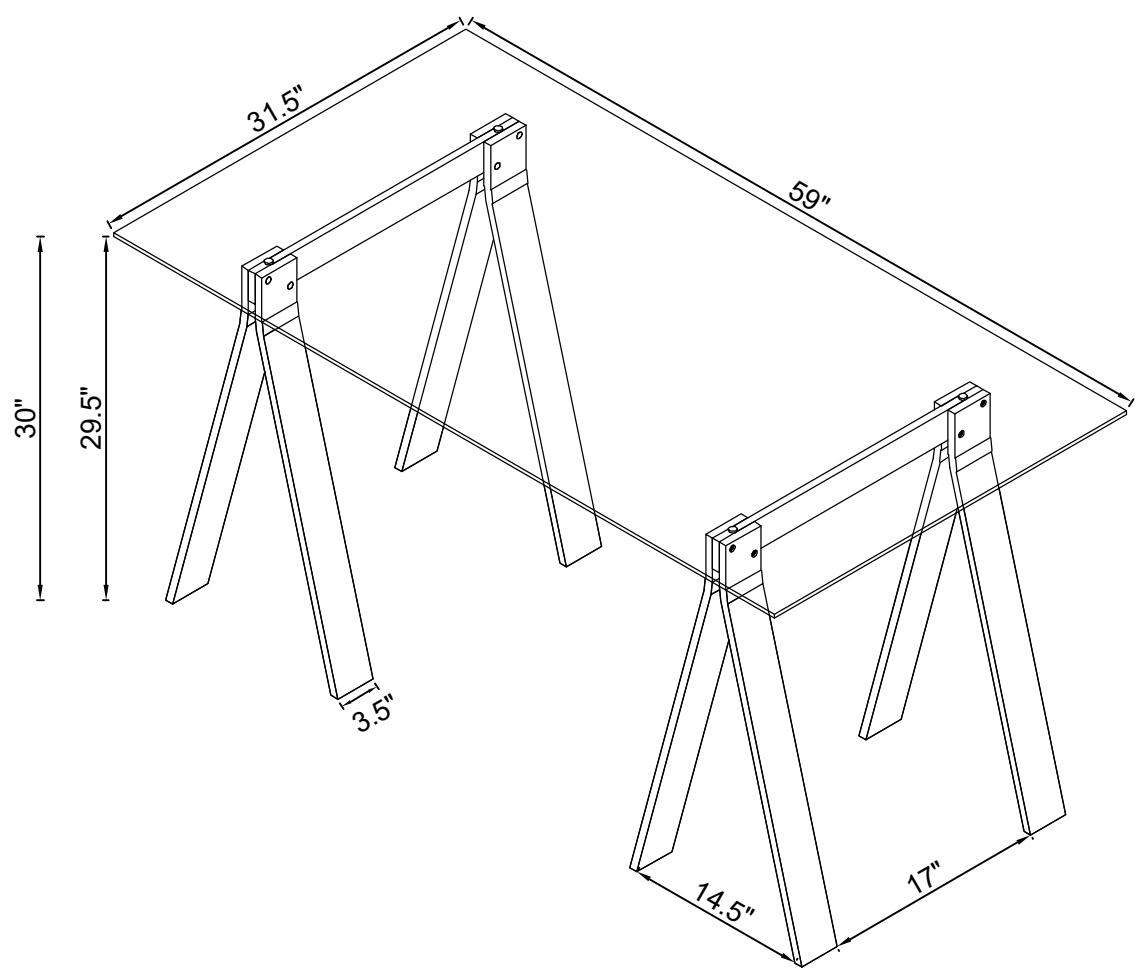

Note : Dimension tolerance $\pm 5\%$