

ASSEMBLY INSTRUCTIONS
COASTER FINE FURNITURE



Fine Furniture for every stage of life

803521
OFFICE DESK

ITEM:803521

ASSEMBLY INSTRUCTIONS

ASSEMBLY TIPS:

1. Remove hardware from box and sort by size.
2. Please check to see that all hardware and parts are present prior to start of assembly.
3. Please follow attached instructions in the same sequence as numbered to assure fast & easy assembly.



WARNING!

1. Don't attempt to repair or modify parts that are broken or defective. Please contact the store immediately.
2. This product is for home use only and not intended for commercial establishments.

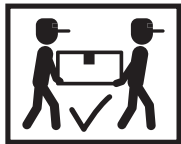

ASSEMBLY TIME

80 MINUTES

PARTS IDENTIFICATION

A	LEFT SIDE PANEL		1 PC	I	LARGE TOP PANEL		1 PC
B	LEFT DIVIDER PANEL		1 PC	J	SMALL DRAWER FRONT PANEL		1 PC
C	RIGHT DIVIDER PANEL		1 PC	K	SMALL DRAWER BACK PANEL		1 PC
D	RIGHT SIDE PANEL		1 PC	L	SMALL LEFT DRAWER SIDE PANEL		1 PC
E	BOTTOM PANEL		2 PCS	M	SMALL RIGHT DRAWER SIDE PANEL		1 PC
F	TOP PANEL		2 PCS	N	DRAWER BOTTOM PANEL		2 PCS
G	LEFT BACK PANEL		1 PC	O	LARGE DRAWER FRONT PANEL		1 PC
H	MIDDLE BACK PANEL		1 PC	P	LARGE DRAWER BACK PANEL		1 PC

NOTE:

Phillips head screw driver is required in the assembly process; however, manufacturer does not provide this item.

ITEM:803521

Q LARGE LEFT DRAWER SIDE PANEL 1 PC

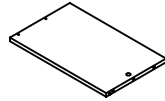

R LARGE RIGHT DRAWER SIDE PANEL 1 PC

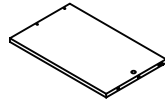

S DOOR 1 PC

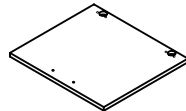

T CROSS BAR 2 PCS

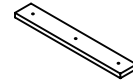



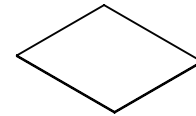



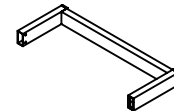



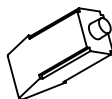
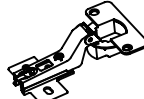
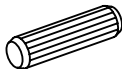

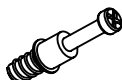

U RIGHT BACK PANEL 1 PC

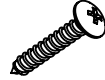
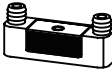

V FOOT 2 PCS

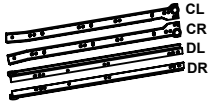
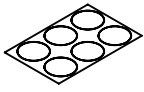

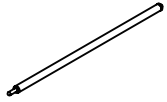
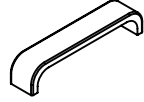
HARDWARE IDENTIFICATION

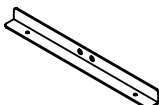
Z NO	DESCRIPTION	FIGURE	Q'TY	NO	DESCRIPTION	FIGURE	Q'TY
1	GLUE 40g		1 PC	12	HINGE (Ø 26mm SR)		2 PCS
2	WOODEN DOWEL Ø 8x30mm		30 PCS	13	HINGE SCREW (Ø 4x15mm SR)		8 PCS
3	CAM BOLT (Ø 7x35.5mm SR)		16 PCS	14	LONG BOLT (M6x35mm SR)		6 PCS
4	CAM LOCK (Ø 15x12mm SR)		16 PCS	15	BOLT (M6x28mm SR)		4 PCS
5	LONG SCREW (Ø 4.5x42mm SR)		12 PCS	16	SHORT BOLT (M6x15mm SR)		4 PCS
6	SCREW (Ø 4.3x35mm SR)		8 PCS	17	CROSS BAR SCREW (Ø 4x25mm RBW)		6 PCS
7	DOOR CATCH		1 PC	18	ALLEN WRENCH (4mm SR)		1 PC
8	GLIDES (L = 450mm WHT)		2 SET	19	STICKER Ø 20mm		3 PCS
9	SHORT SCREW (Ø 3x12mm SR)		28 PCS	20	IRON BAR (Ø 9.5x359mm SR)		2 PCS
10	HANDLE L=106mm		3 PCS	21	IRON 80mm		4 PCS
11	HANDLE BOLT (Ø 4x23mm SR)		6 PCS	22	"L" SUPPORT IRON 300mm		2 PCS

Z8,Z10,Z12,Z20,Z21,Z22 not included in blister packaging.

ITEM: 803521

STEP 1

- 2 x 20
- 3 x 4
- 7 x 1
- 8 x 2 (CL, CR)
- 9 x 16

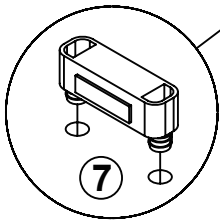
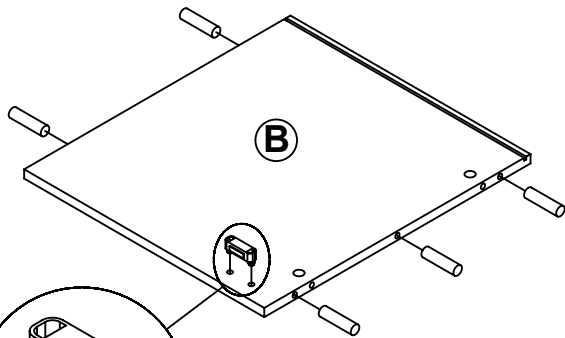
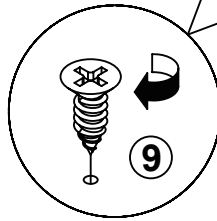
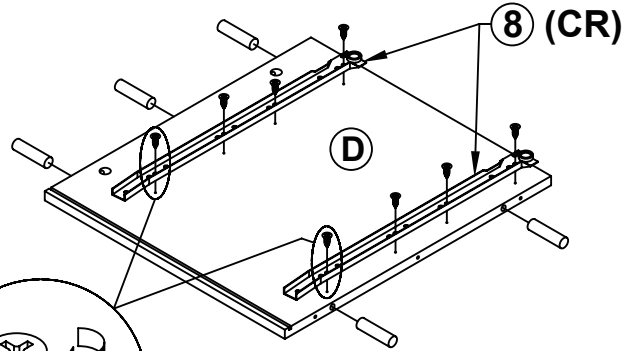
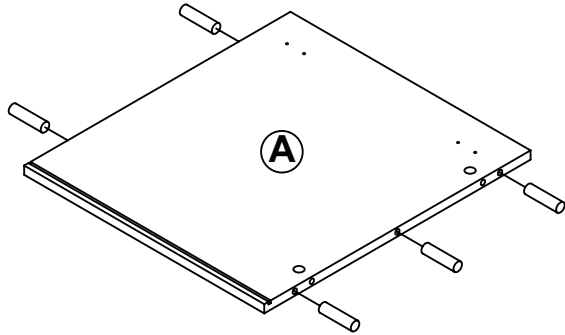

the reverse side

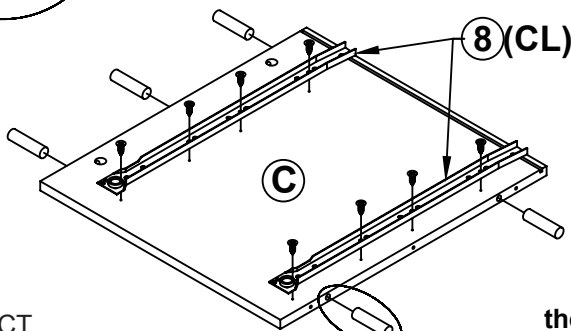
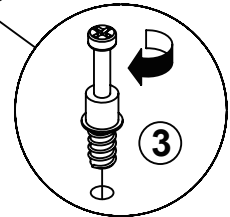
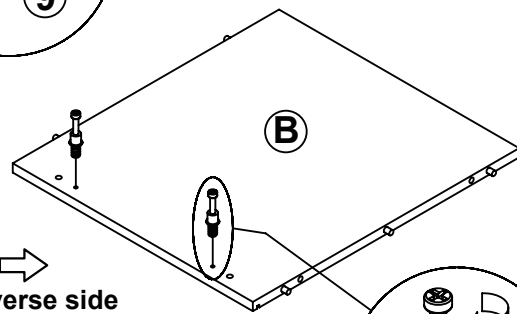

the reverse side

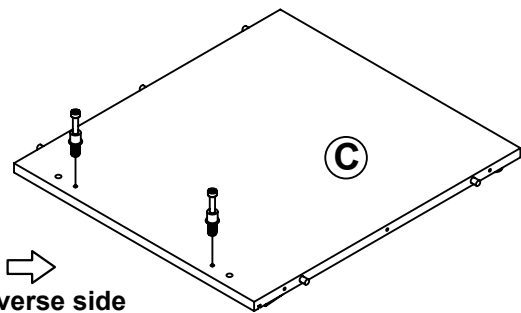

INCORRECT
CORRECT

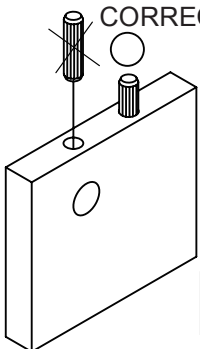

Apply glue on all wooden dowels to ensure integrity of the structure.

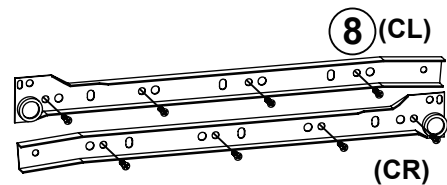
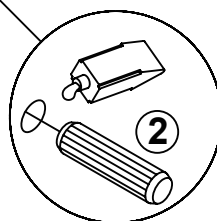

ITEM: 803521

COASTER
FINE FURNITURE

STEP 2

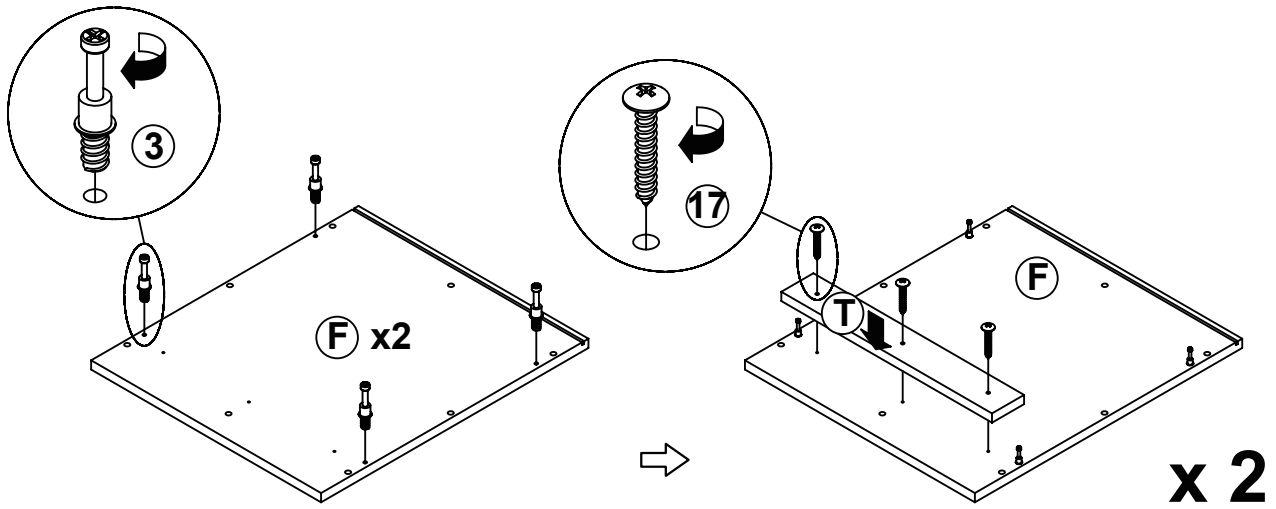

STEP 3

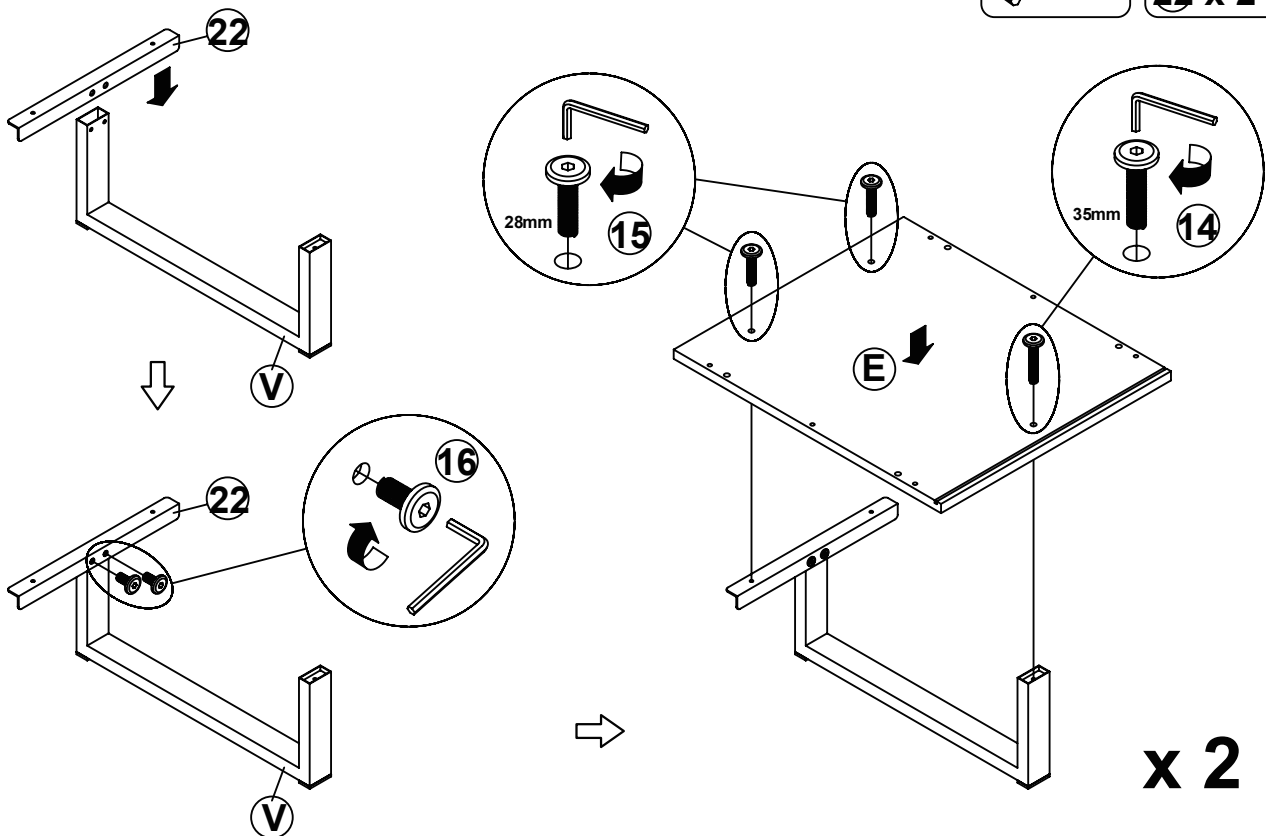
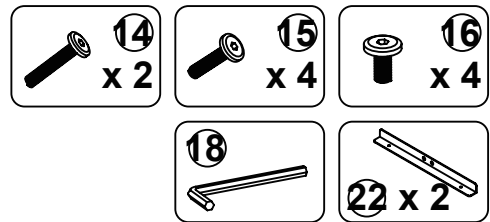

ITEM: 803521

STEP 4

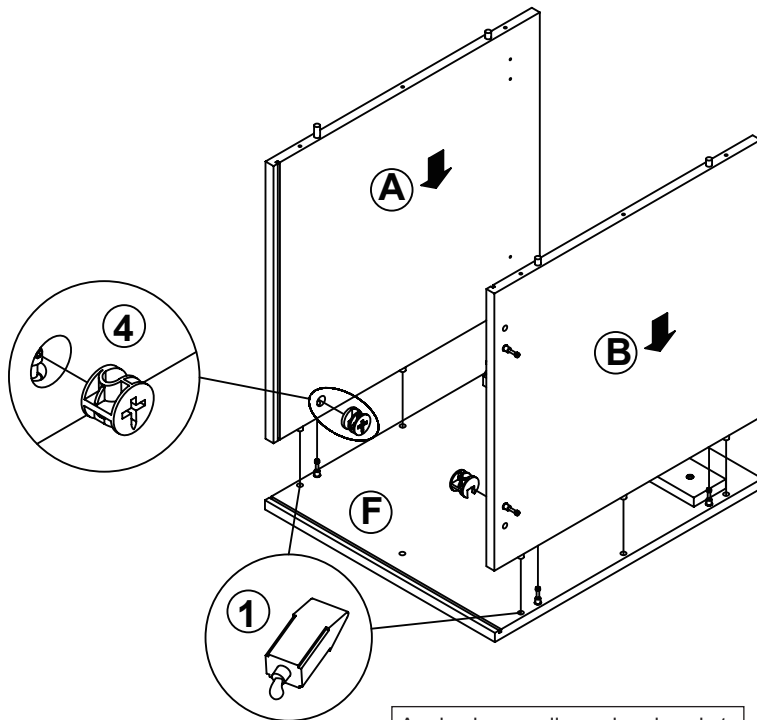
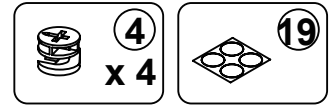

Apply glue on all wooden dowels to ensure integrity of the structure.

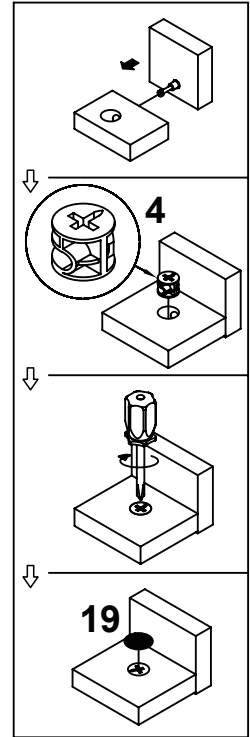

STEP 5

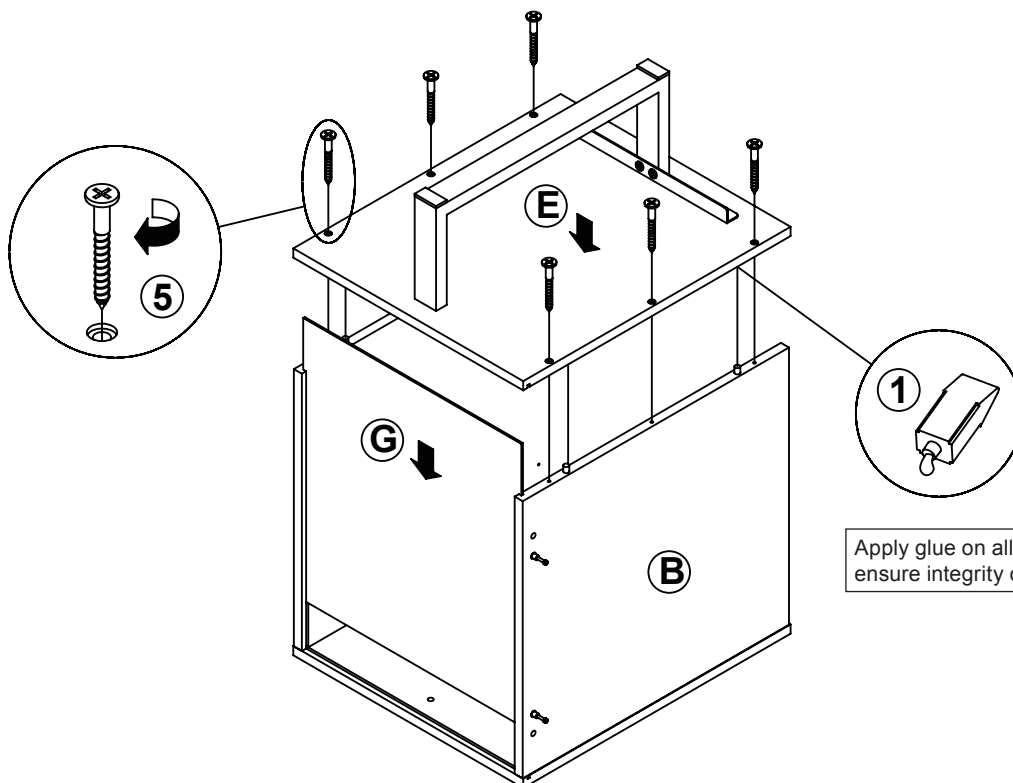
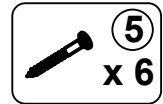

Apply glue on all wooden dowels to ensure integrity of the structure.

ITEM: 803521

STEP 6

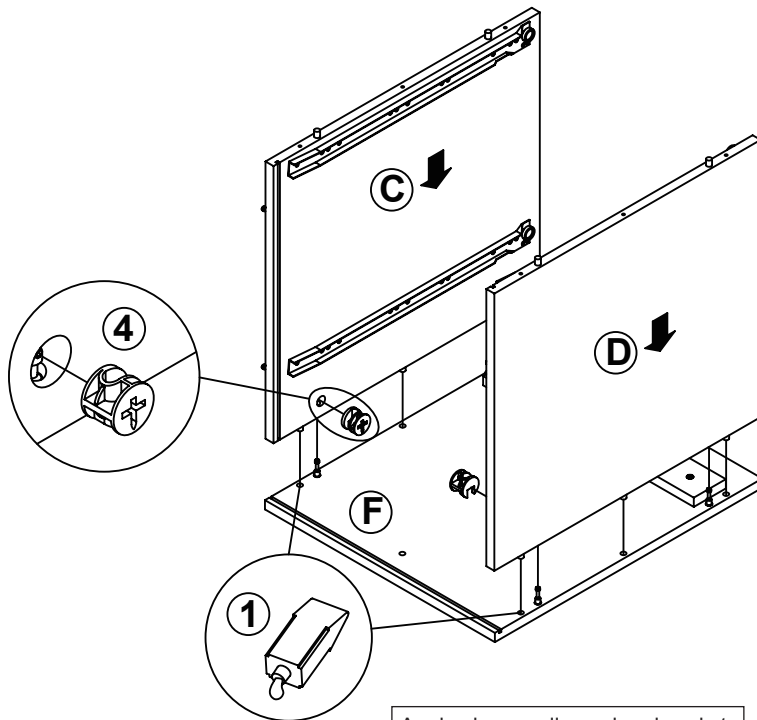
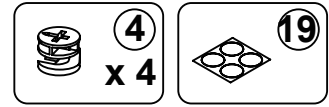

Apply glue on all wooden dowels to ensure integrity of the structure.

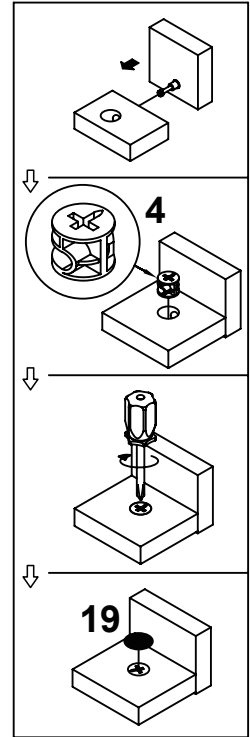

STEP 7

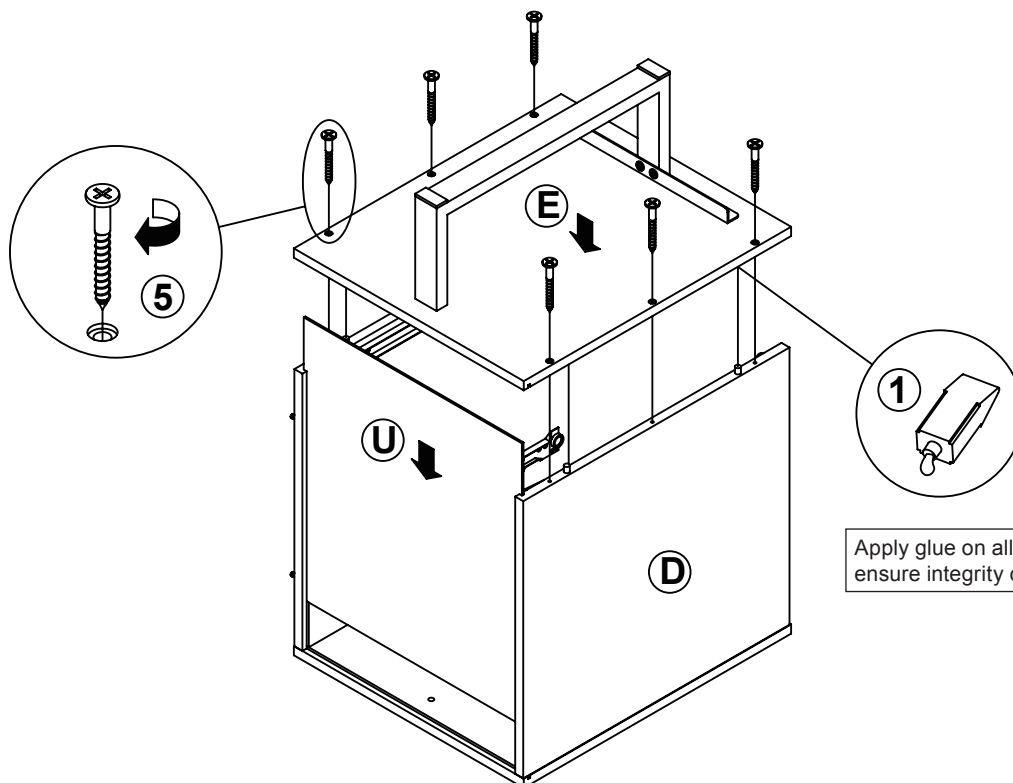
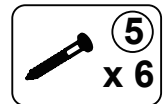

Apply glue on all wooden dowels to ensure integrity of the structure.

ITEM: 803521

STEP 8

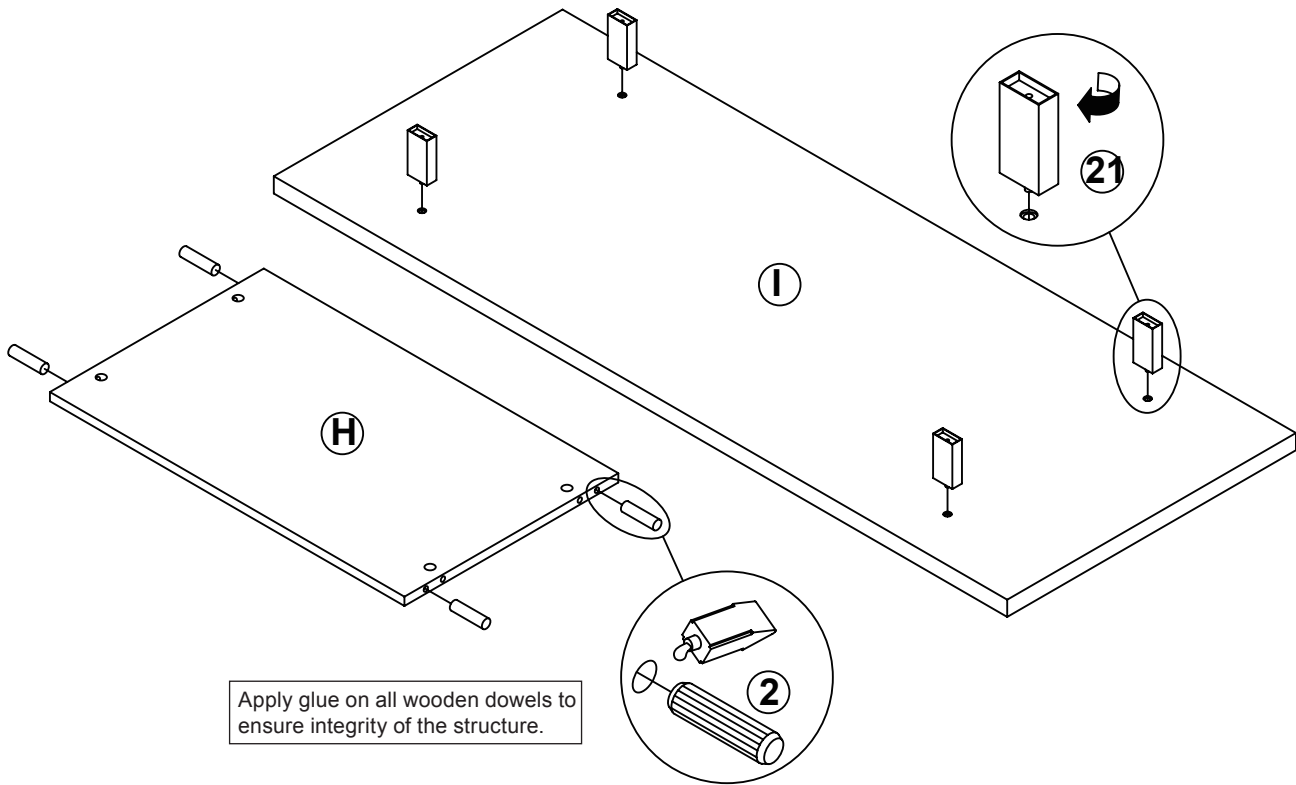
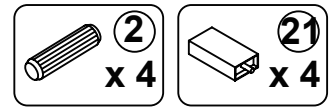

STEP 9

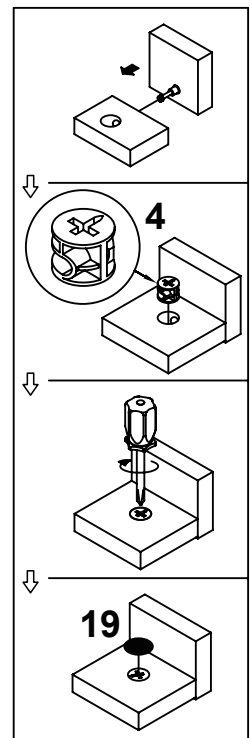
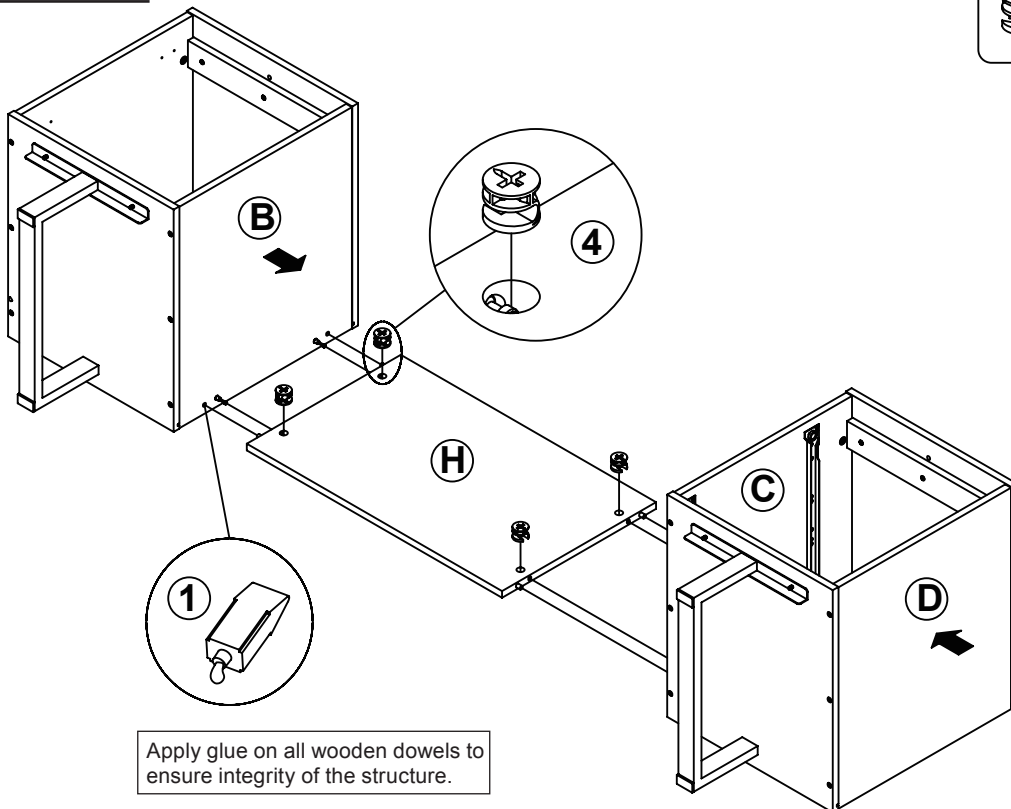
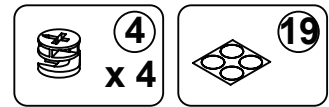

ITEM: 803521

COASTER
FINE FURNITURE

STEP 10

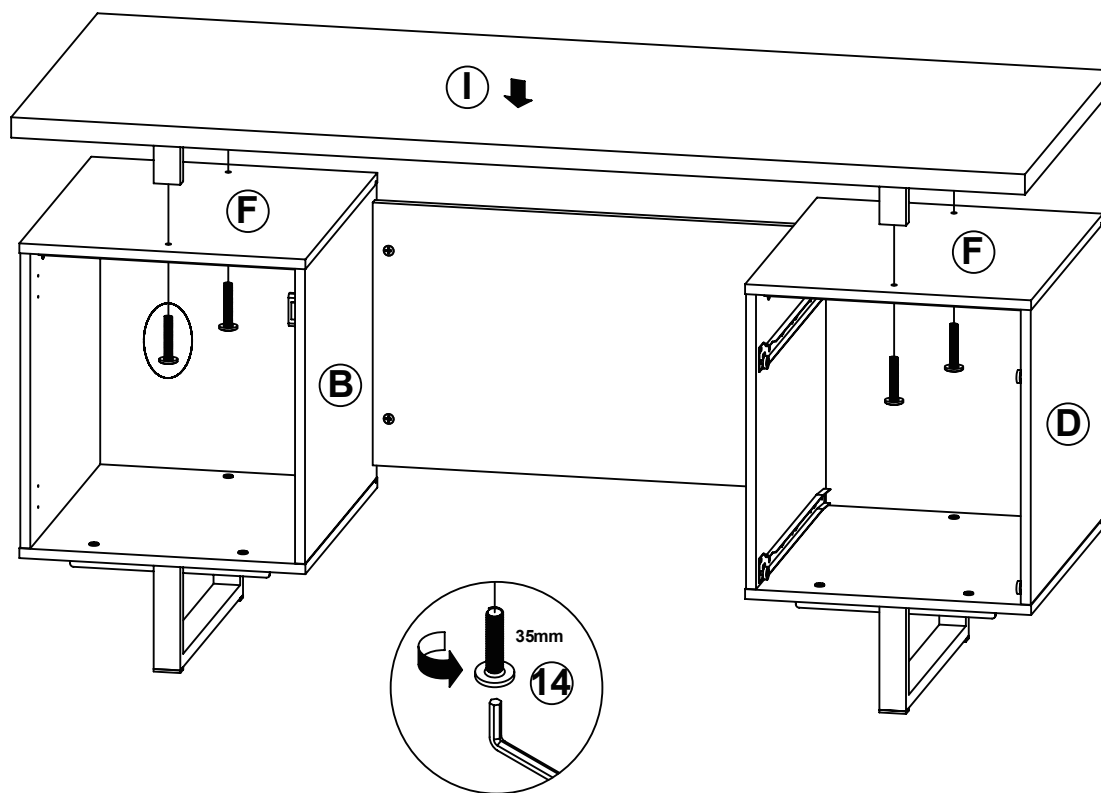

STEP 11

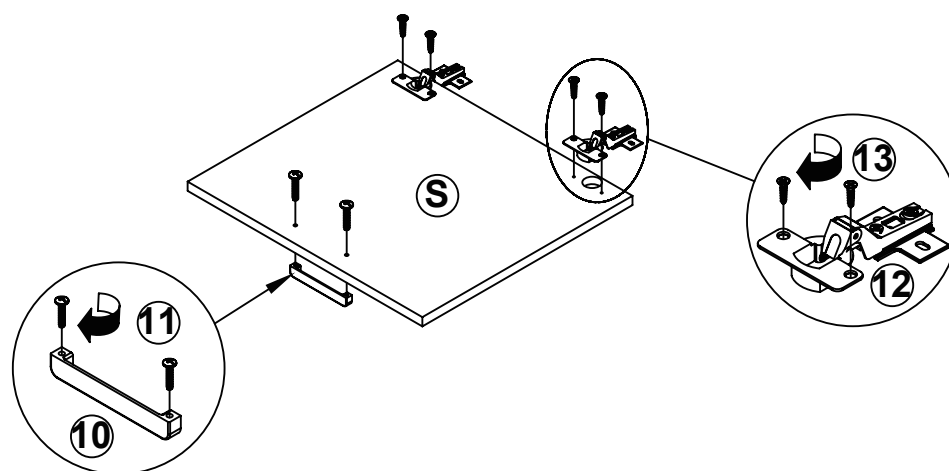
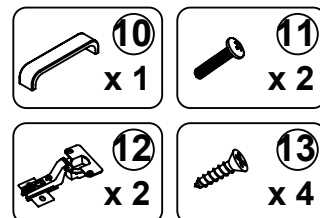

ITEM: 803521

STEP 12-1

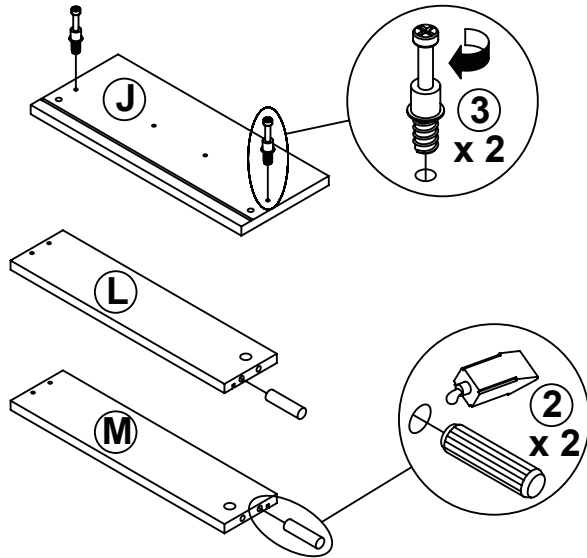

STEP 12-2

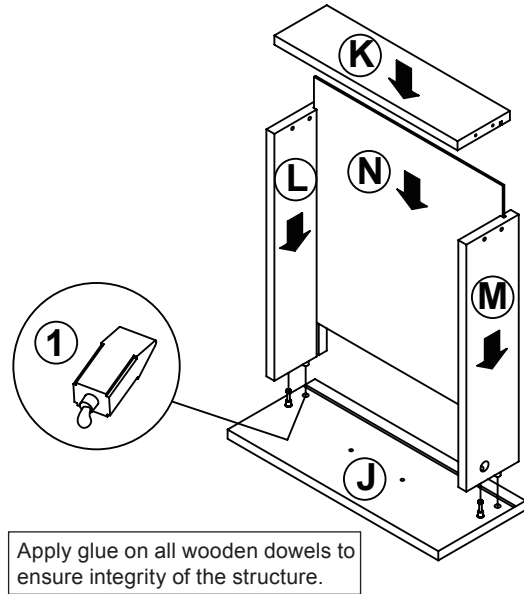

STEP 12-3

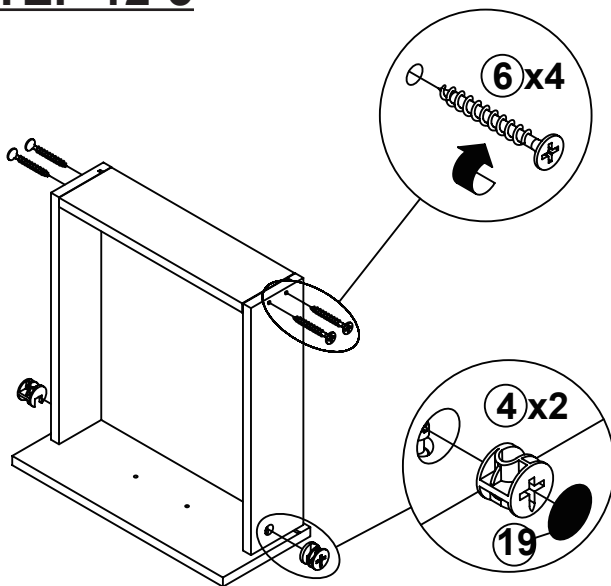

STEP 12-4

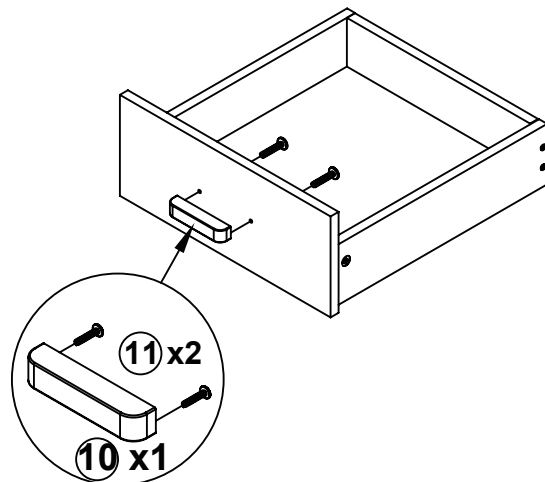

STEP 12-5

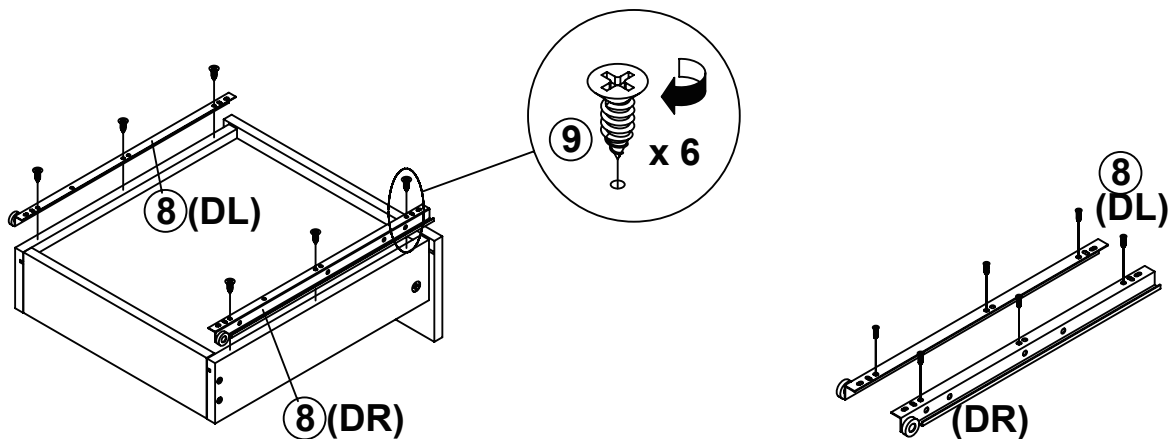

ITEM: 803521

STEP 13-1

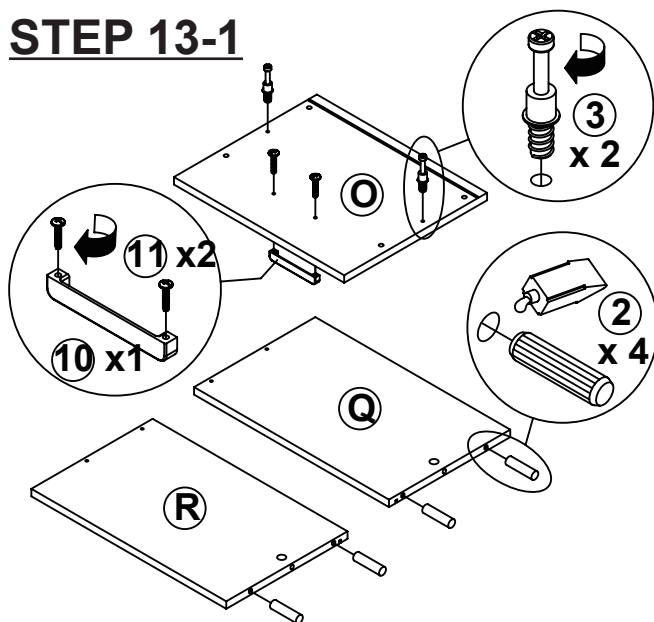

STEP 13-2

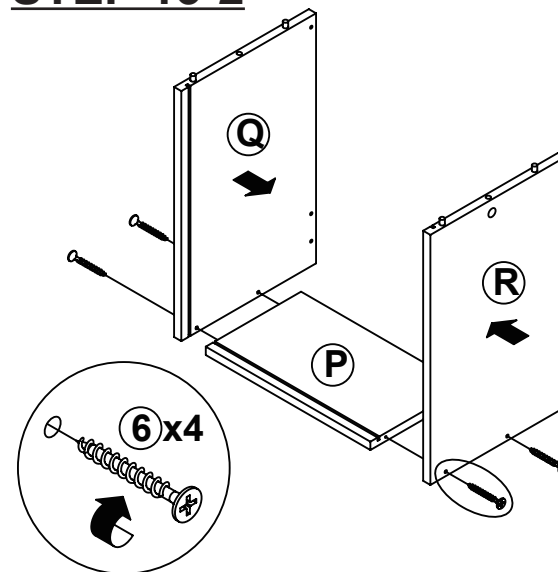

STEP 13-3

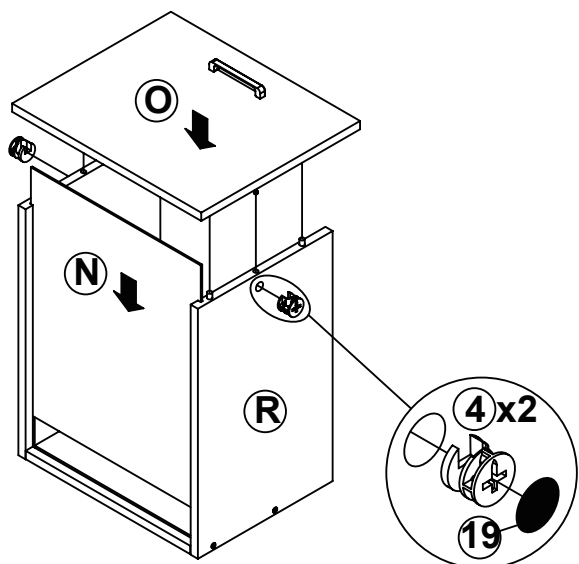

STEP 13-4

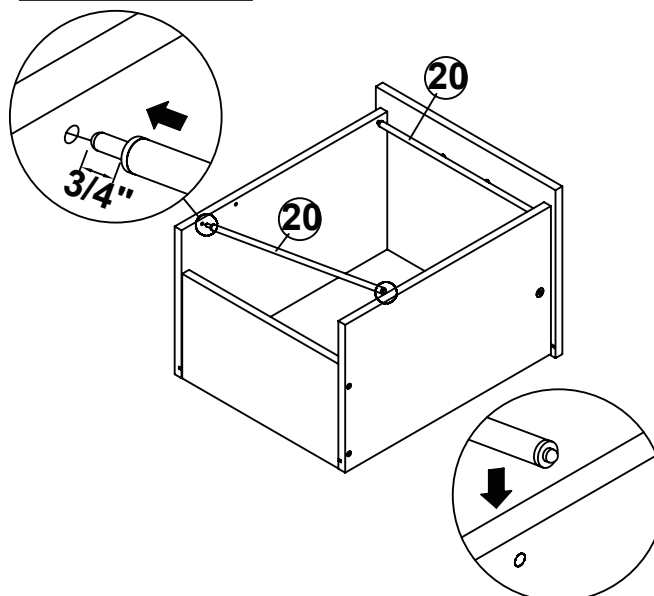

STEP 13-5

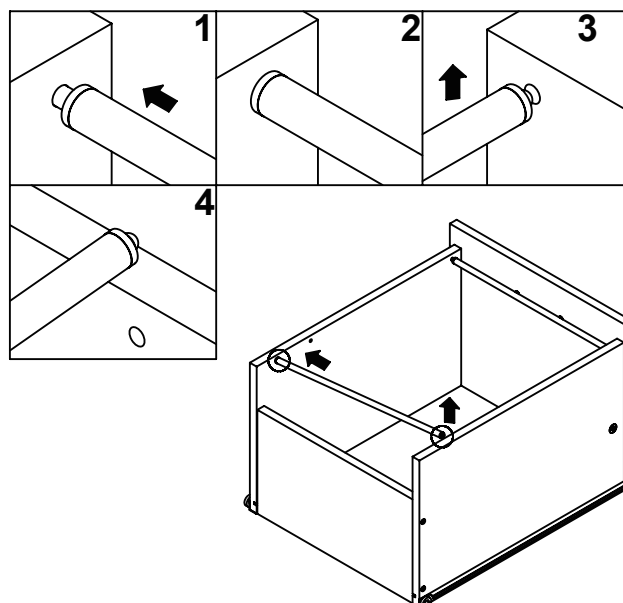
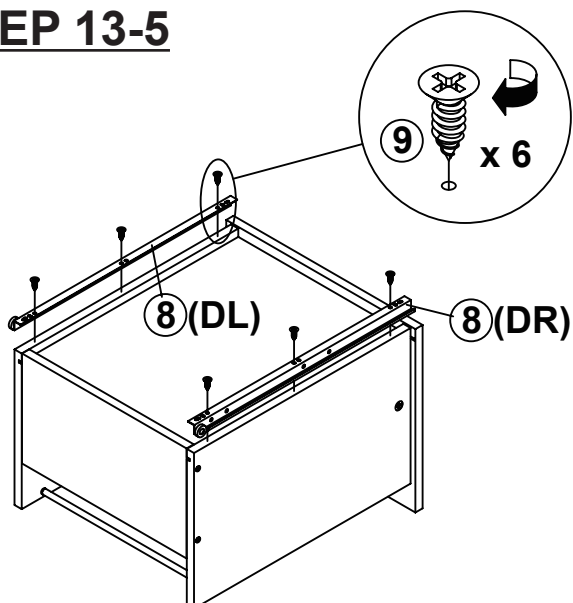

ITEM: 803521

COASTER
FINE FURNITURE

STEP 14

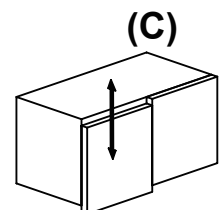
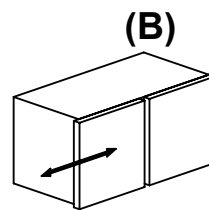
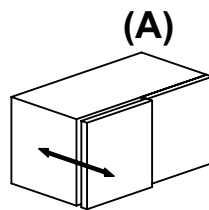
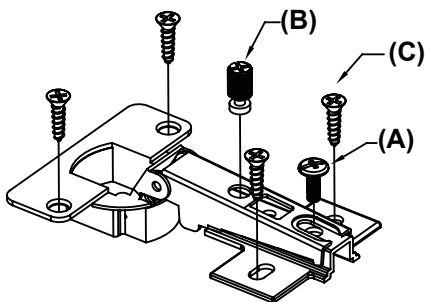
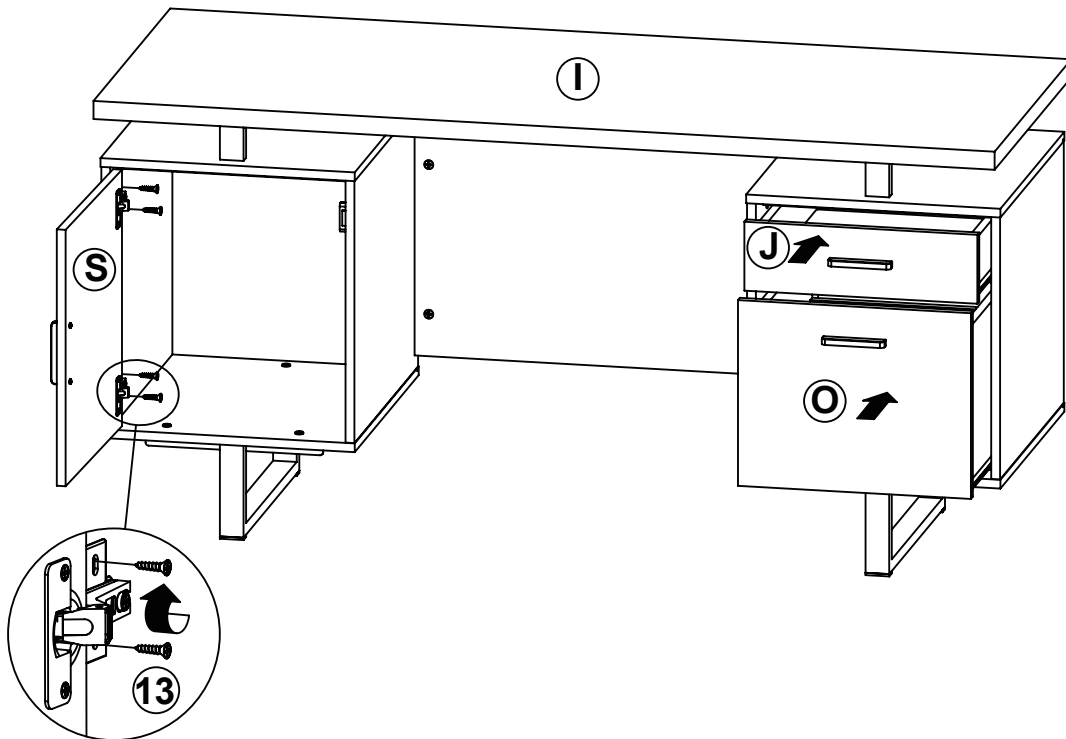
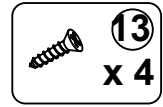

STEP 15

COMPLETE

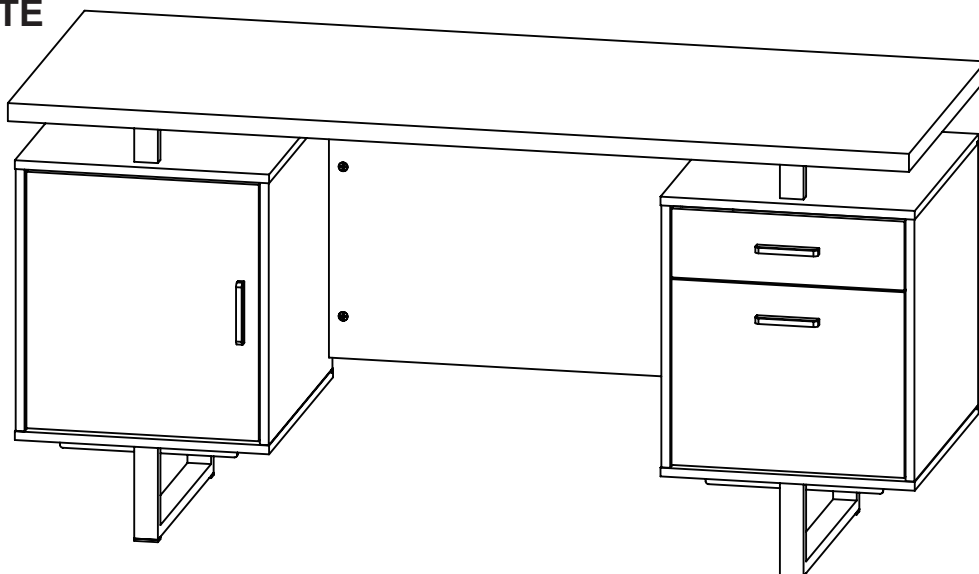

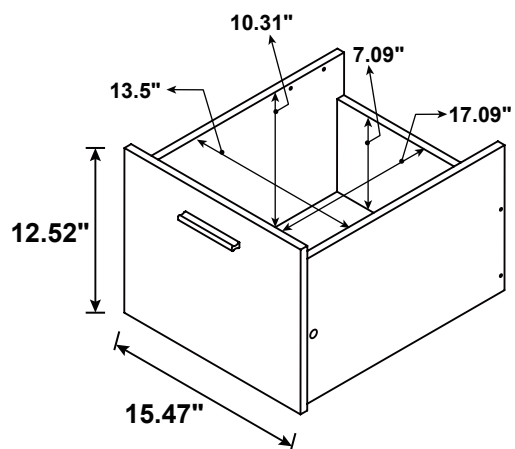
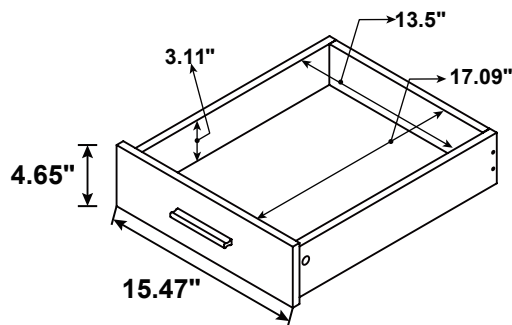
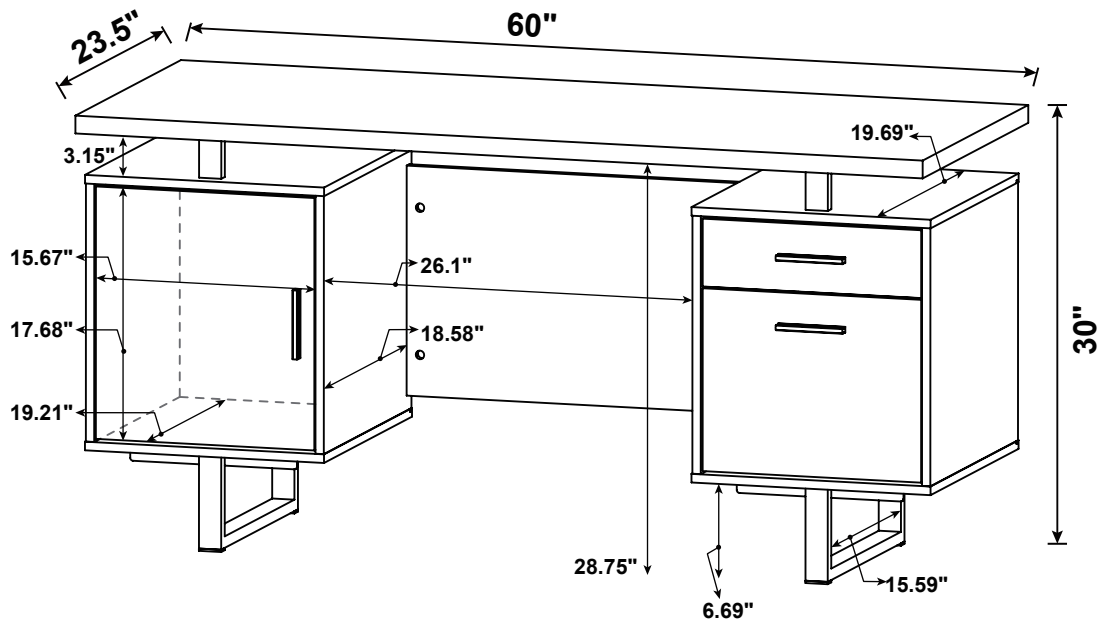

Note : Dimension tolerance $\pm 5\%$