

ASSEMBLY INSTRUCTIONS
COASTER FINE FURNITURE



Fine Furniture for every stage of life

803701
WRITING DESK

ITEM: 803701

ASSEMBLY INSTRUCTIONS

ASSEMBLY TIPS:

1. Remove hardware from box and sort by size.
2. Please check to see that all hardware and parts are present prior to start of assembly.
3. Please follow attached instructions in the same sequence as numbered to assure fast & easy assembly.



WARNING!

1. Don't attempt to repair or modify parts that are broken or defective. Please contact the store immediately.
2. This product is for home use only and not intended for commercial establishments.





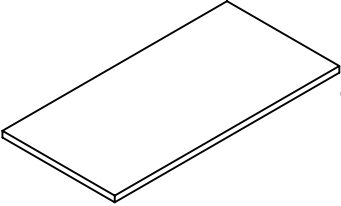
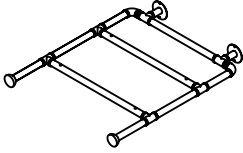
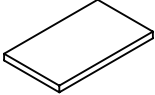
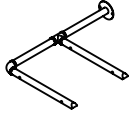
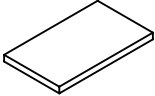
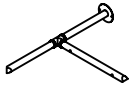
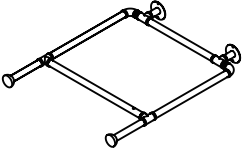
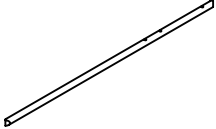

ASSEMBLY TIME

30 MINUTES

PARTS IDENTIFICATION

<p>A TOP</p>  <p>1 PC</p>	<p>E RIGHT METAL FRAME</p>  <p>1 PC</p>
<p>B UPPER CROSS PANEL</p>  <p>1 PC</p>	<p>F "F" METAL FRAME</p>  <p>1 PC</p>
<p>C LOWER CROSS PANEL</p>  <p>1 PC</p>	<p>G "T" METAL FRAME</p>  <p>1 PC</p>
<p>D LEFT METAL FRAME</p>  <p>1 PC</p>	<p>H CROSSBAR</p>  <p>1 PC</p>

HARDWARE IDENTIFICATION

Z					Z				
NO	DESCRIPTION	FIGURE	Q'TY	NO	DESCRIPTION	FIGURE	Q'TY		
1	BOLT M6x44mm BLK		6 PCS	3	LONG SCREW Ø 4.5x42mm BLK		8 PCS		
2	SHORT SCREW Ø 5x23mm BLK		12 PCS	4	ALLEN WRENCH 4mm SR		1 PC		

NOTE:

Phillips head screw driver is required in the assembly process; however, manufacturer does not provide this item.

ITEM: 803701

COASTER
FINE FURNITURE

STEP 1

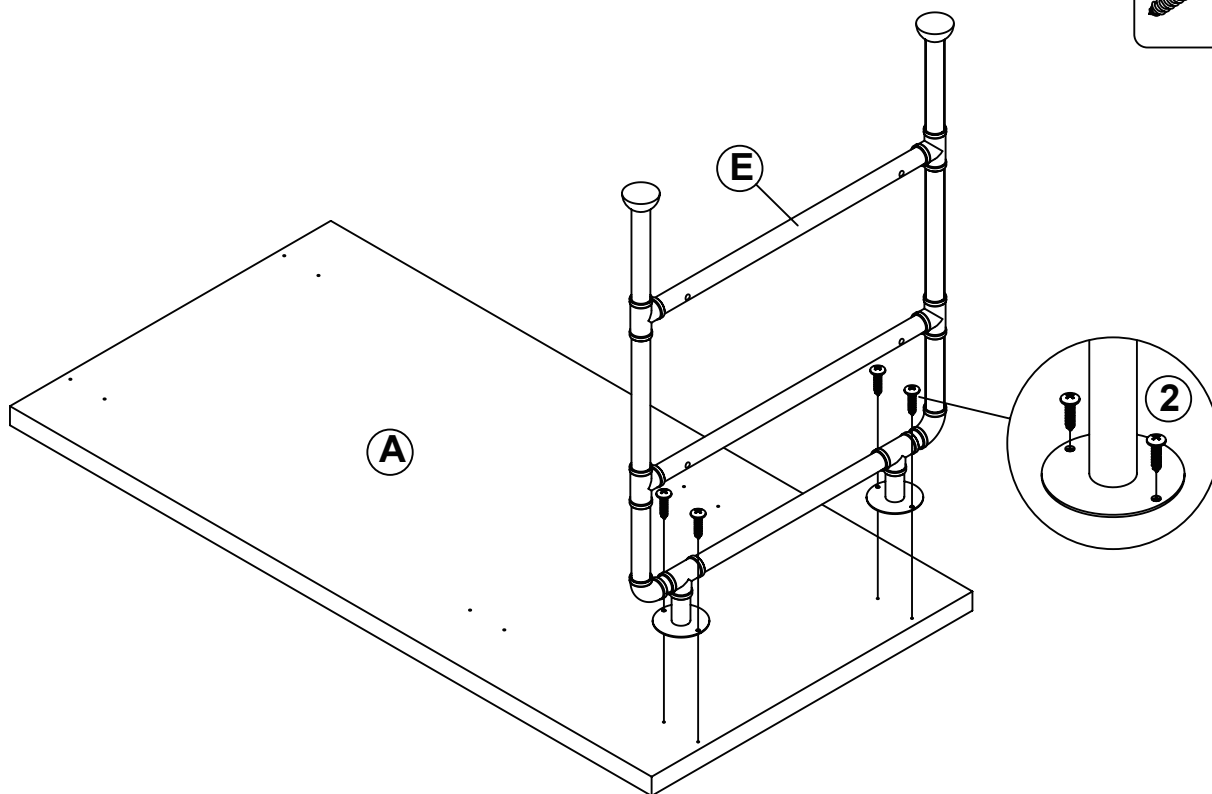
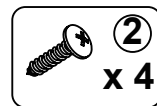

STEP 2

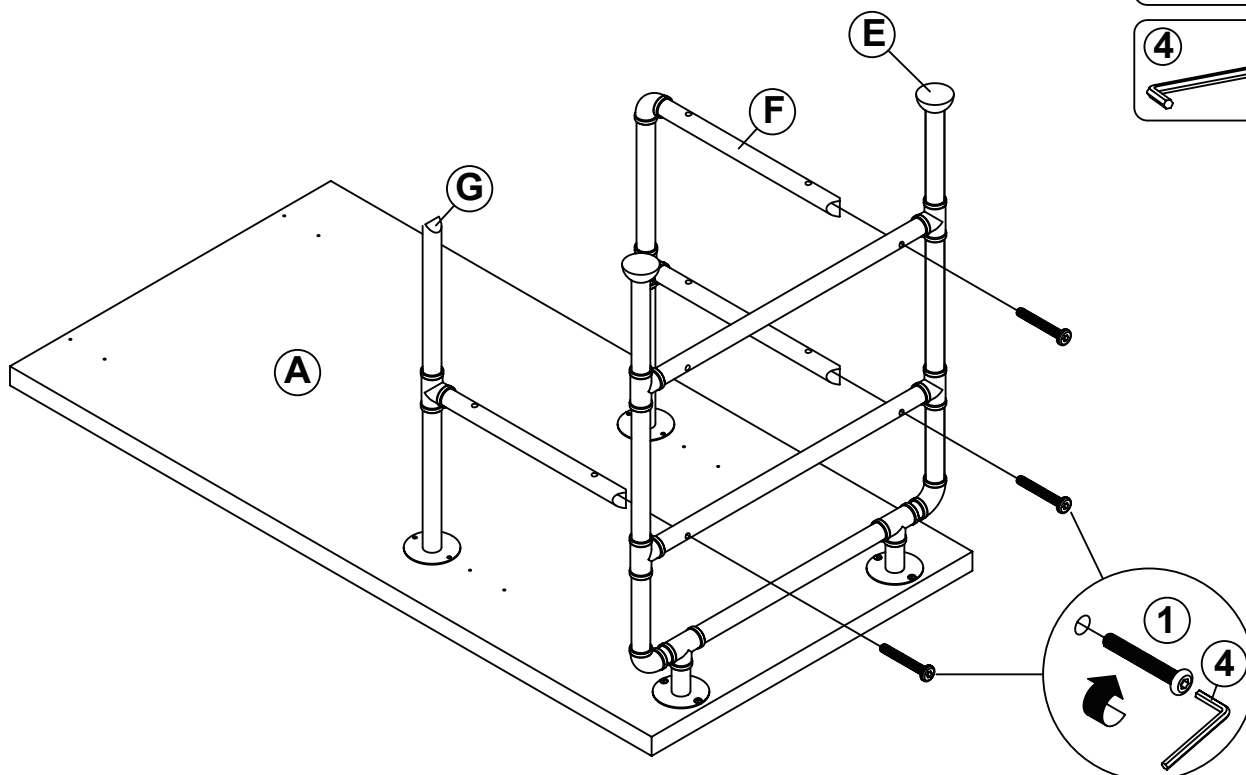
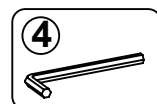
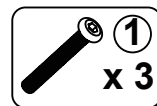

ITEM: 803701

COASTER
FINE FURNITURE

STEP 3

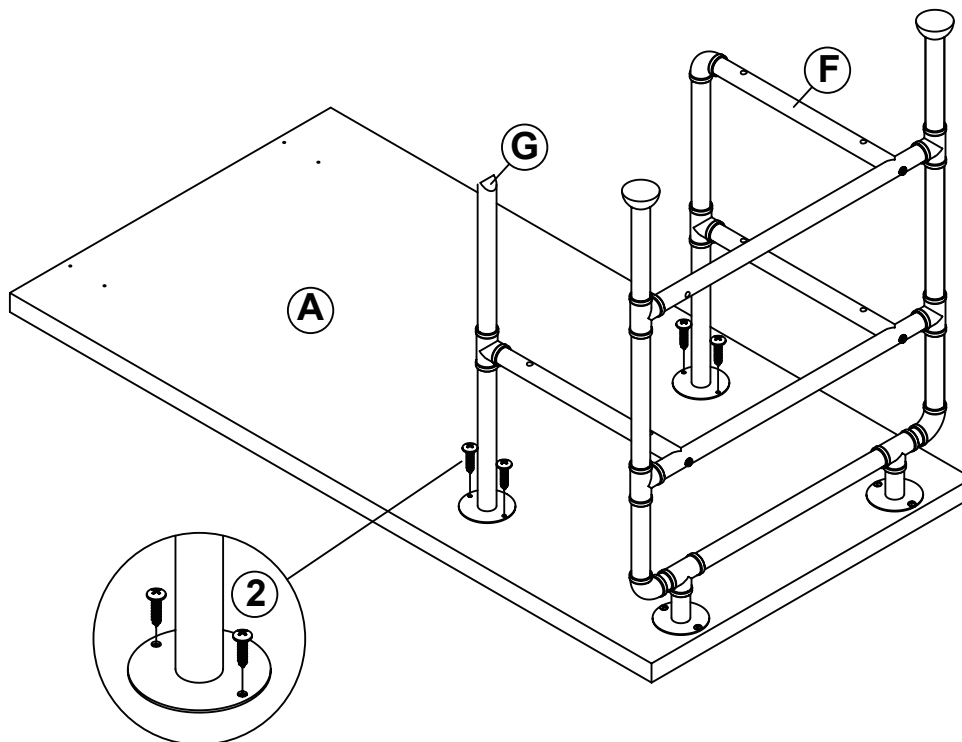
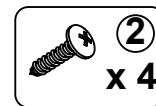

STEP 4

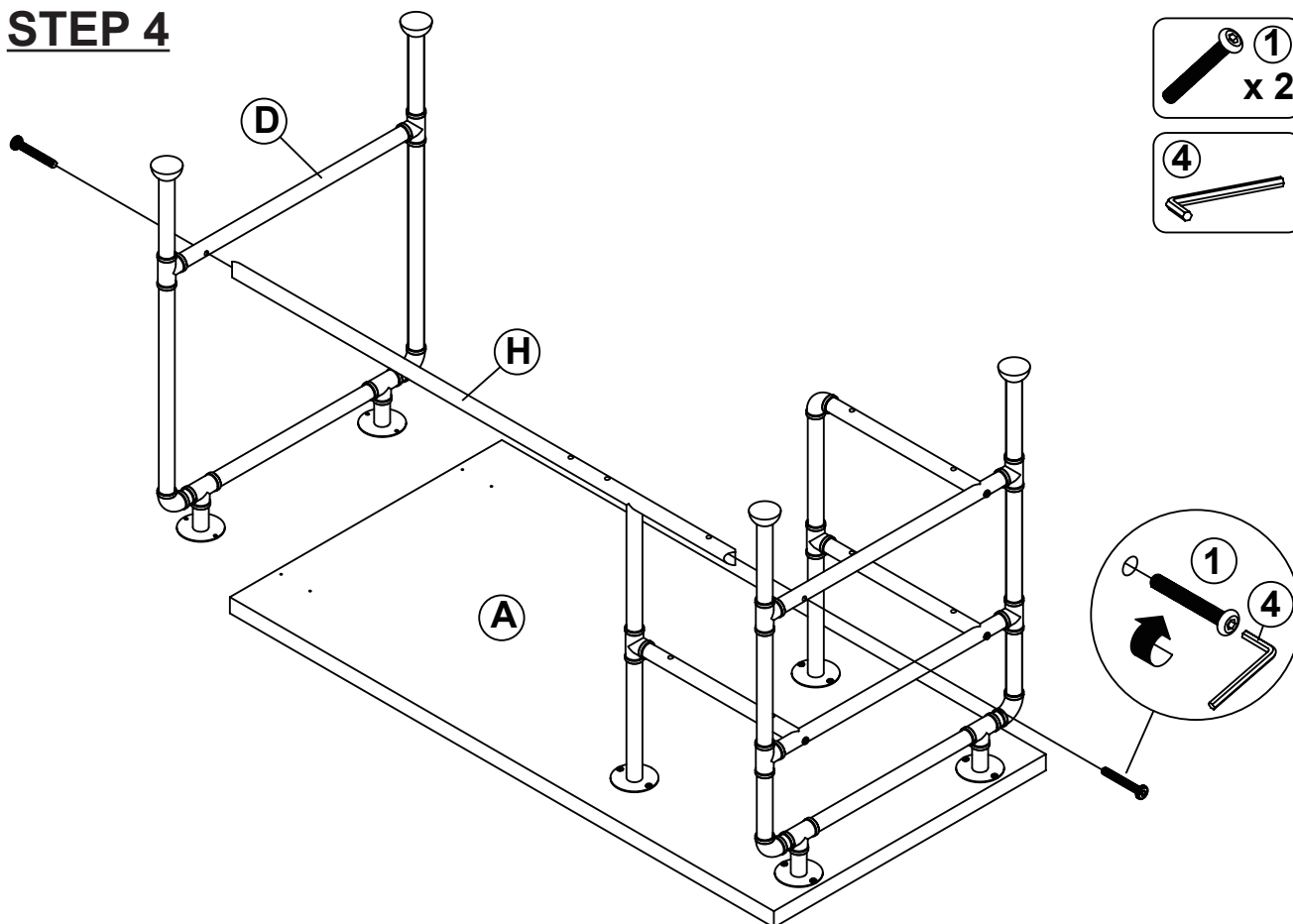
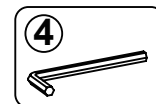
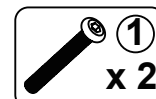

ITEM: 803701

COASTER
FINE FURNITURE

STEP 5

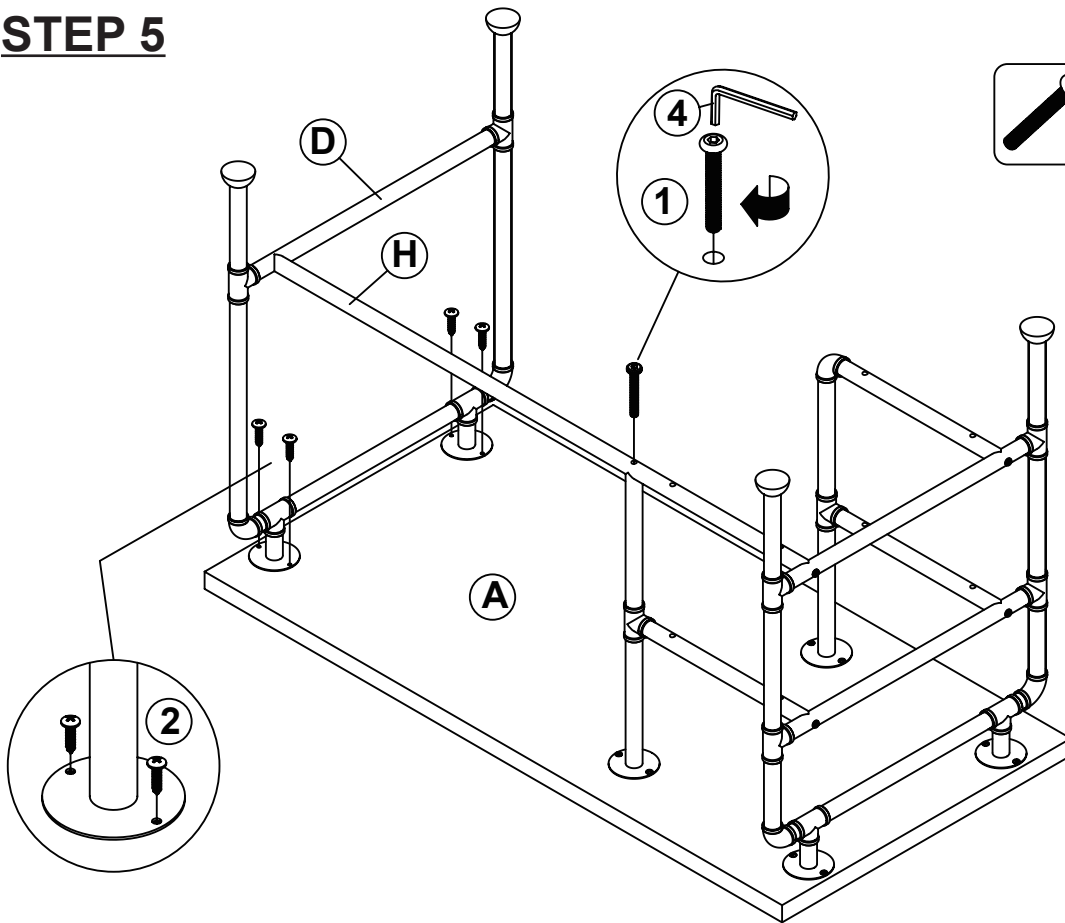

STEP 6

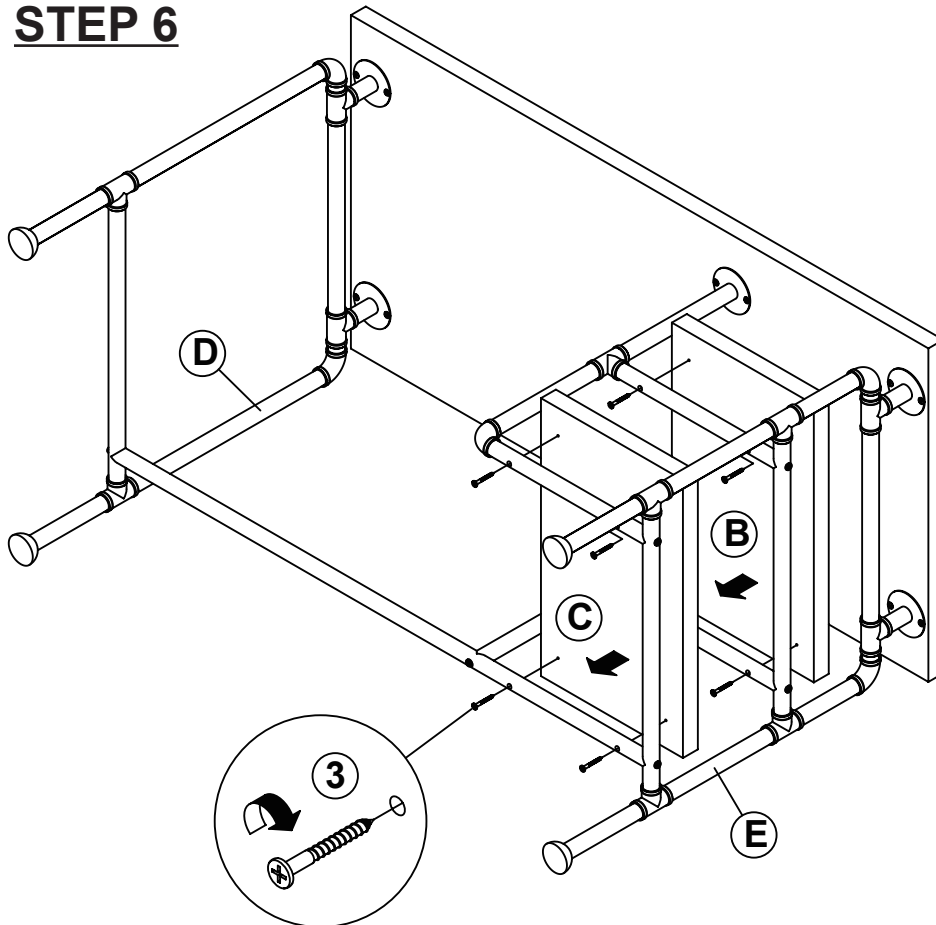

COMPLETE

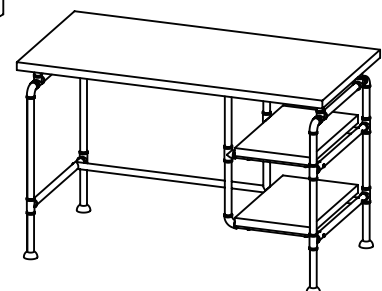

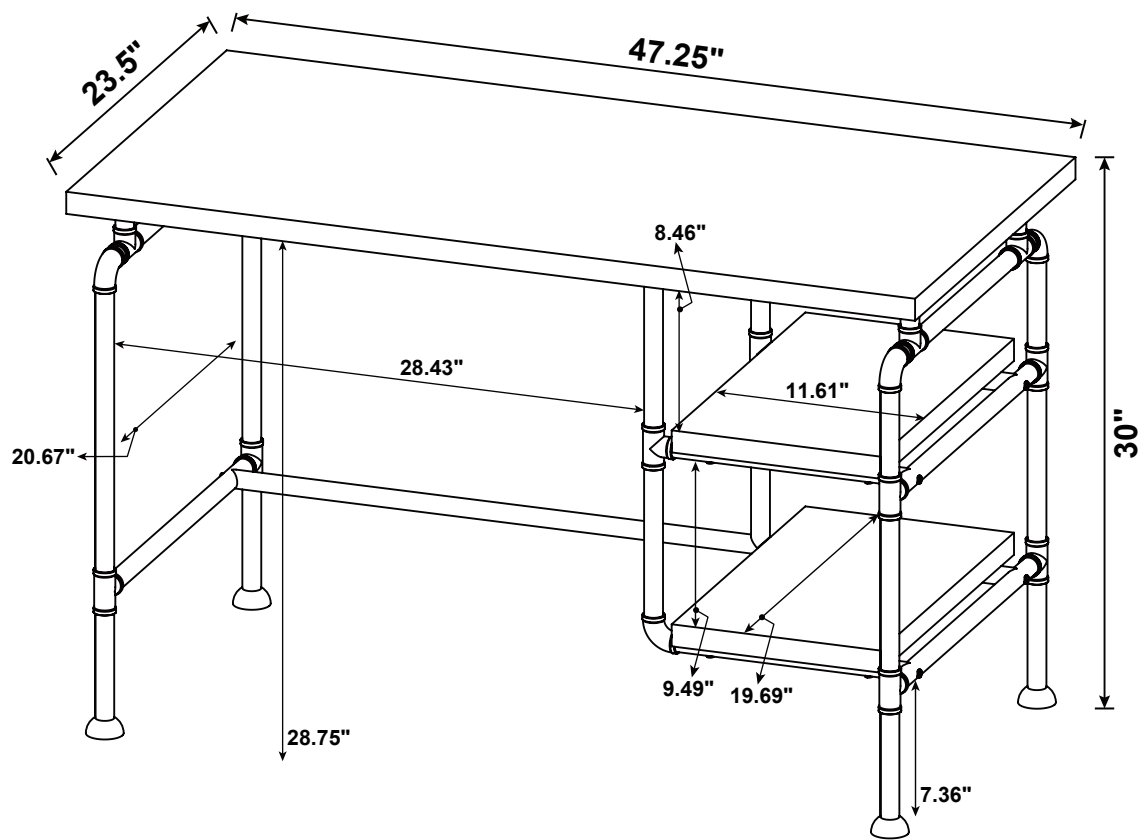

Note : Dimension tolerance $\pm 5\%$