

ASSEMBLY INSTRUCTIONS
COASTER FINE FURNITURE



Fine Furniture for every stage of life

182632
BAR UNIT

ITEM:182632



ASSEMBLY INSTRUCTIONS

ASSEMBLY TIPS:

1. Remove hardware from box and sort by size.
2. Please check to see that all hardware and parts are present prior to start of assembly.
3. Please follow attached instructions in the same sequence as numbered to assure fast & easy assembly.



WARNING!

1. Don't attempt to repair or modify parts that are broken or defective. Please contact the store immediately.
2. This product is for home use only and not intended for commercial establishments.

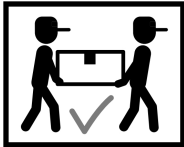

ASSEMBLY TIME 99 MINUTES

PARTS IDENTIFICATION

A DESKTOP BOARD

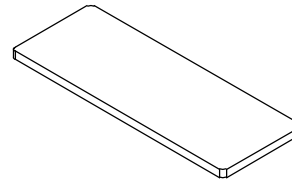

1PC

B TOP PANEL

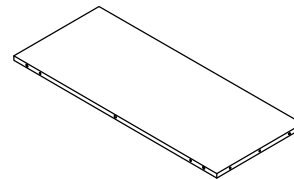

1PC

C LEFT PANEL

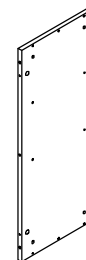

1PC

D RIGHT PANEL

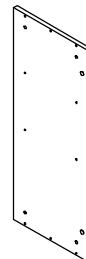

1PC

E MIDDLE SUPPORT PANEL





1PC

ITEM:182632

ASSEMBLY INSTRUCTIONS

PARTS IDENTIFICATION

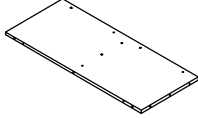
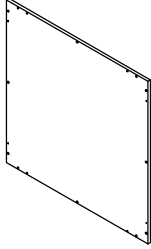

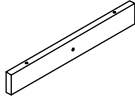
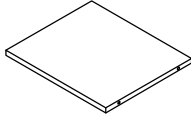
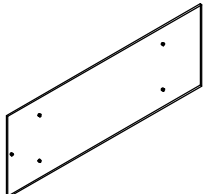
F	BOTTOM PANEL		1PC
G	FRONT PANEL		1PC
H	LEFT OUTSIDE PANEL		1PC
I	RIGHT OUTSIDE PANEL		1PC
J	SUPPORT PANEL		2PCS
K	SHELF PANEL		4PCS
L	SIDE GLASS		2PCS

ITEM:182632

ASSEMBLY INSTRUCTIONS

PARTS IDENTIFICATION



M

FOOTREST BAR

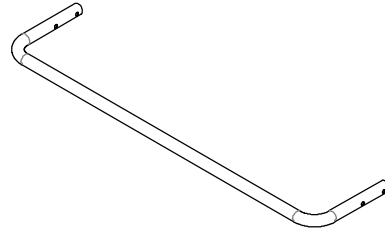

1PC

N

GLASS HOLDER

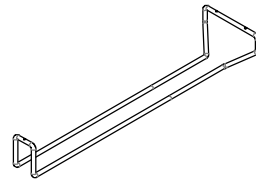

2PCS

O

FOOTREST LEG



2PCS

P

□ CROSSBAR

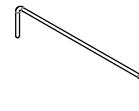

2PCS

Q

PLASTIC BAR

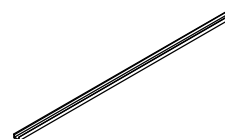

2PCS



















ITEM:182632



ASSEMBLY INSTRUCTIONS

HARDWARE IDENTIFICATION

Z

1	CAM-BOLT (38mm SR)		14PCS	11	CAP (ϕ 25mm)		2PCS
2	CAM-LOCK (ϕ 15mm SR)		14PCS	12	LEVELER (1/4" x 18mm)		2PCS
3	WOOD DOWEL (8 x 30mm)		12PCS	13	ROUND CAP (ϕ 30mm)		2PCS
4	LONG WOOD DOWEL (8 x 50mm)		4PCS	14	NUT		2PCS
5	LONG SCREW (8 x 38mm)		23PCS	15	SCREW (3.5 x 15mm)		6PCS
6	SHORT BOLT (1/4" x 12mm)		4PCS	16	GLUE		1PC
7	MEDIUM BOLT (1/4" x 22mm)		2PCS	17	BOLT (1/4" x 35mm)		4PCS
8	LONG BOLT (1/4" x 32mm)		8PCS	18	COVER		4PCS
9	WASHER (ϕ 16mm)		2PCS	19	ALLEN WRENCH (4mm)		1PC
10	PLASTIC WASHER (ϕ 15mm)		2PCS				

ITEM:182632



ASSEMBLY INSTRUCTIONS

STEP 1 Do not tighten until each step is completed or instructed.

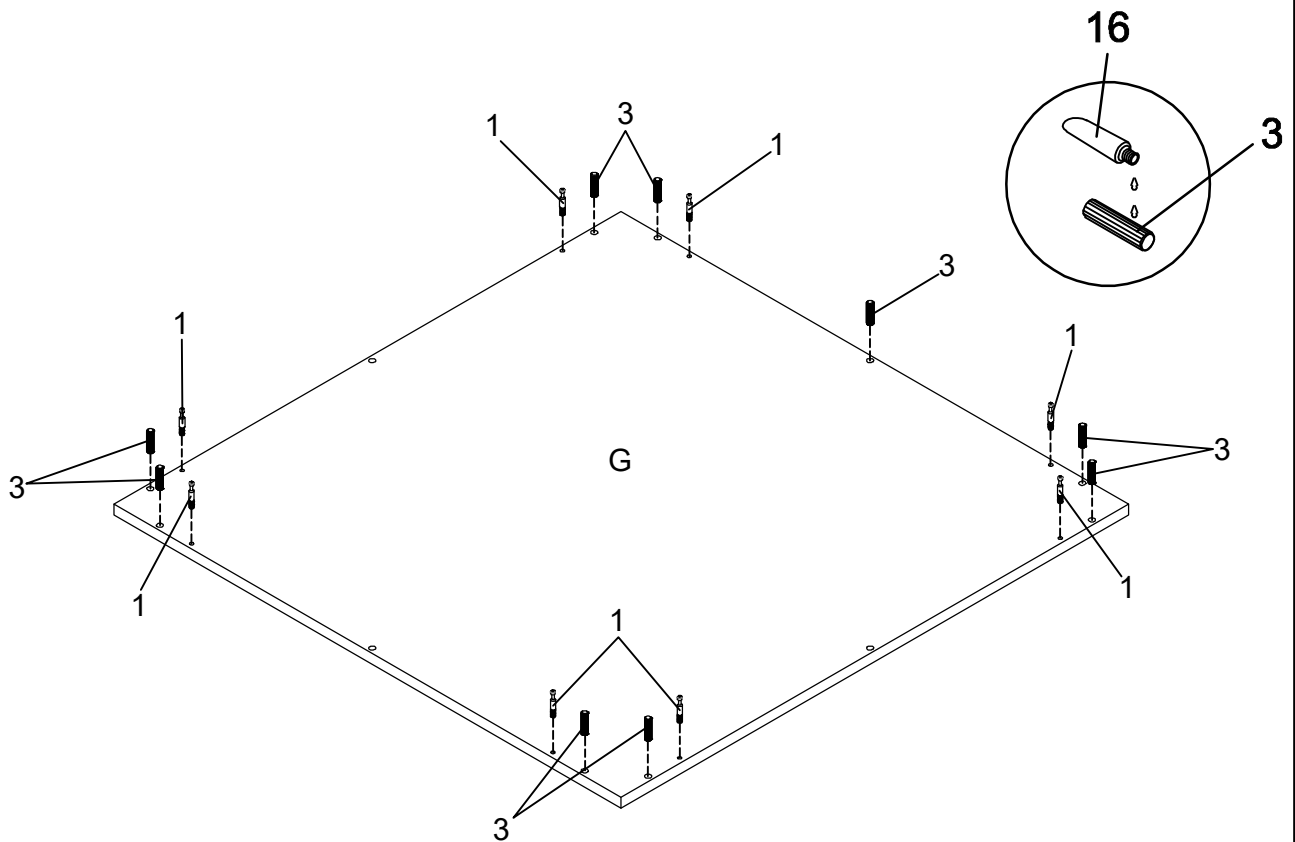

STEP 2

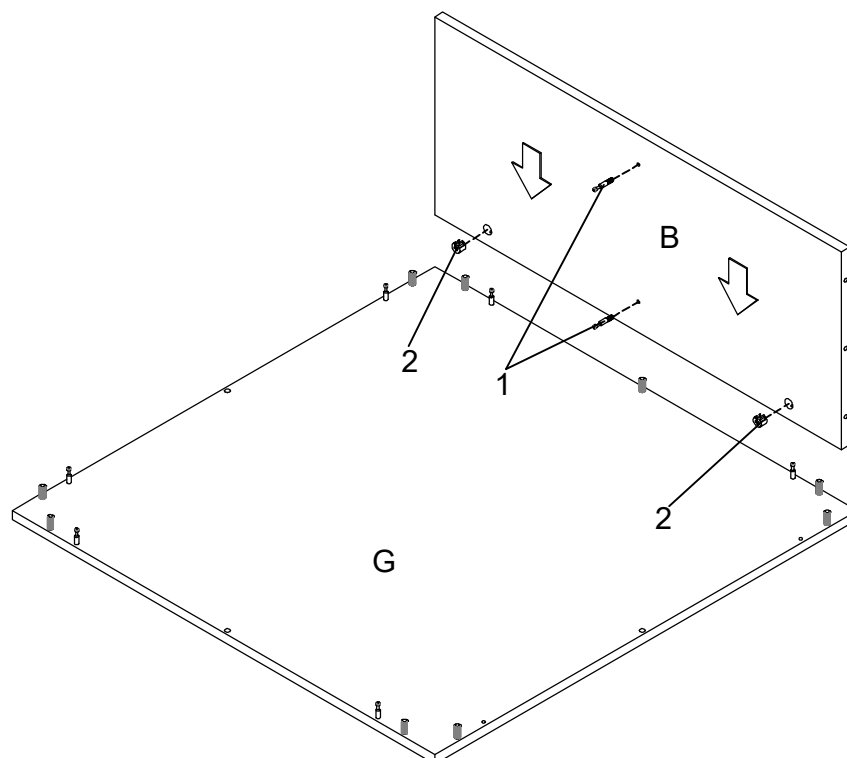

ITEM:182632

ASSEMBLY INSTRUCTIONS

STEP 3

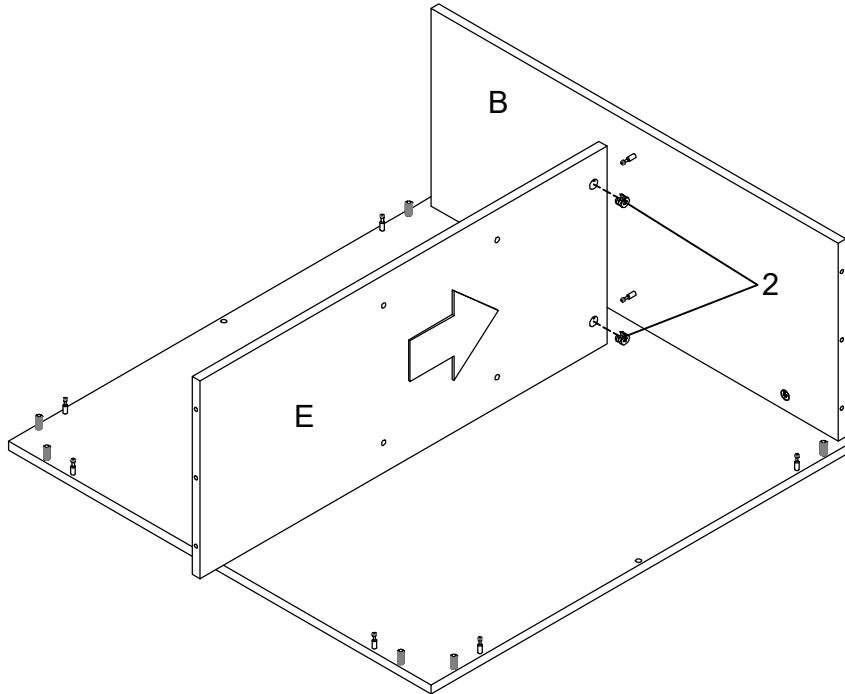

STEP 4

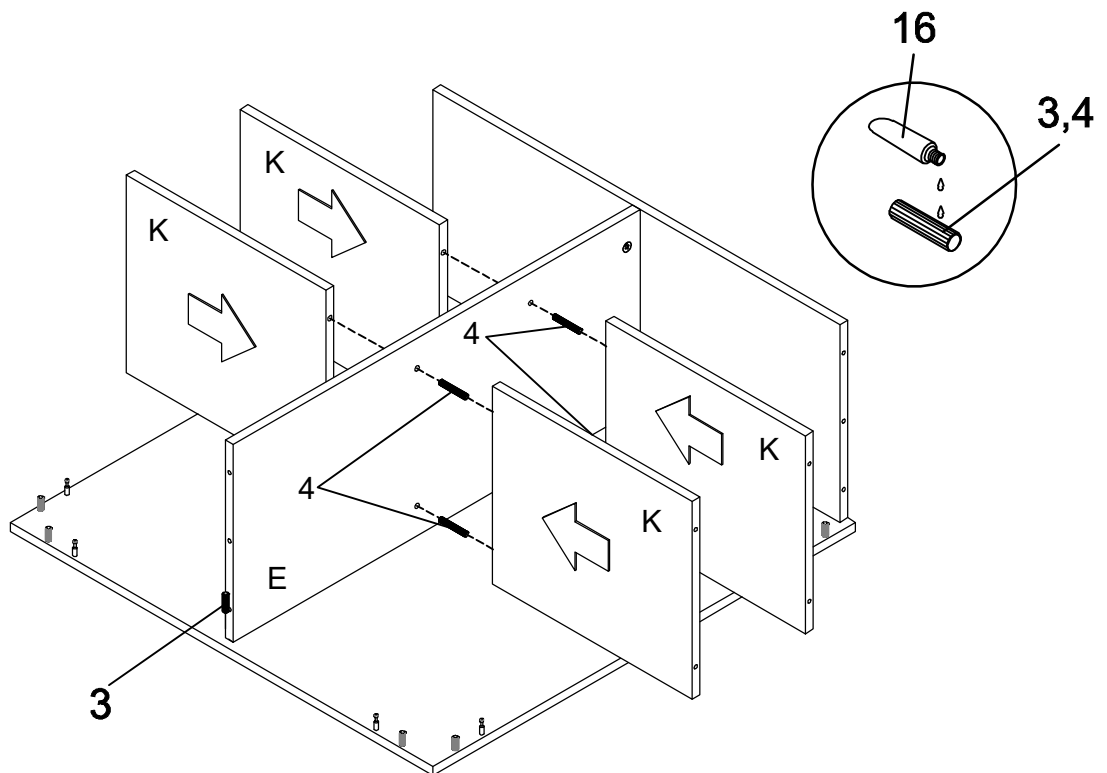

ITEM:182632

ASSEMBLY INSTRUCTIONS

STEP 5

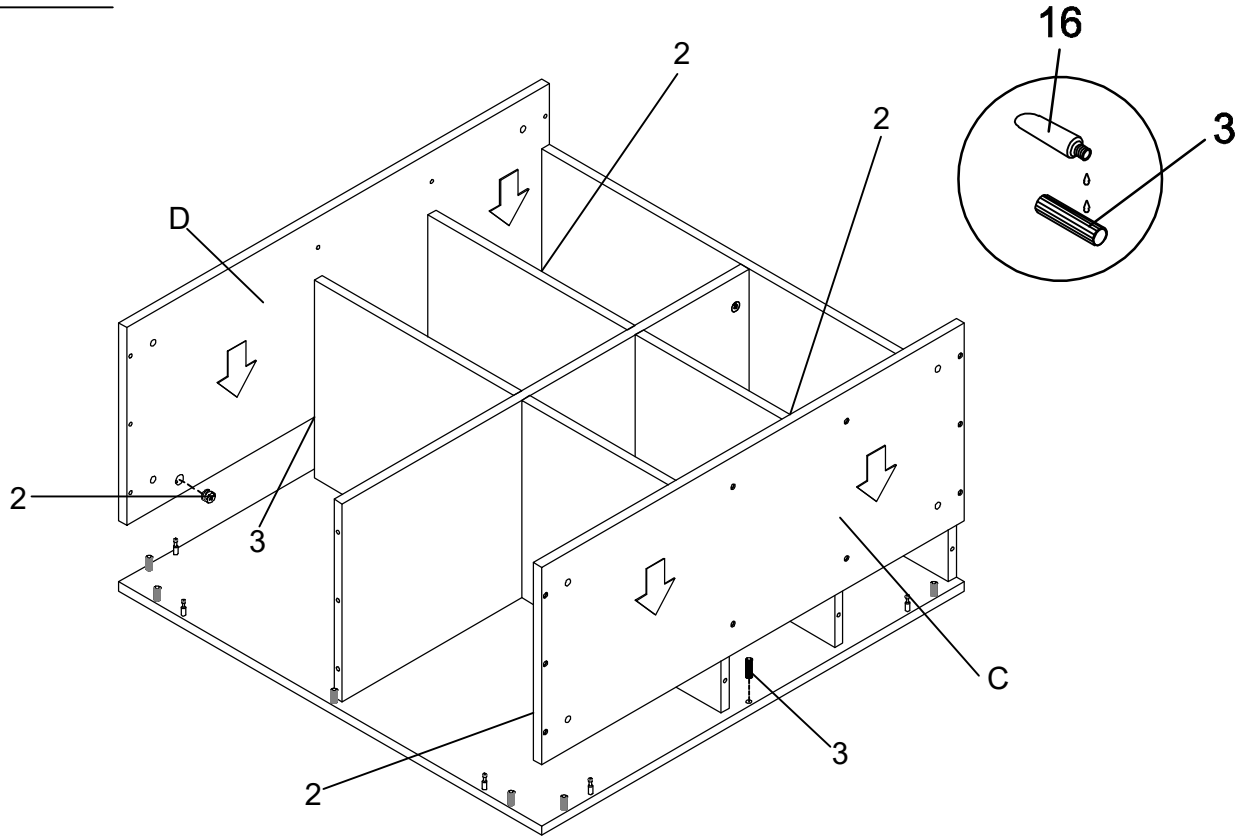

STEP 6

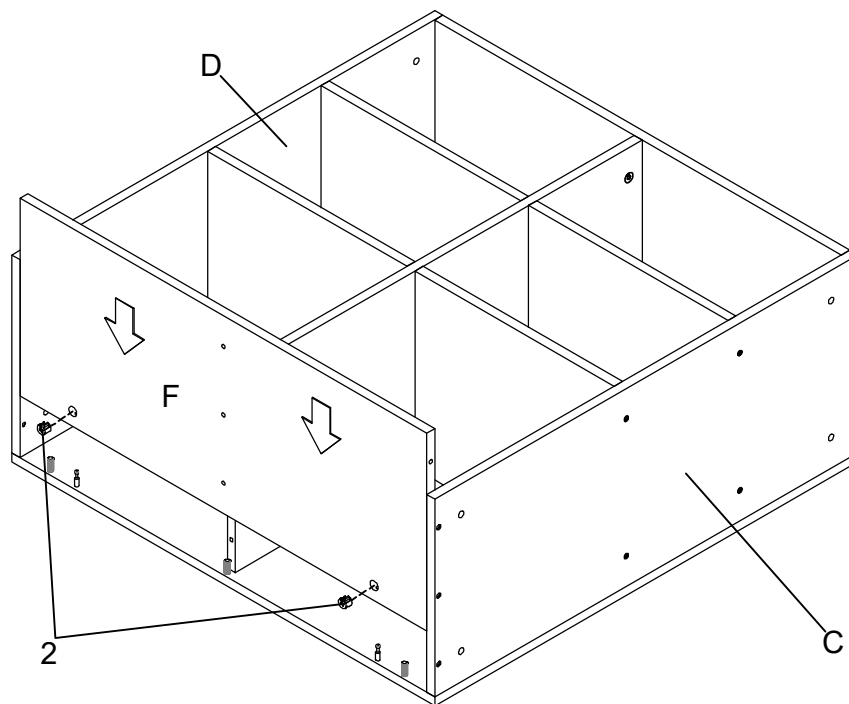

ITEM:182632

ASSEMBLY INSTRUCTIONS

STEP 7

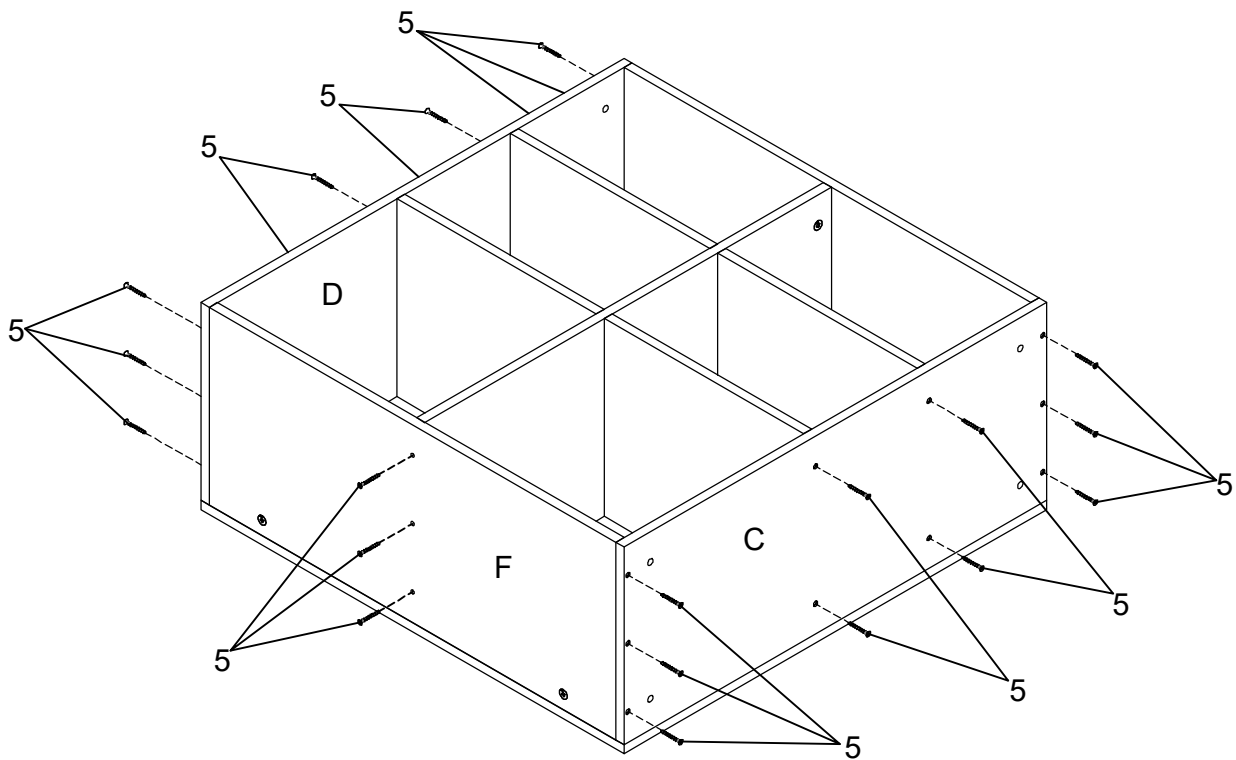

STEP 8

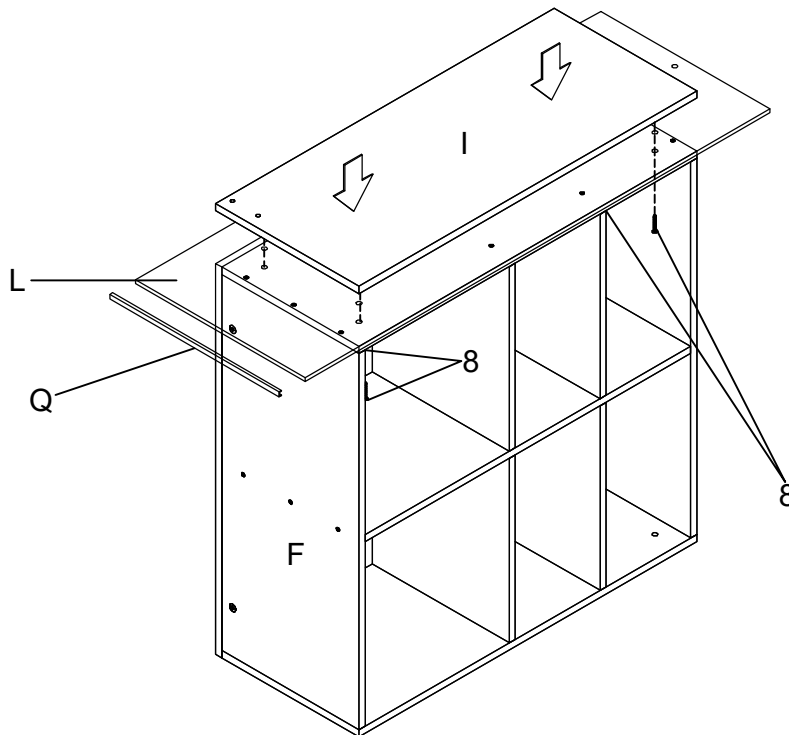

ITEM:182632

ASSEMBLY INSTRUCTIONS

STEP 9

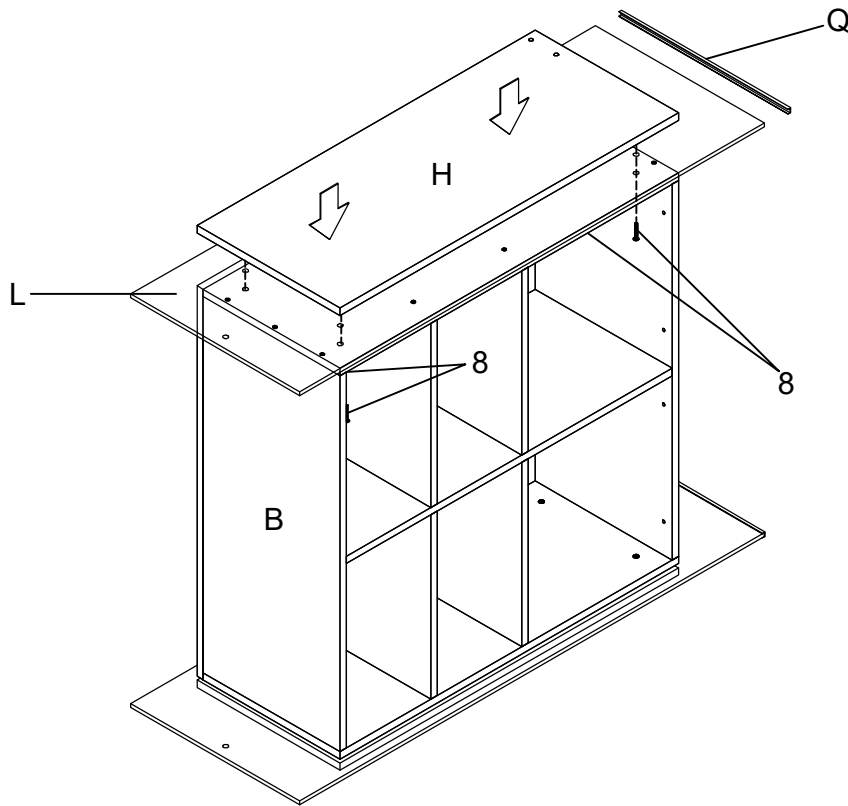

STEP 10

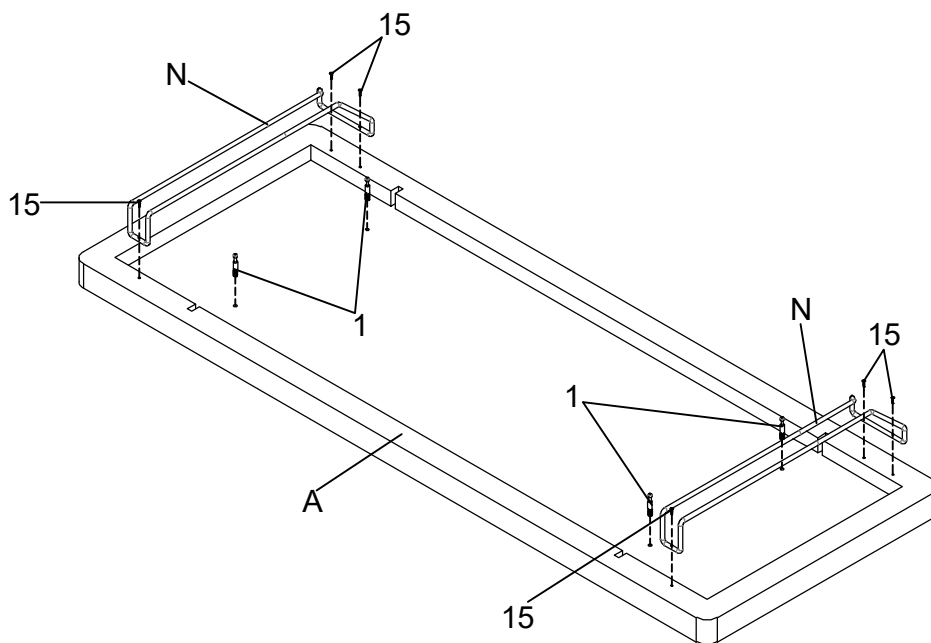

ITEM:182632

ASSEMBLY INSTRUCTIONS

STEP 11

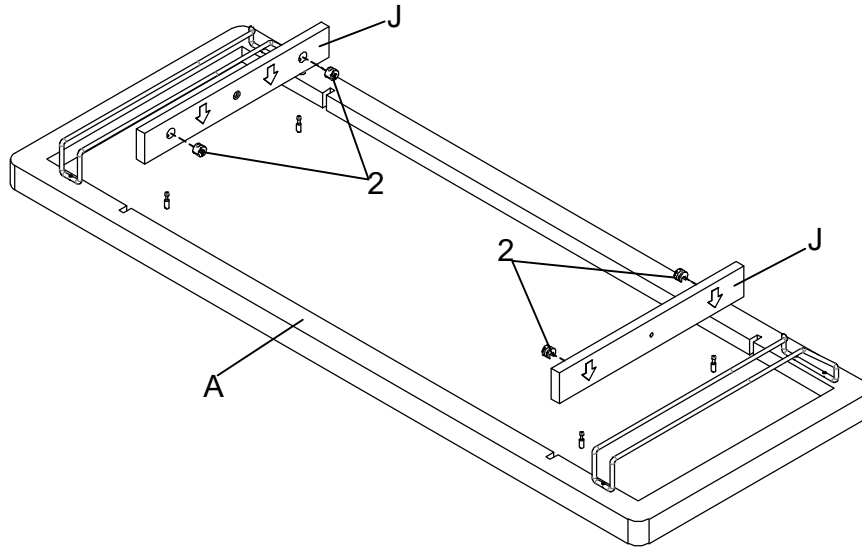

STEP 12

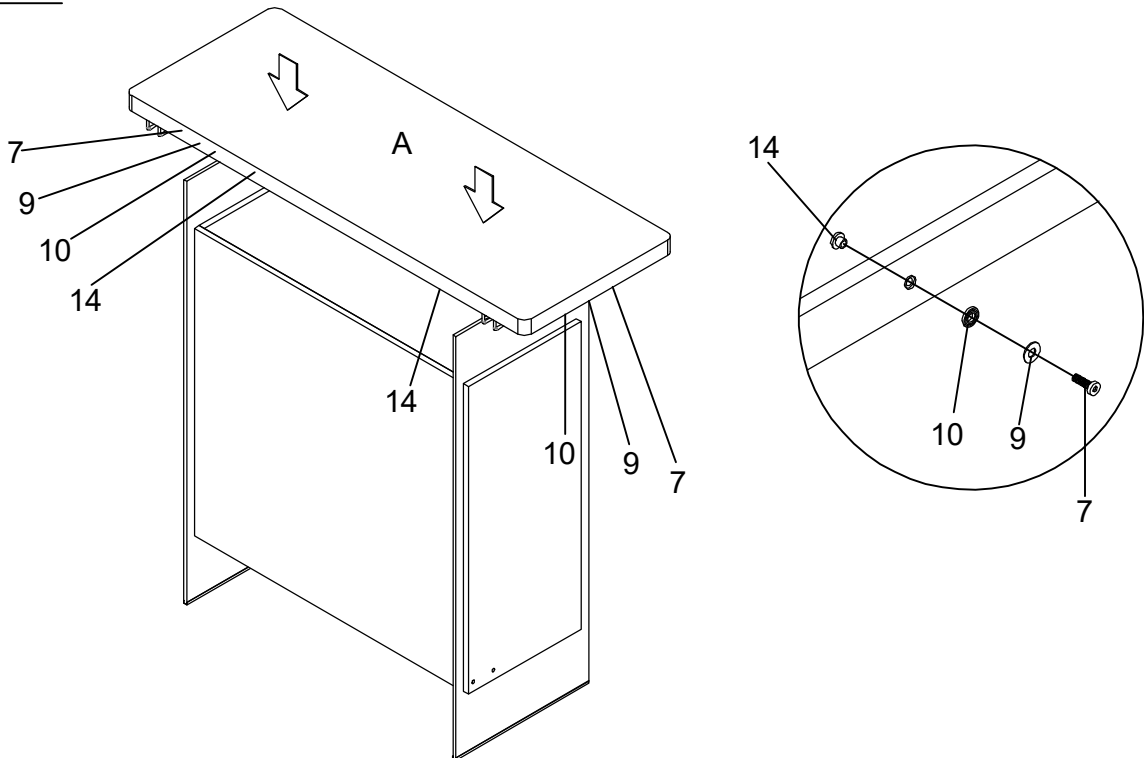

ITEM:182632

ASSEMBLY INSTRUCTIONS

STEP 13

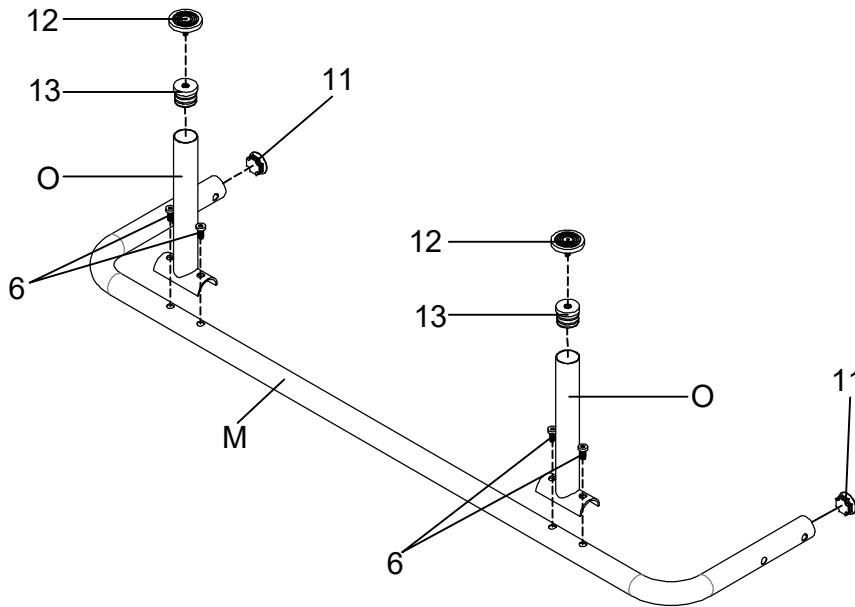

STEP 14

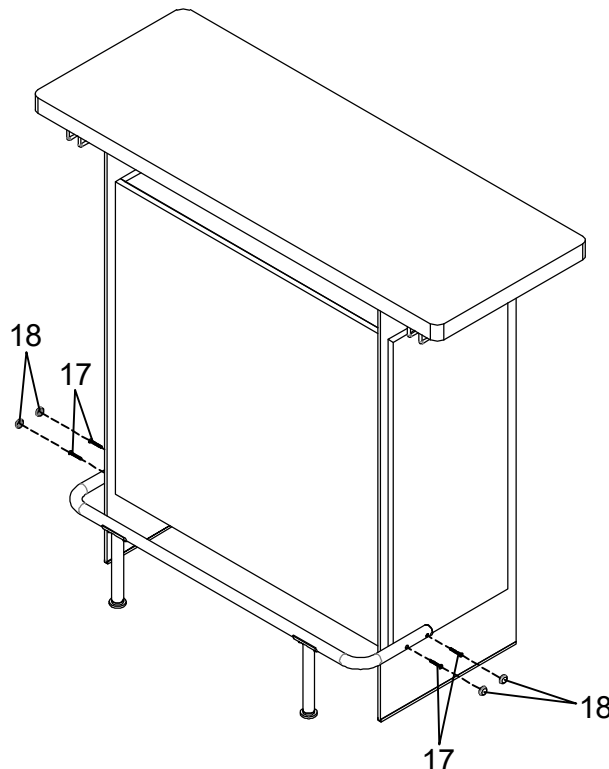

ITEM:182632

ASSEMBLY INSTRUCTIONS

STEP 15

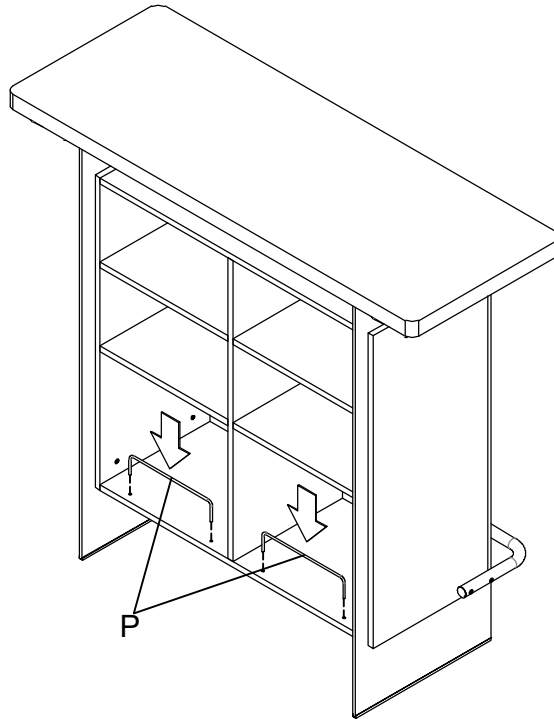

STEP 16
COMPLETE

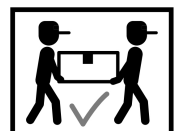
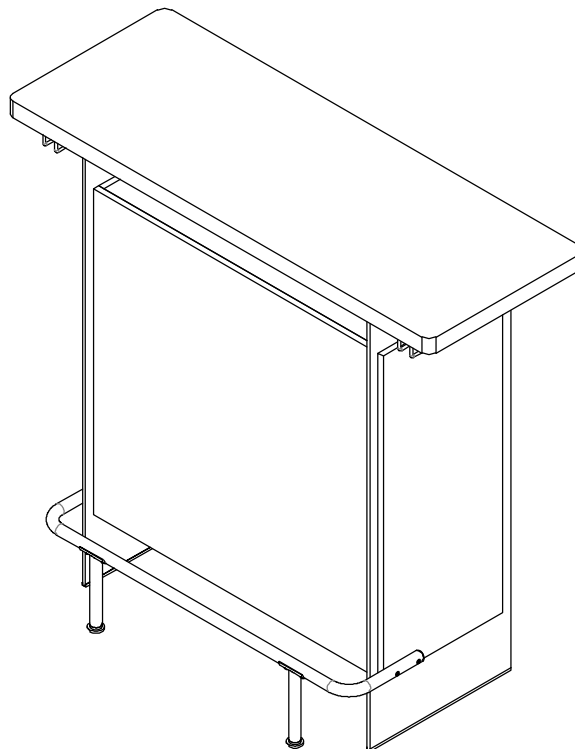

ITEM:182632 ASSEMBLY INSTRUCTIONS



Product Size : 1200 X 560 X 1120 H (MM)
Product Size : 47.25" X 22" X 44"

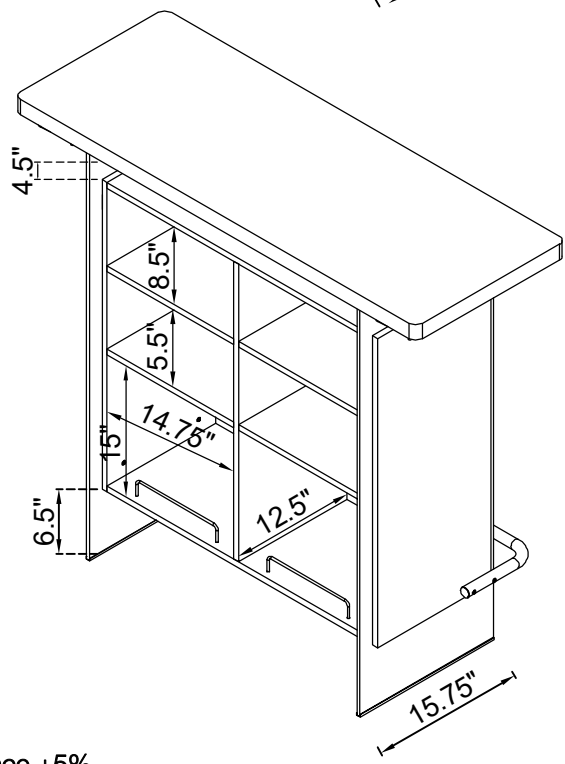
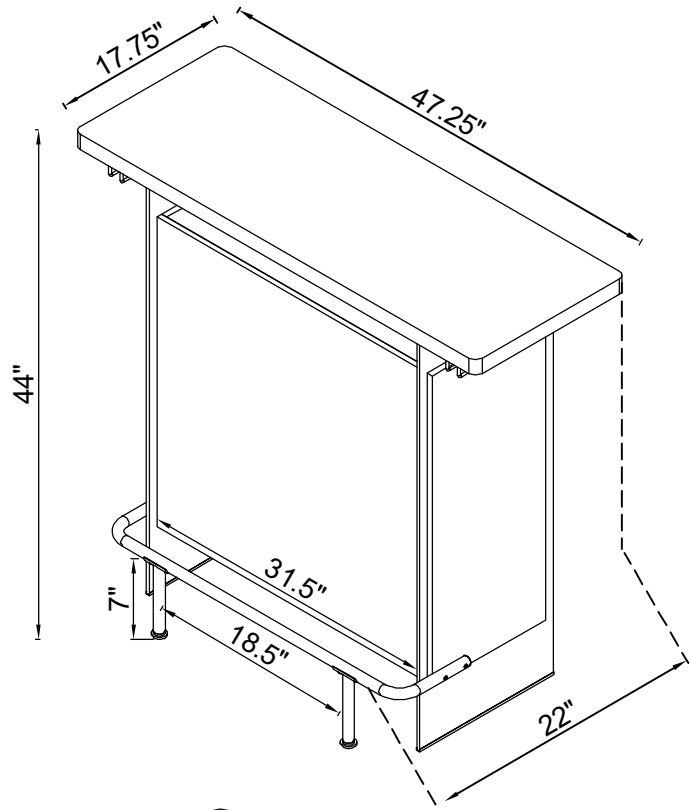

Note : Dimension tolerance $\pm 5\%$