

ASSEMBLY INSTRUCTIONS
COASTER FINE FURNITURE



Fine Furniture for every stage of life

882091
WRITING DESK

ITEM: 882091

ASSEMBLY INSTRUCTIONS

ASSEMBLY TIPS:

1. Remove hardware from box and sort by size.
2. Please check to see that all hardware and parts are present prior to start of assembly.
3. Please follow attached instructions in the same sequence as numbered to assure fast & easy assembly.



WARNING!

1. Don't attempt to repair or modify parts that are broken or defective. Please contact the store immediately.
2. This product is for home use only and not intended for commercial establishments.

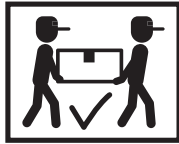

ASSEMBLY TIME

70 MINUTES











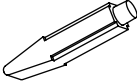

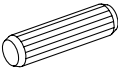

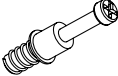

PARTS IDENTIFICATION

A	LEFT SIDE PANEL		1 PC	K	TOP PANEL		1 PC
B	RIGHT SIDE PANEL		1 PC	L	LEFT SIDE FRAME		1 PC
C	LEFT DIVIDER PANEL		1 PC	M	LEFT DRAWER FRONT SUPPORT		1 PC
D	RIGHT DIVIDER PANEL		1 PC	N	RIGHT DRAWER FRONT SUPPORT		1 PC
E	BACK PANEL		1 PC	O	FRONT TOP CROSSBAR		1 PC
F	DRAWER FRONT PANEL		2 PCS	P	BOTTOM CROSSBAR		1 PC
G	DRAWER BACK PANEL		2 PCS	Q	BACK TOP CROSSBAR		1 PC
H	DRAWER LEFT SIDE PANEL		2 PCS	R	BACK BOTTOM CROSSBAR		1 PC
I	DRAWER RIGHT SIDE PANEL		2 PCS	S	RIGHT SIDE FRAME		1 PC
J	DRAWER BOTTOM PANEL		2 PCS				

NOTE:

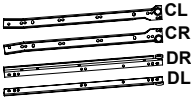
Phillips head screw driver is required in the assembly process; however, manufacturer does not provide this item.

HARDWARE IDENTIFICATION

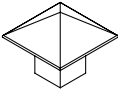
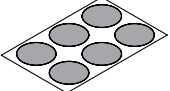
Z							
NO	DESCRIPTION	FIGURE	Q'TY	NO	DESCRIPTION	FIGURE	Q'TY
1	GLUE 15g		1 PC	10	HANDLE BOLT BLK		2 PCS
2	WOODEN DOWEL Ø8x30mm		12 PCS	11	BOLT M6x38mm BLK		12 PCS
3	CAM BOLT Ø7x35.5mm SR		8 PCS	12	BOLT M6x28mm BLK		6 PCS
4	CAM LOCK Ø15x12mm SR		8 PCS	13	SCREW Ø5x35mm BLK		2 PCS
5	SCREW Ø4.5x42mm SR		2 PCS	14	SCREW Ø5x19mm BLK		2 PCS
6	SCREW Ø4.3x35mm SR		8 PCS	15	SCREW Ø3.5x15mm BLK		16 PCS
7	RAIL L = 400mm BLK		2 SET	16	ALLEN WRENCH 4mm SR		1 PC
8	RAIL SCREW Ø3x12mm BLK		28 PCS	17	FLOOR PROTECTOR 20x20mm		4 PCS
9	HANDLE BLK		2 PCS	18	STICKER Ø20mm		2 PCS

Z7 not included in blister packaging.

NOTE:

Phillips head screw driver is required in the assembly process; however, manufacturer does not provide this item.

ITEM: 882091

COASTER
FINE FURNITURE

STEP 1

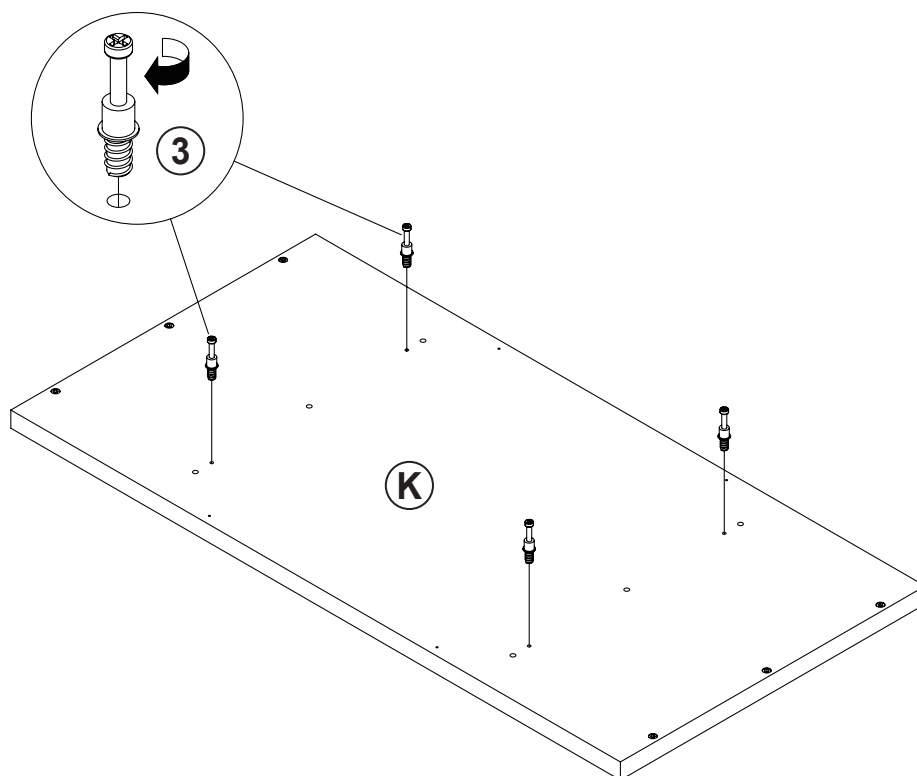
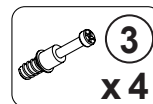

STEP 2

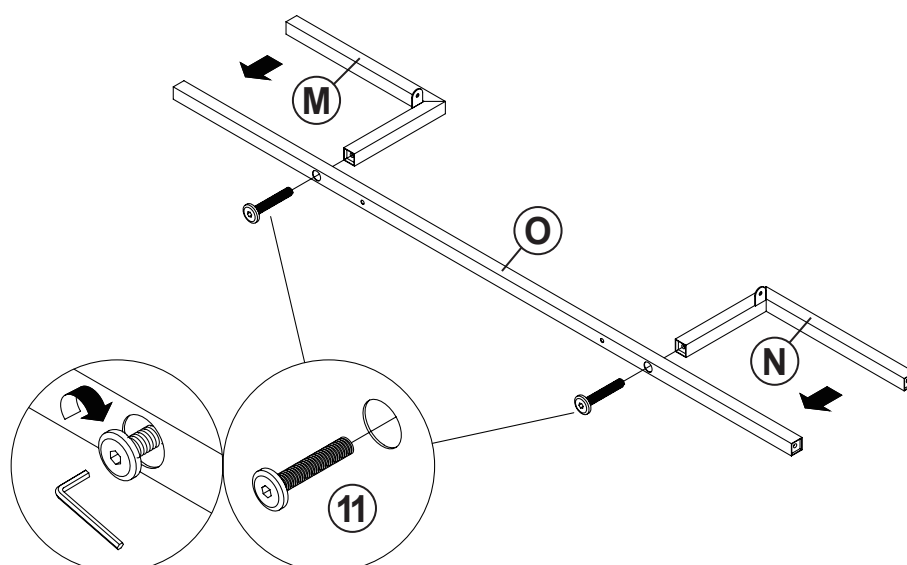

ITEM: **882091**

COASTER
FINE FURNITURE

STEP 3

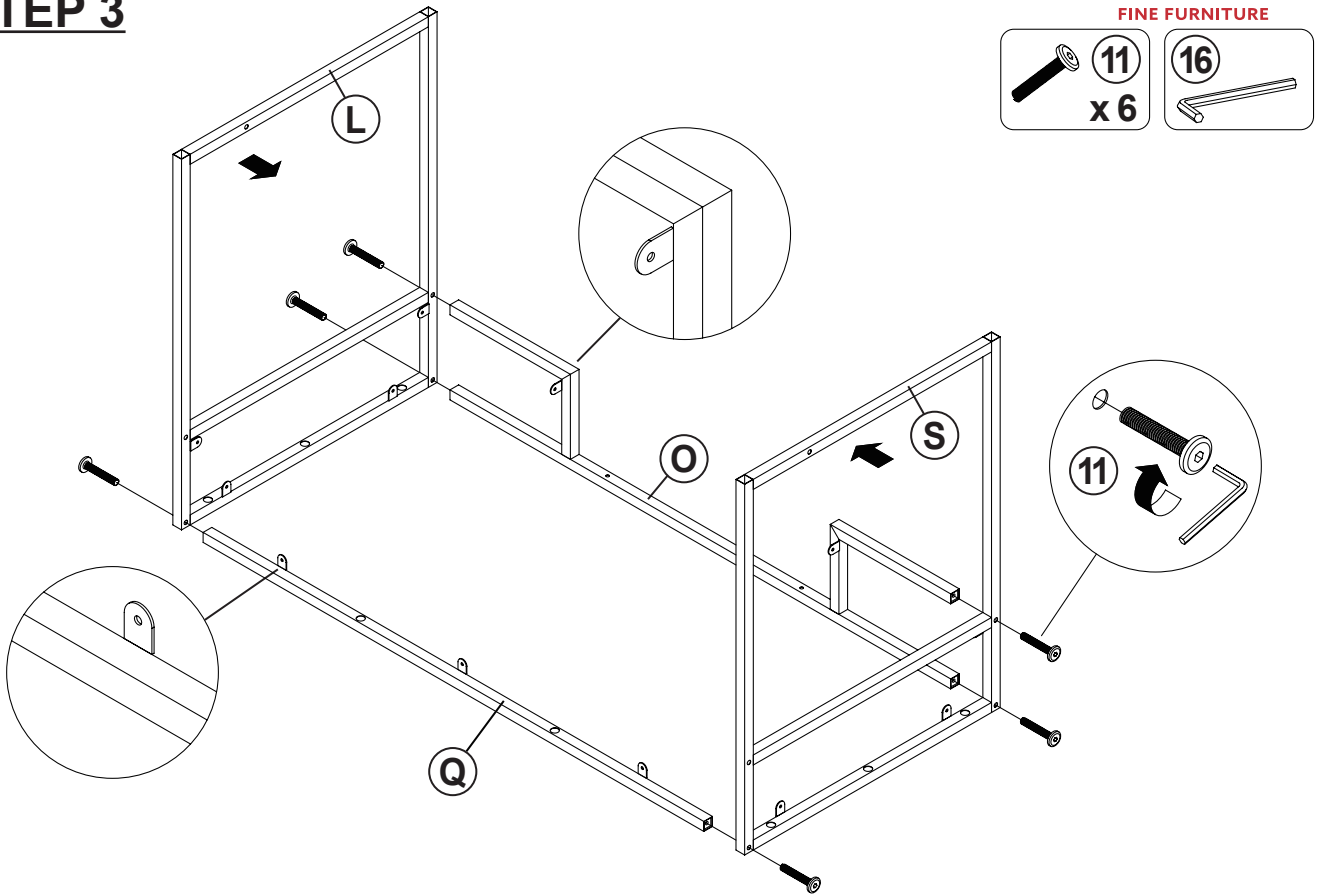

STEP 4

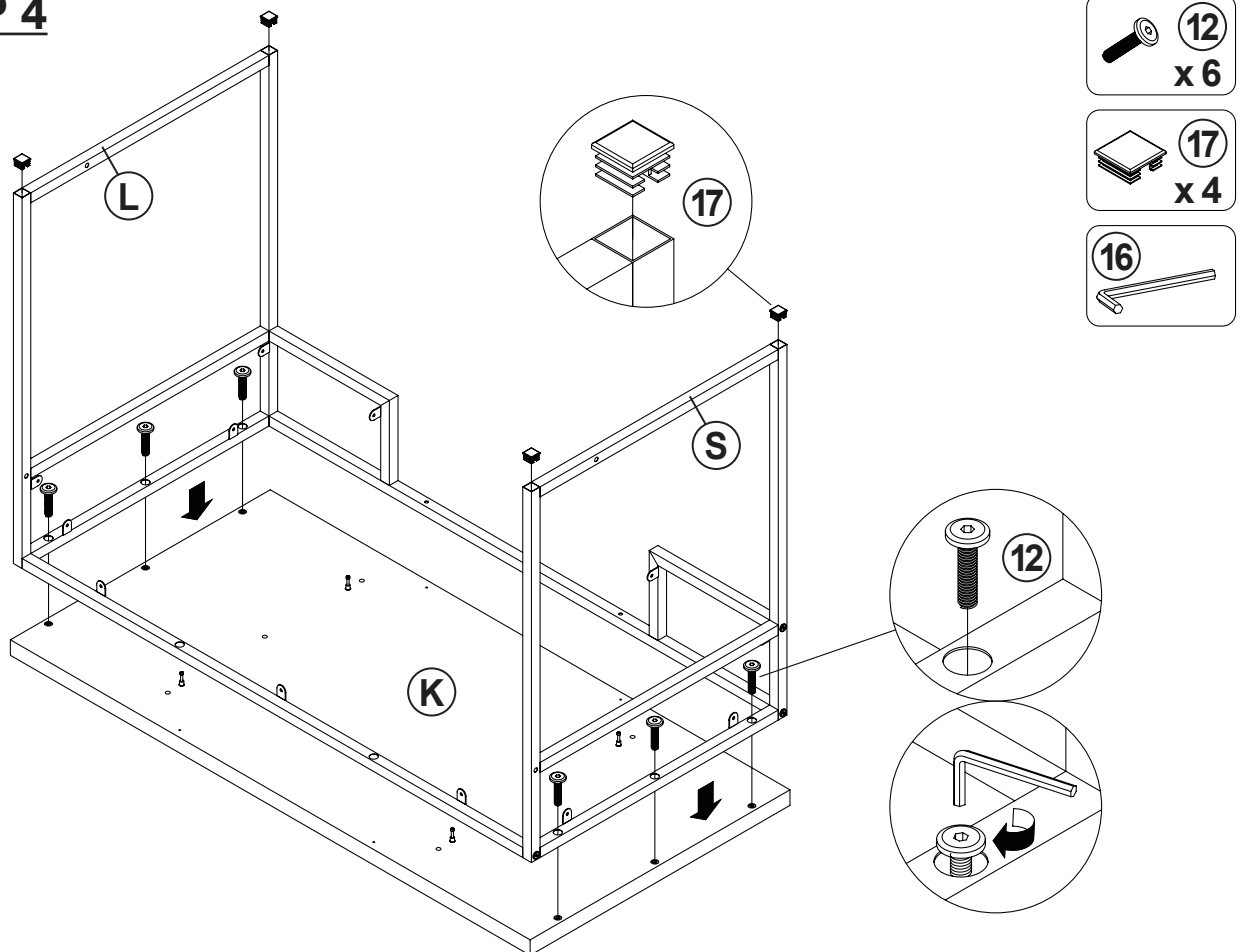

ITEM: 882091

COASTER
FINE FURNITURE

STEP 5

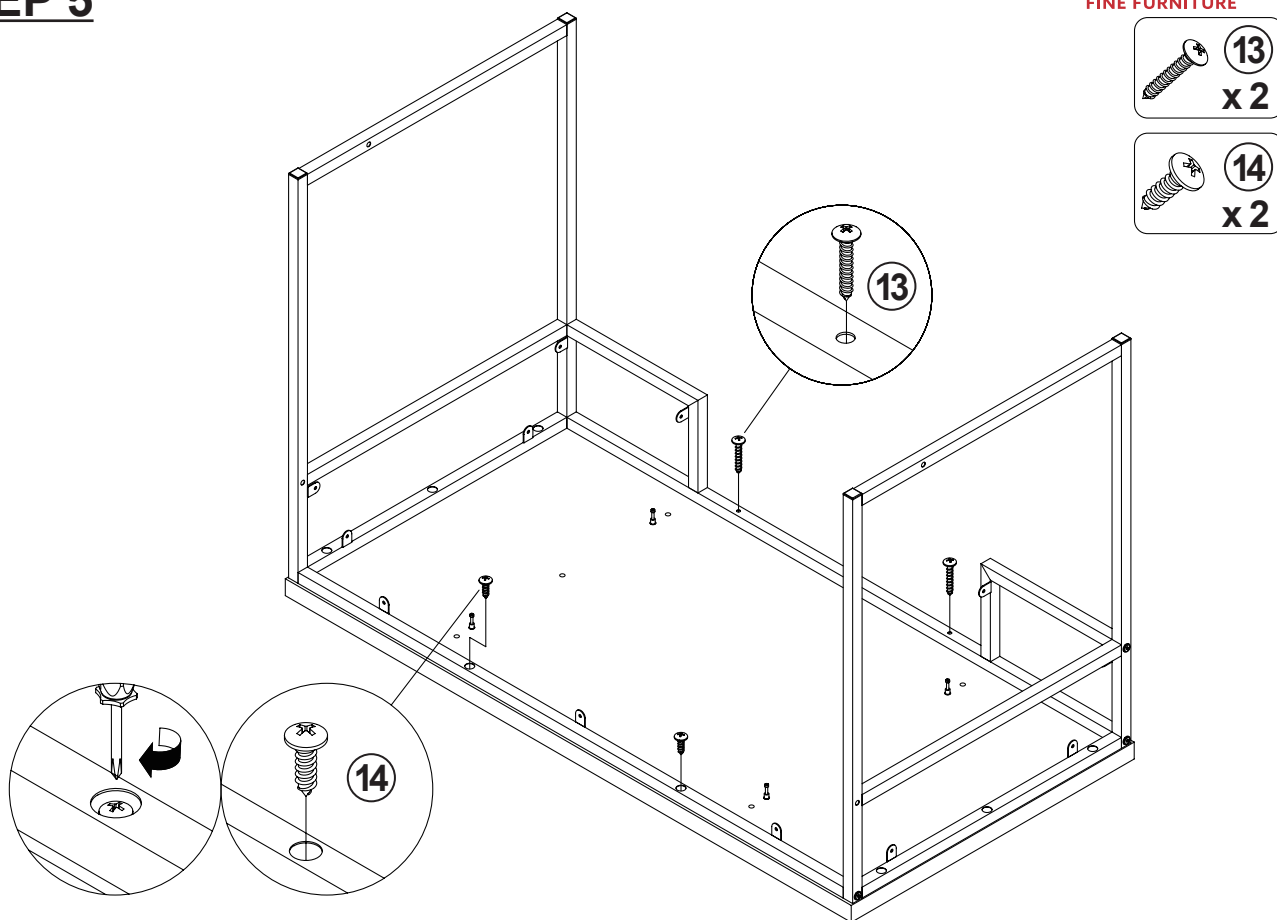

STEP 6

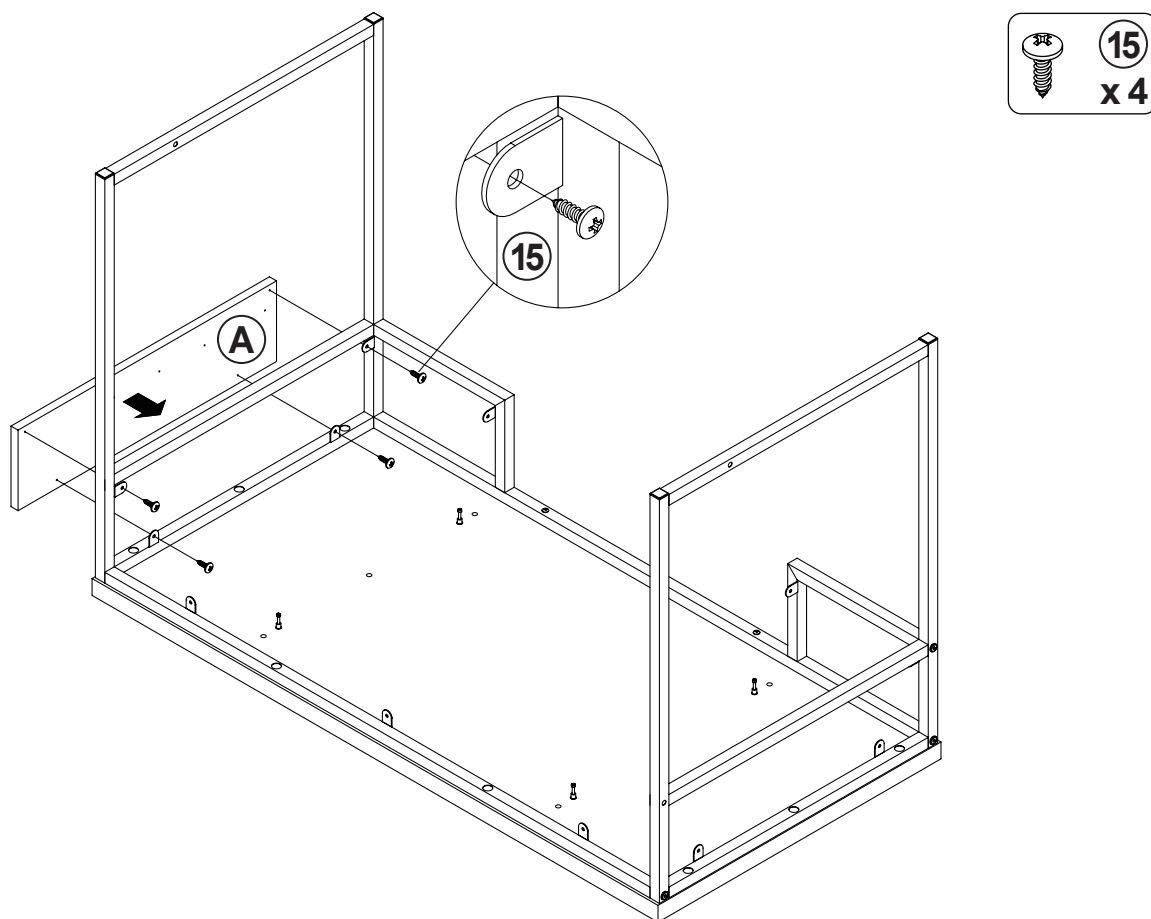

ITEM: **882091**

COASTER[®]

FINE FURNITURE

STEP 7

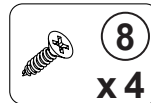
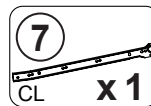
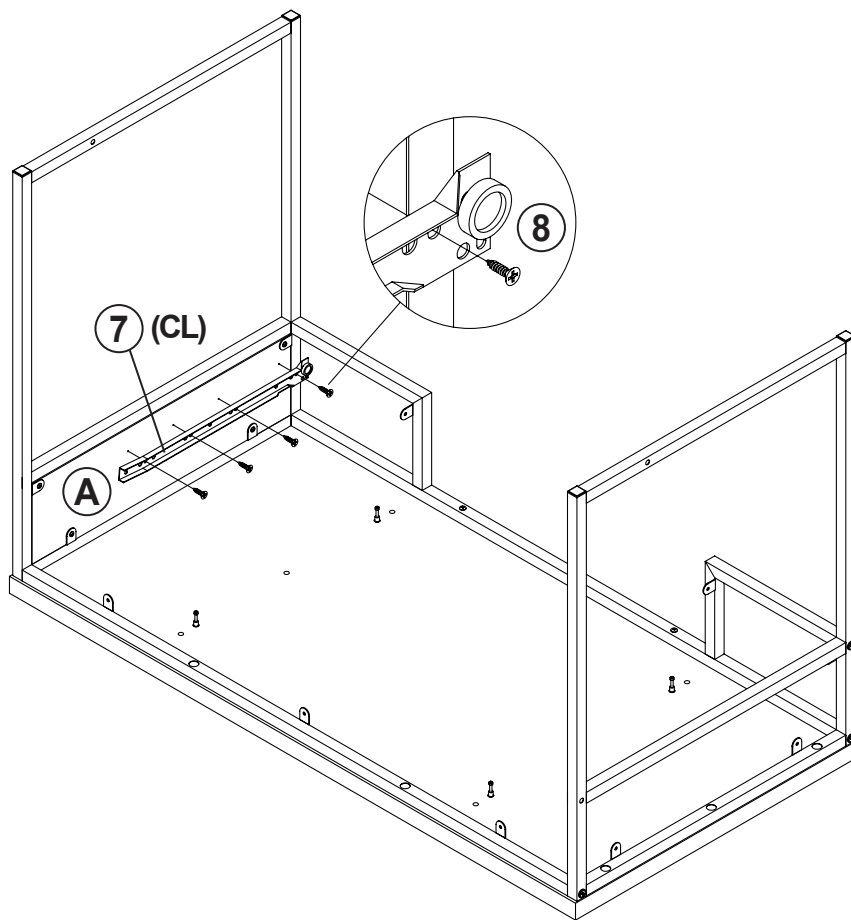

STEP 8

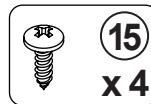
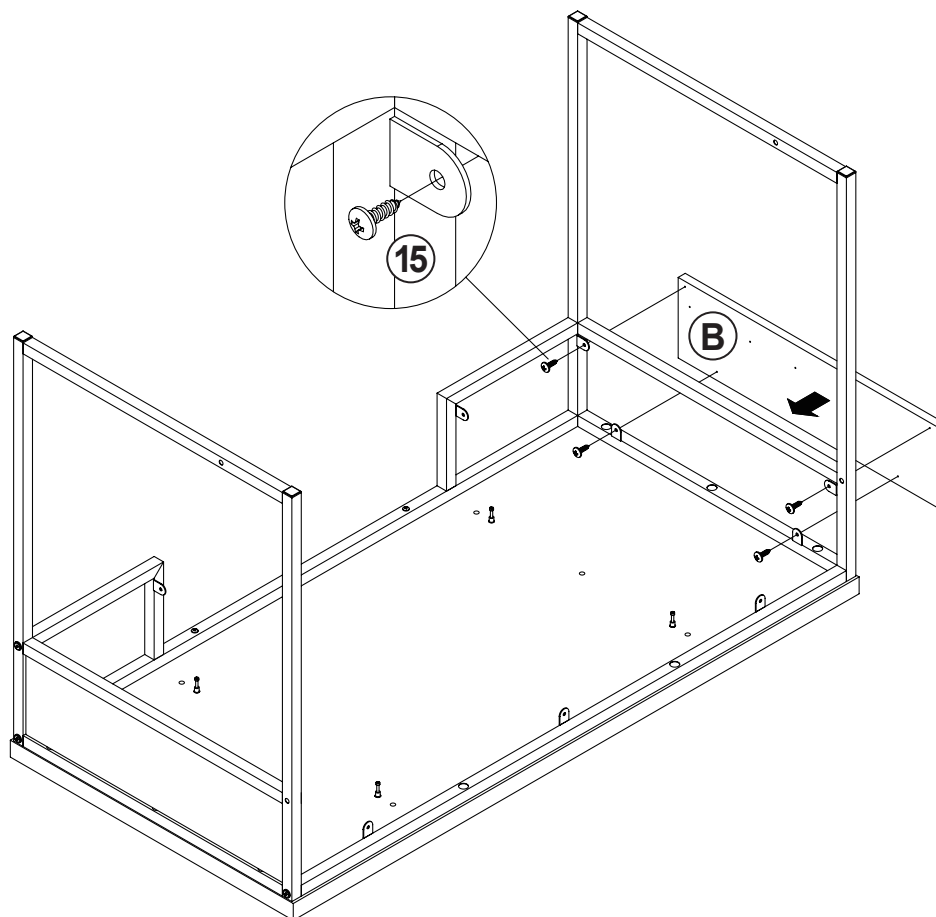

ITEM: **882091**

COASTER[®]

FINE FURNITURE

STEP 9

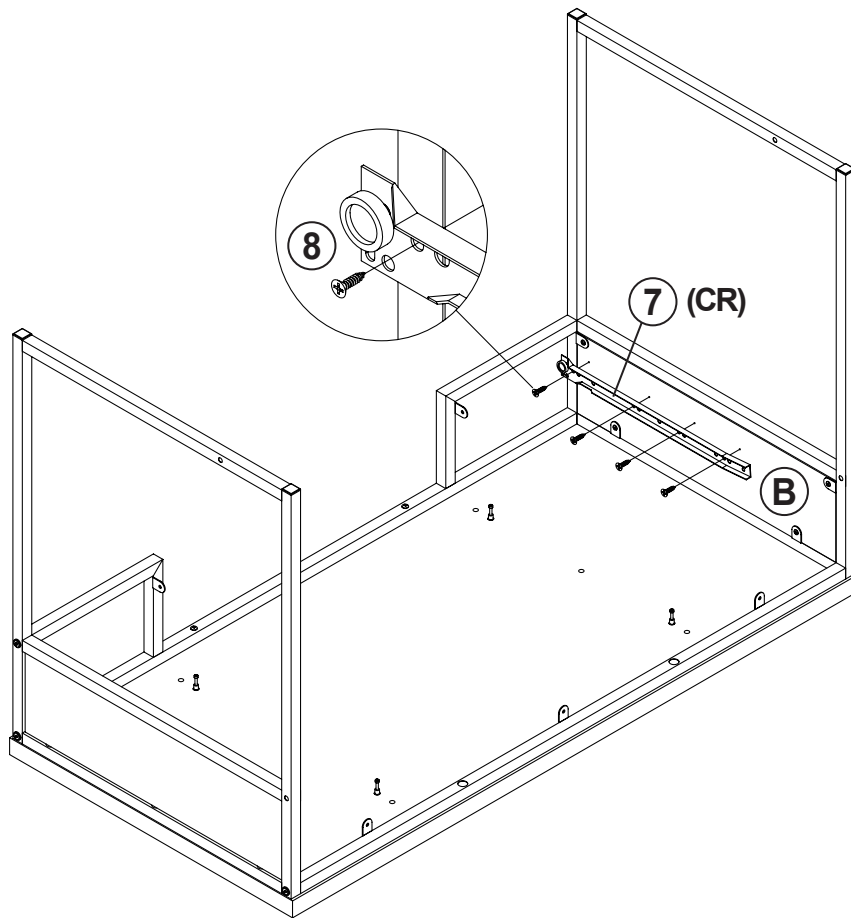
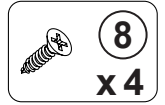
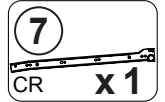

STEP 10

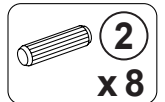

INCORRECT
CORRECT

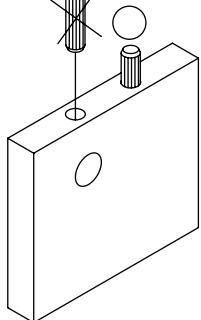

Apply glue on all wooden dowels to ensure integrity of the structure.

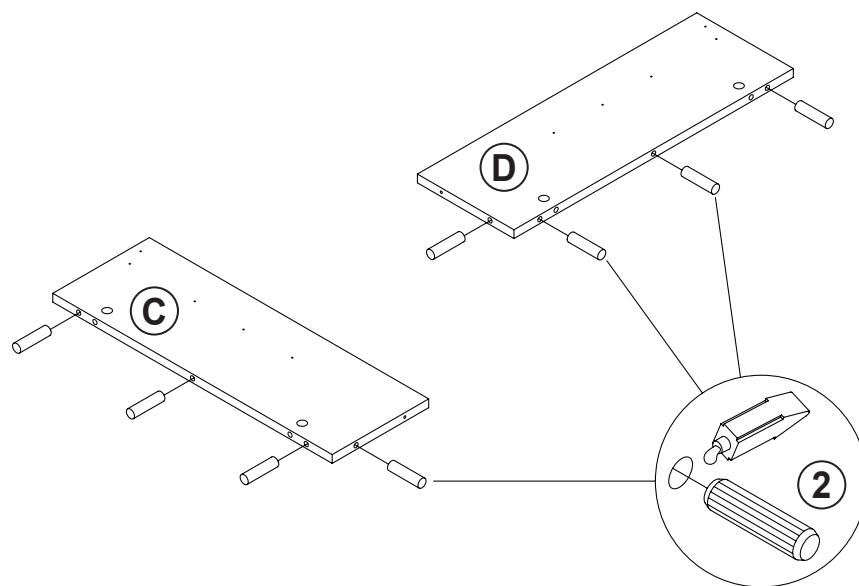

ITEM: **882091**

COASTER[®]

FINE FURNITURE

STEP 13

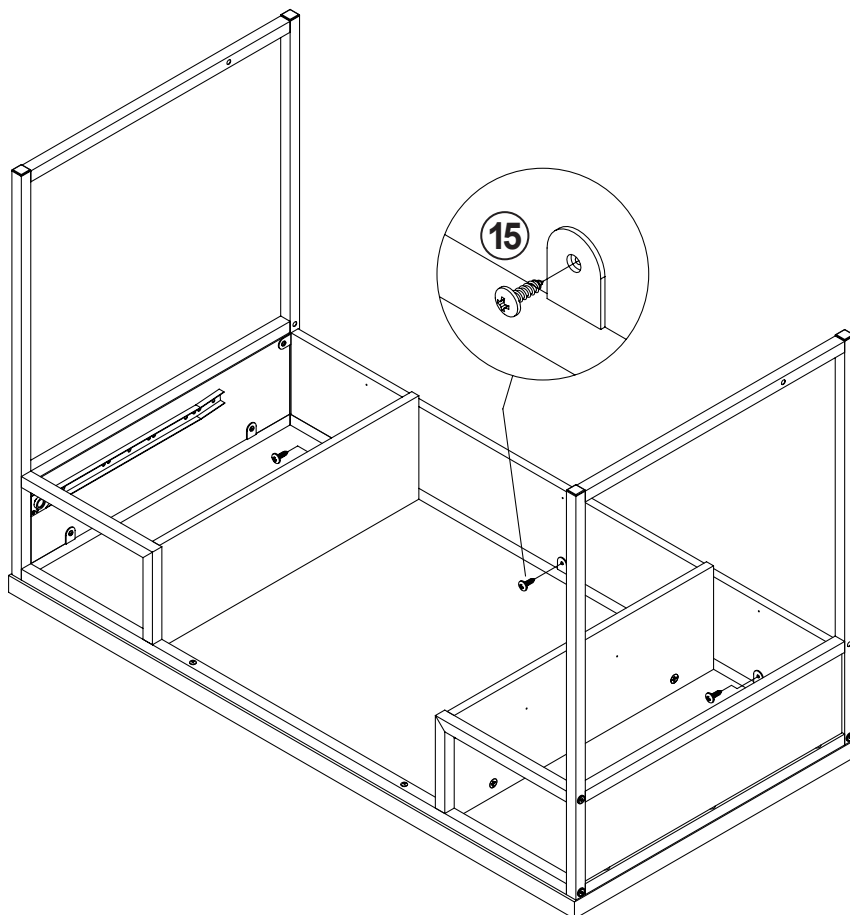
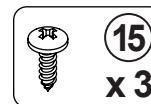

STEP 14

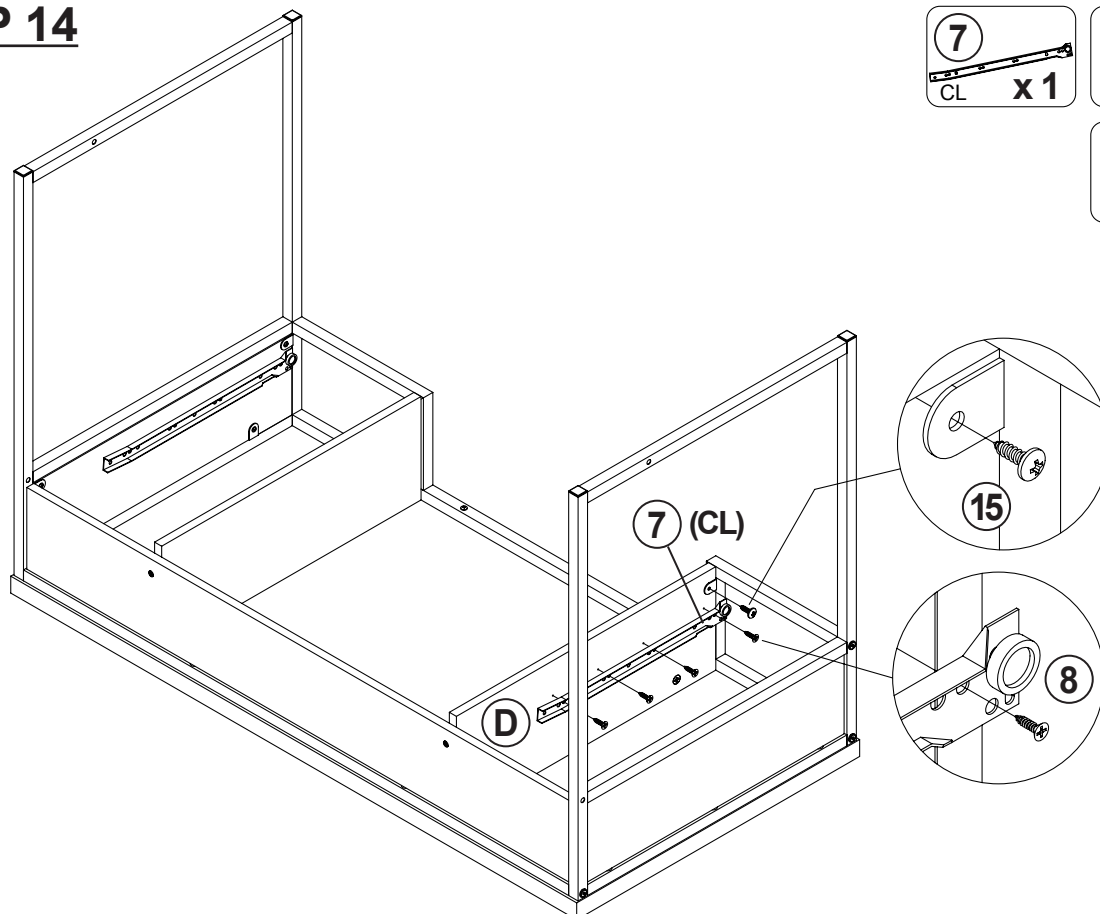
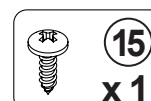
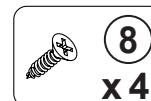
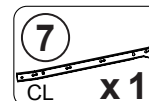

ITEM: **882091**

COASTER
FINE FURNITURE

STEP 15

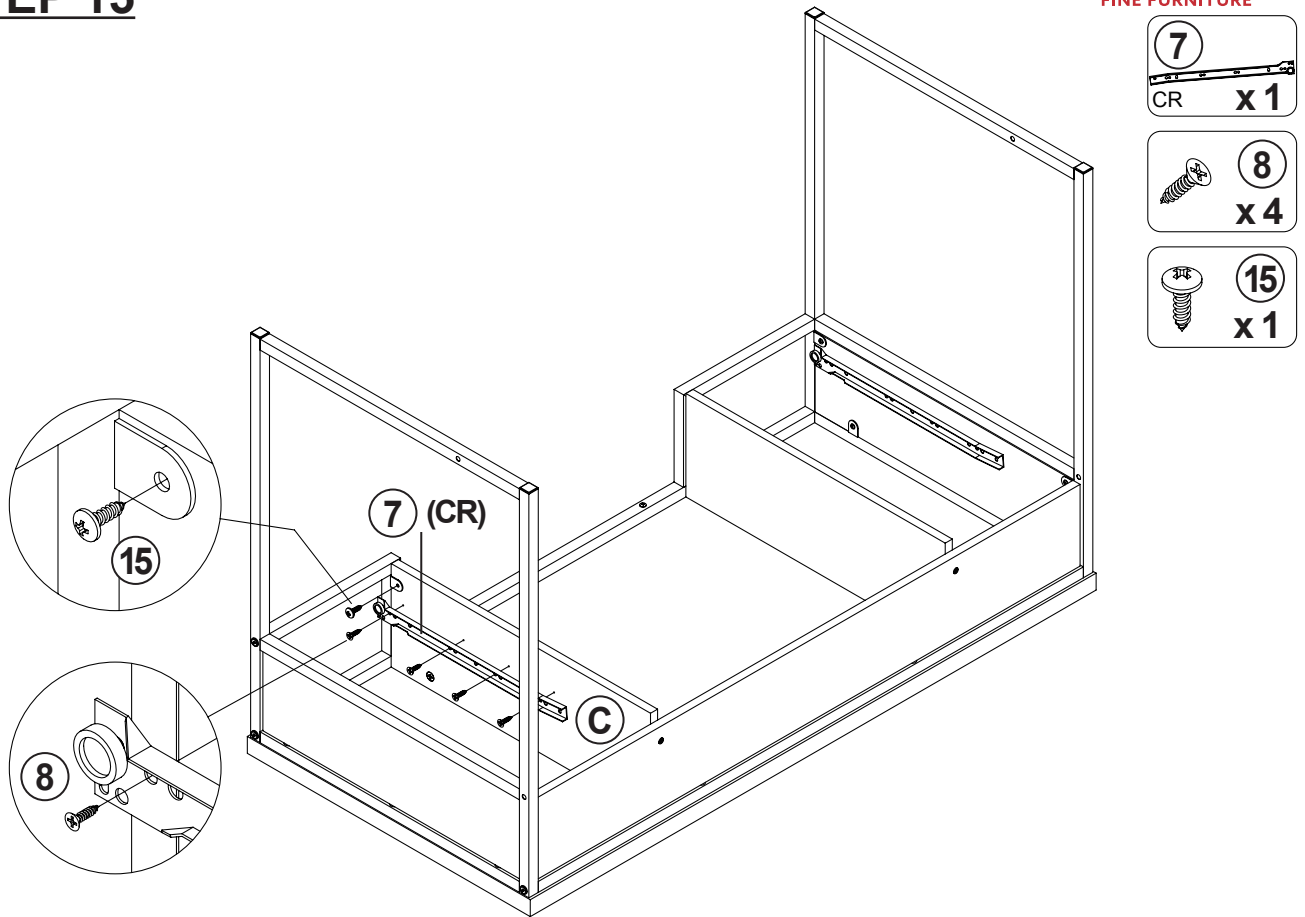

STEP 16

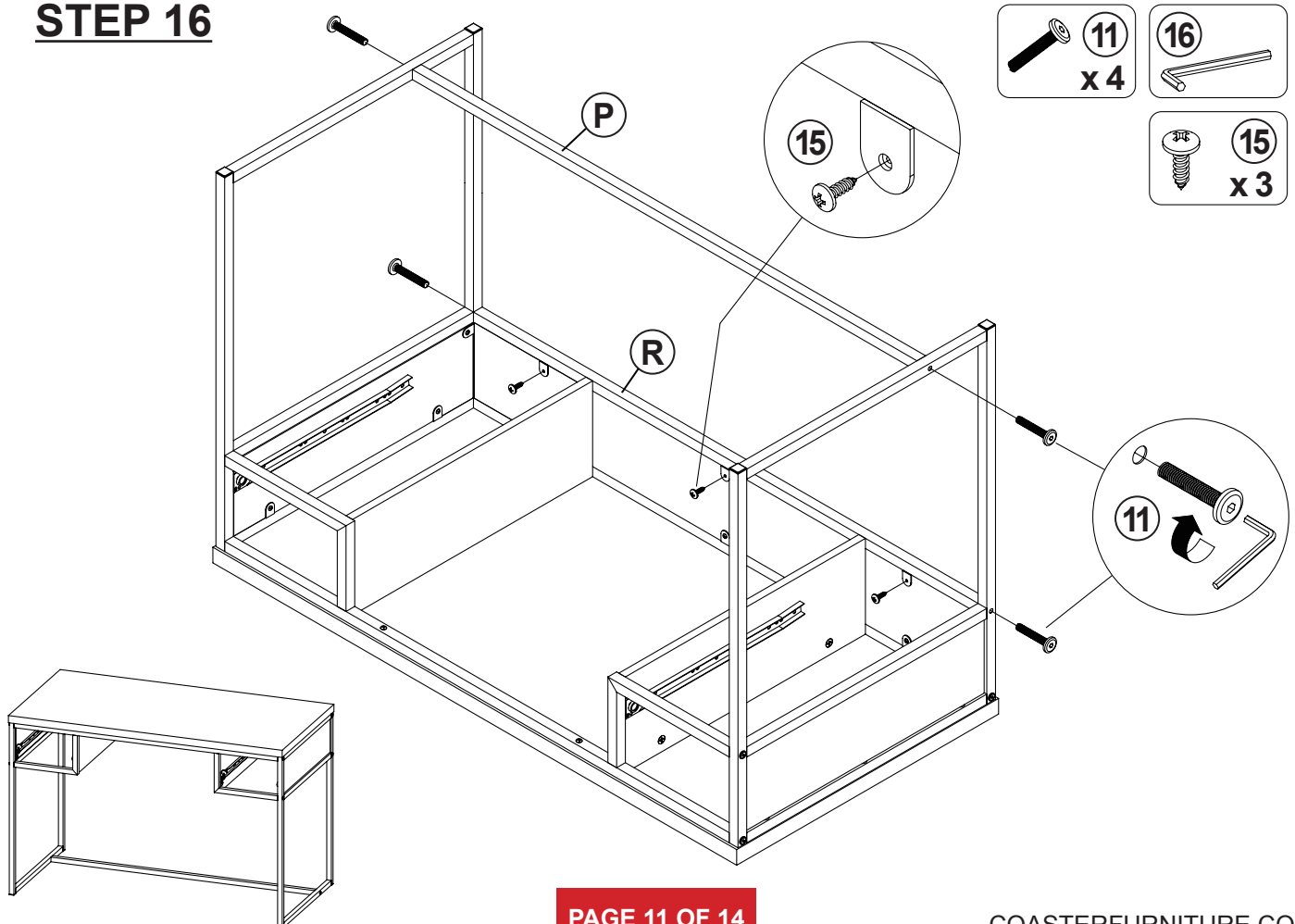

ITEM: 882091

STEP 17-1

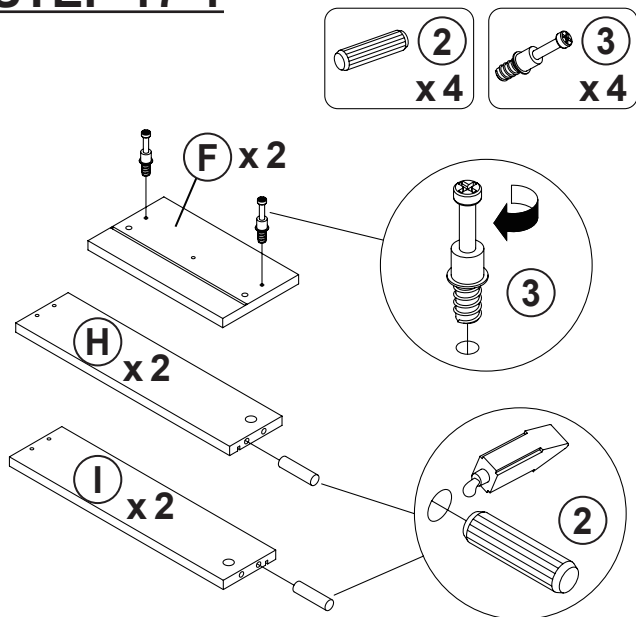

STEP 17-2

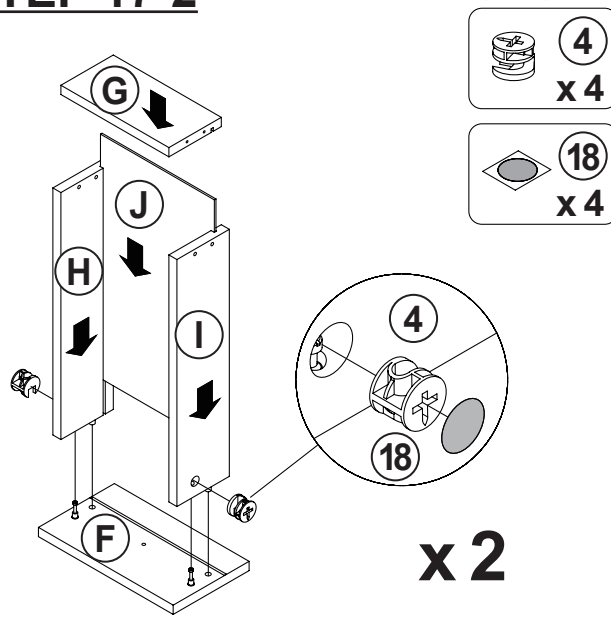

STEP 17-3

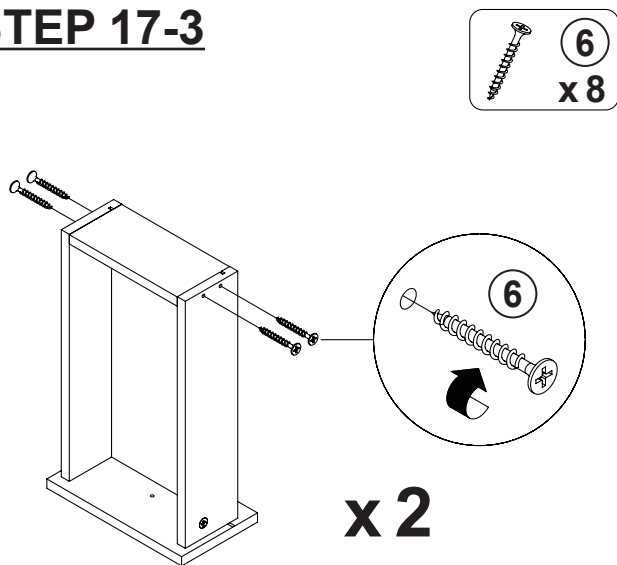

STEP 17-4

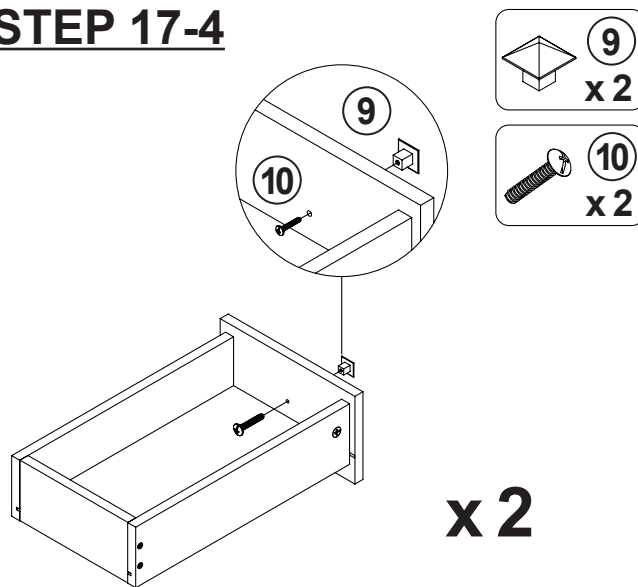

STEP 17-5

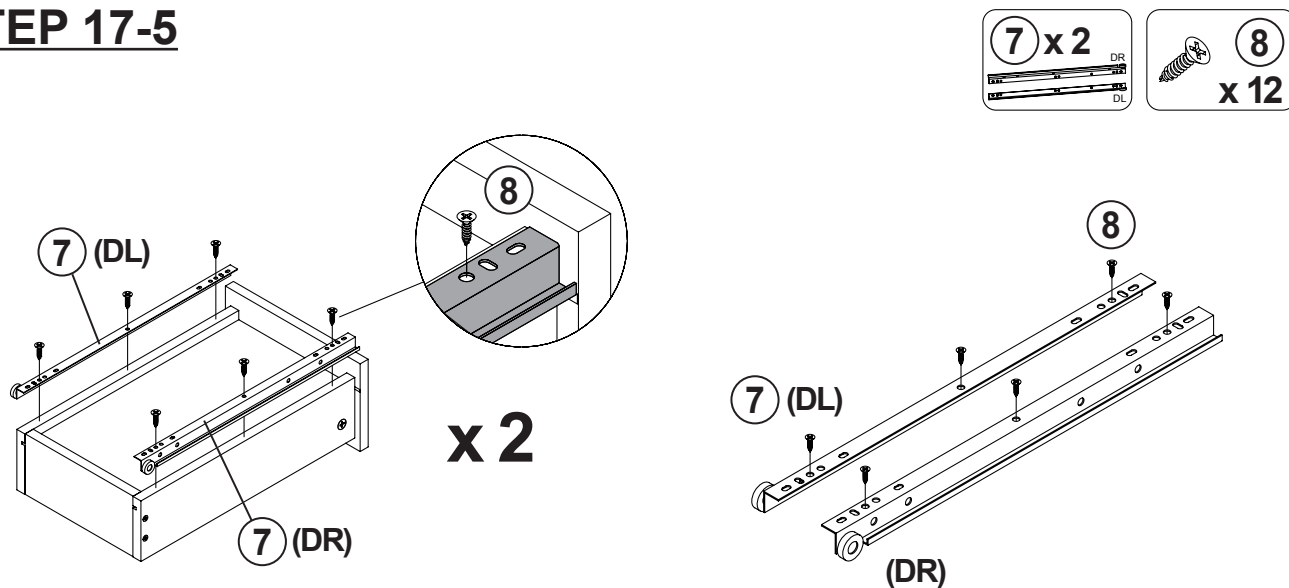

ITEM: **882091**

STEP 18

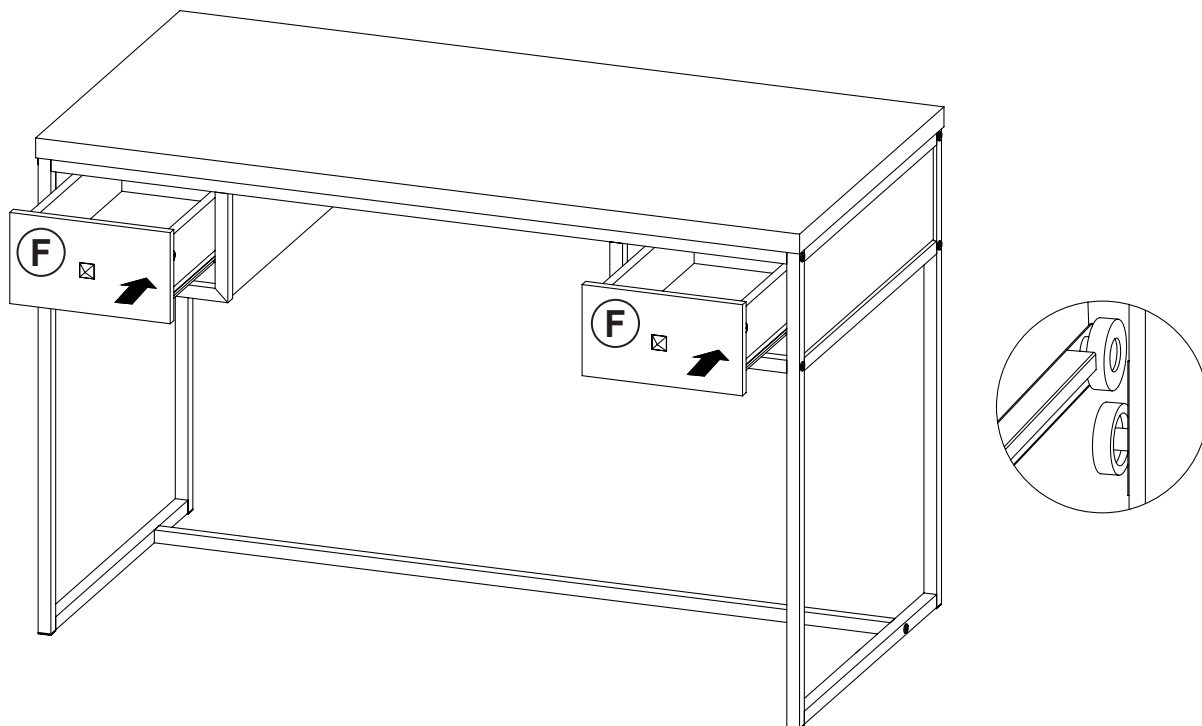

STEP 19
COMPLETE

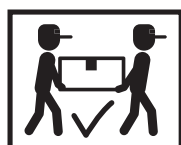
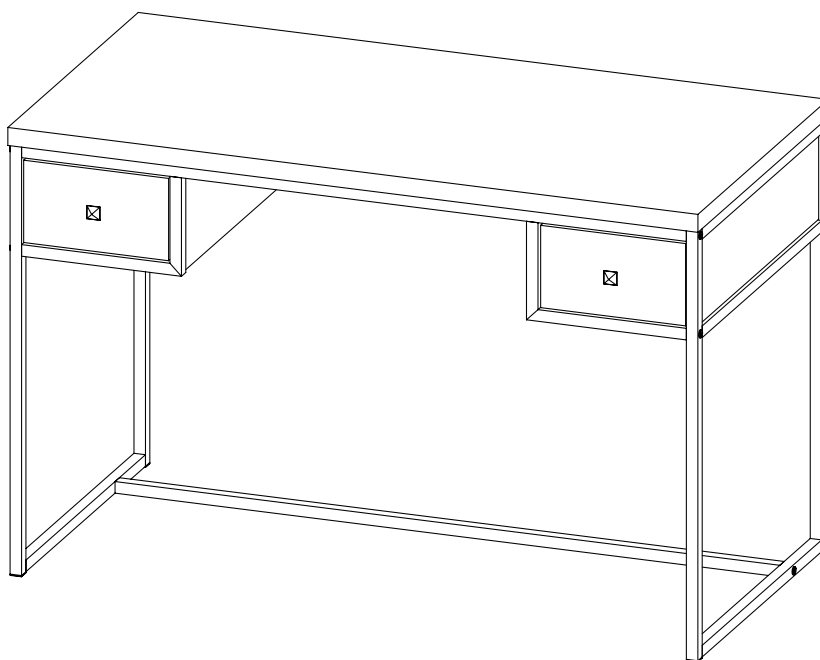

ITEM: 882091

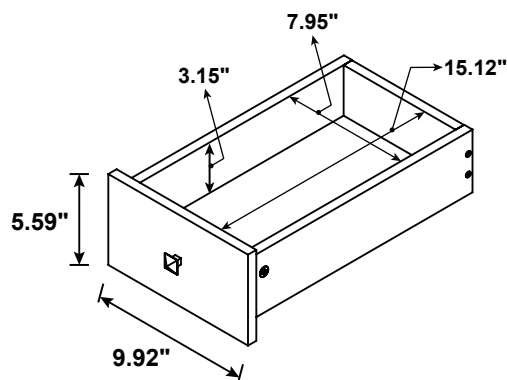
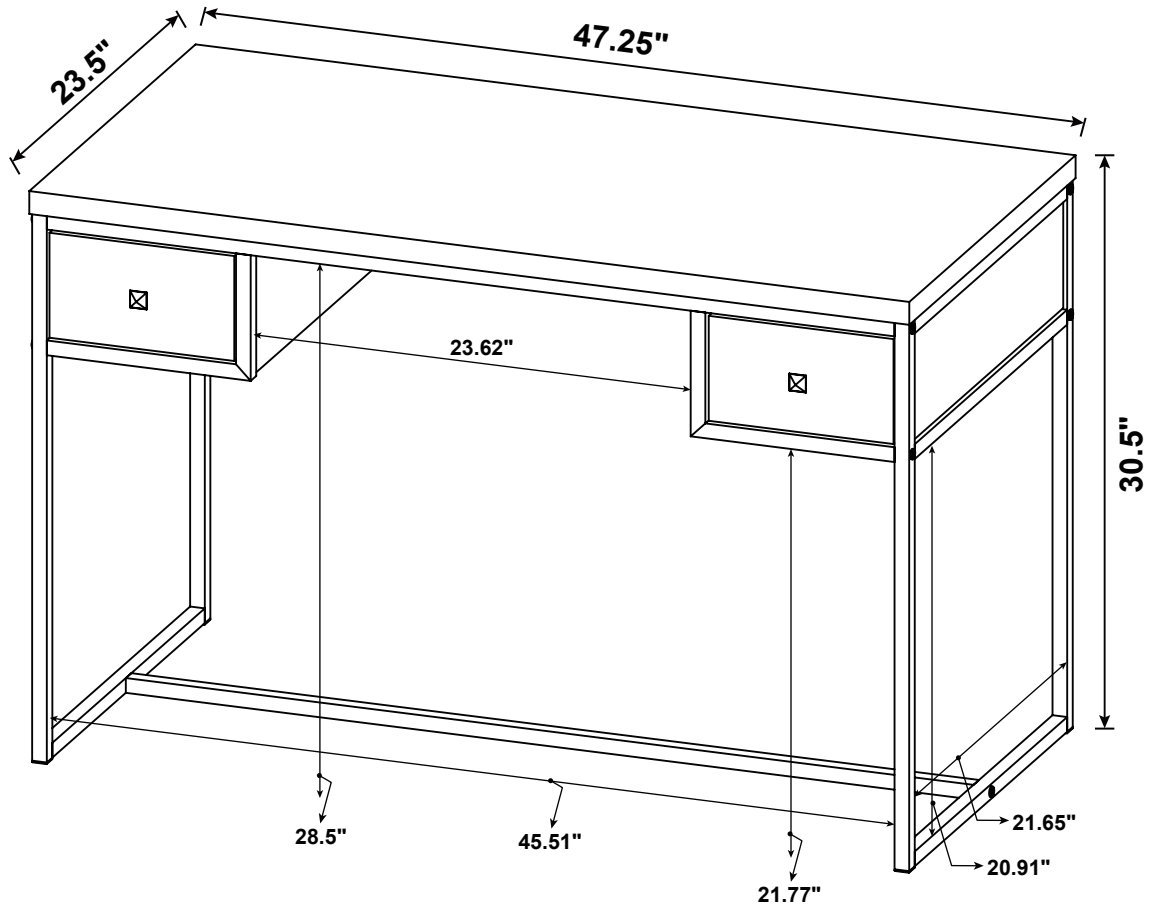

Note : Dimension tolerance $\pm 5\%$