

*ASSEMBLY INSTRUCTIONS*  
*COASTER FINE FURNITURE*



*Fine Furniture for every stage of life*

**801504**  
**WRITING DESK**

REVISION 0 : 09/20/2017  
REVISION 1 : 07/13/2022

ITEM:801504



# ASSEMBLY INSTRUCTIONS

## ASSEMBLY TIPS:

1. Remove hardware from box and sort by size.
2. Please check to see that all hardware and parts are present prior to start of assembly.
3. Please follow attached instructions in the same sequence as numbered to assure fast & easy assembly.







### WARNING!

1. Don't attempt to repair or modify parts that are broken or defective. Please contact the store immediately.
2. This product is for home use only and not intended for commercial establishments.



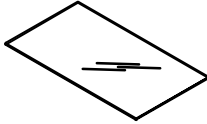

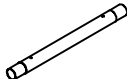



ASSEMBLY TIME 25 MINUTES

## PARTS IDENTIFICATION

A	TOP GLASS		1PC
B	SIDE FRAME		4PCS
C	TOP CROSSBAR		2PCS
D	BOTTOM CROSSBAR		2PCS

## HARDWARE IDENTIFICATION

1	CAP ( $\phi$ 2")		4PCS	4	SUCTION CUP (8mm)		4PCS
2	LONG BOLT (1/4" x 50mm SR)		4PCS	5	LEVELER (1/4" x 18mm)		8PCS
3	SHORT BOLT (1/4" x 15mm SR)		8PCS	6	ALLEN WRENCH (4mm)		1PC

# ITEM: 801504 ASSEMBLY INSTRUCTIONS



**STEP 1** Do not tighten until each step is completed or instructed.

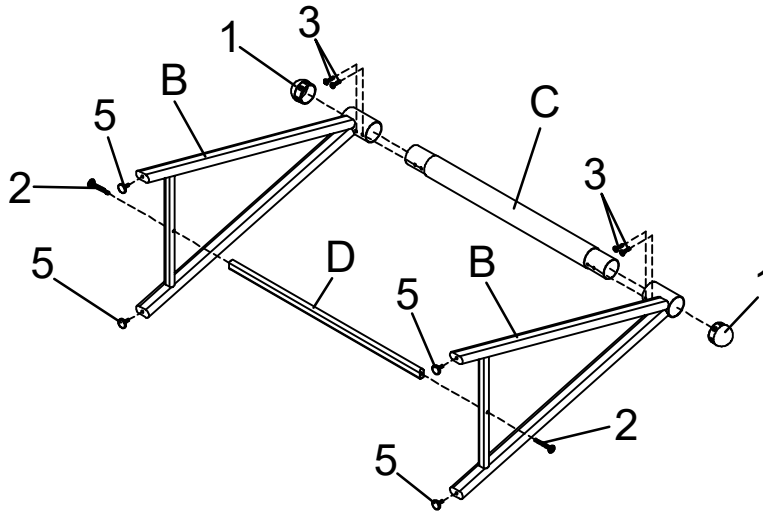

## STEP 2

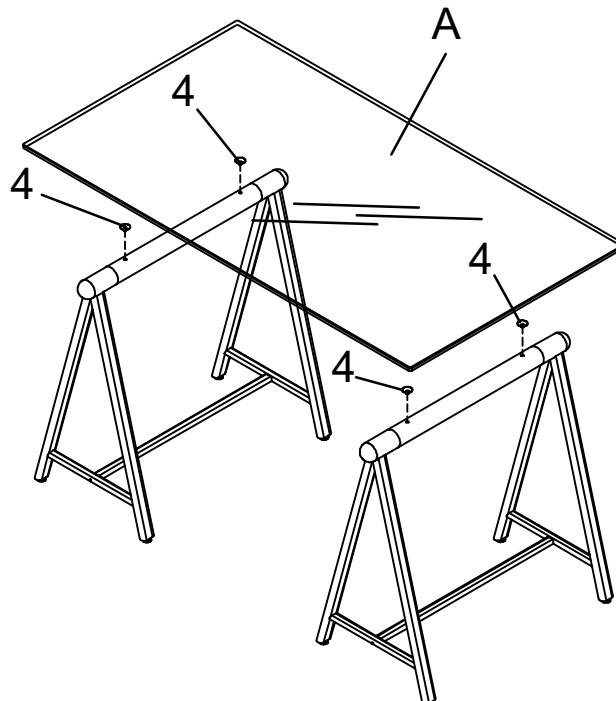

COMPLETE

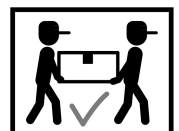
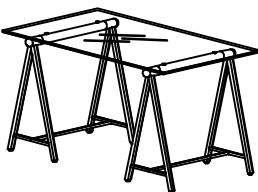

# ITEM:801504 ASSEMBLY INSTRUCTIONS



Product Size : 1500 X 800 X 776 H (MM)
Product Size : 59" X 31 1/2" X 30 1/2"

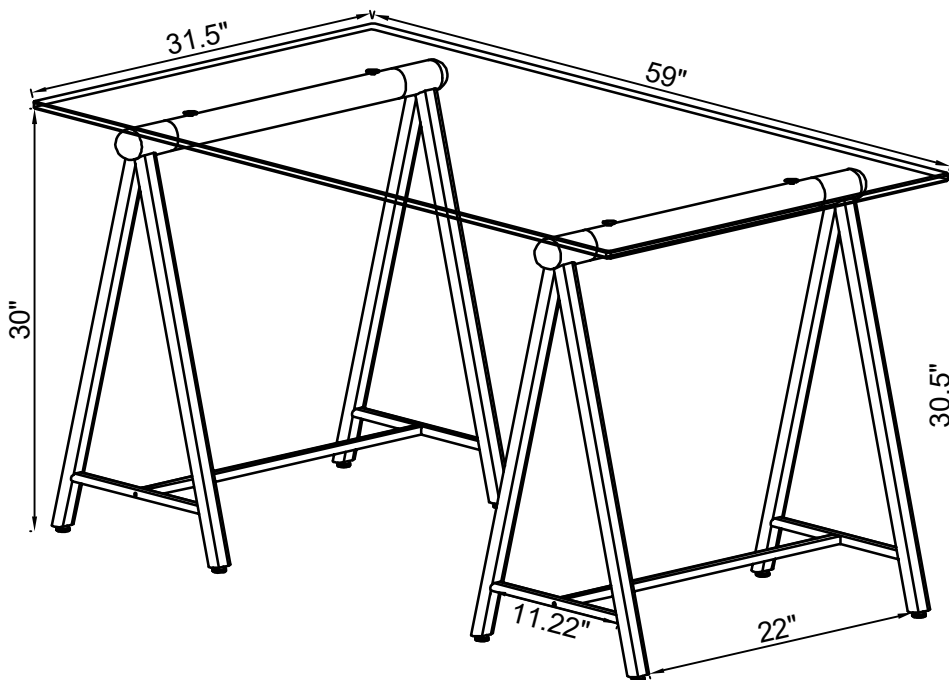

Note : Dimension tolerance  $\pm 5\%$