

ASSEMBLY INSTRUCTIONS
COASTER FINE FURNITURE



Fine Furniture for every stage of life

801950
OFFICE DESK

ITEM: 801950



ASSEMBLY INSTRUCTIONS

ASSEMBLY TIPS:

1. Remove hardware from box and sort by size.
2. Please check to see that all hardware and parts are present prior to start of assembly.
3. Please follow attached instructions in the same sequence as numbered to assure fast & easy assembly.



WARNING!

1. Don't attempt to repair or modify parts that are broken or defective. Please contact the store immediately.
2. This product is for home use only and not intended for commercial establishments.

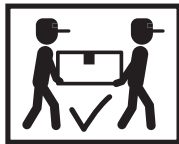

ASSEMBLY TIME

60 MINUTES





PARTS IDENTIFICATION

| | | | | | | | |
|---|---------------------|--|-------|---|-------------------------------|--|------|
| A | LEFT SIDE PANEL | | 1 PC | H | TOP | | 1 PC |
| B | RIGHT SIDE PANEL | | 1 PC | I | DOOR | | 1 PC |
| C | LEFT DIVIDER PANEL | | 1 PC | J | LARGE DRAWER FRONT PANEL | | 1 PC |
| D | RIGHT DIVIDER PANEL | | 1 PC | K | LARGE DRAWER BACK PANEL | | 1 PC |
| E | BOTTOM PANEL | | 2 PCS | L | LARGE LEFT DRAWER SIDE PANEL | | 1 PC |
| F | CROSS PANEL | | 1 PC | M | LARGE RIGHT DRAWER SIDE PANEL | | 1 PC |
| G | BACK PANEL | | 1 PC | N | LARGE DRAWER BOTTOM PANEL | | 1 PC |

NOTE:

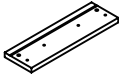
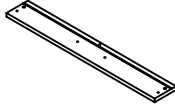
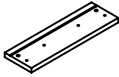
Phillips head screw driver is required in the assembly process; however, manufacturer does not provide this item.

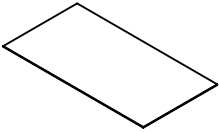
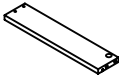
ITEM: 801950

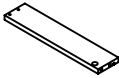
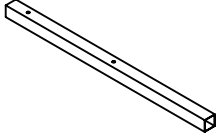
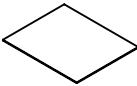
| | | | | | | | |
|---|----------------------------------------|-------------------------------------------------------------------------------------|-------|----|-------------------------------------|--------------------------------------------------------------------------------------|-------|
| O | SMALL LEFT DRAWER FRONT PANEL |  | 1 PC | U | MIDDLE DRAWER FRONT PANEL |  | 1 PC |
| P | SMALL RIGHT DRAWER FRONT PANEL |  | 1 PC | V | MIDDLE DRAWER BACK PANEL |  | 1 PC |
| Q | SMALL DRAWER BACK PANEL |  | 2 PCS | A1 | MIDDLE DRAWER BOTTOM PANEL |  | 1 PC |
| R | SMALL LEFT DRAWER SIDE PANEL |  | 3 PCS | B1 | DRAWER SUPPORT |  | 1 PC |
| S | SMALL RIGHT DRAWER SIDE PANEL |  | 3 PCS | C1 | LEG |  | 4 PCS |
| T | SMALL DRAWER BOTTOM PANEL |  | 2 PCS | | | | |

NOTE:

Phillips head screw driver is required in the assembly process; however, manufacturer does not provide this item.

ITEM: 801950

HARDWARE IDENTIFICATION

| Z | | | | | | | |
|----|-----------------------------|--------|--------|----|-----------------------------|--------|--------|
| NO | DESCRIPTION | FIGURE | Q'TY | NO | DESCRIPTION | FIGURE | Q'TY |
| 1 | GLUE 40g | | 1 PC | 11 | HANDLE L = 137.5mm | | 5 PCS |
| 2 | WOODEN DOWEL Ø 8x30mm | | 50 PCS | 12 | HANDLE BOLT Ø 4x28mm BLK | | 10 PCS |
| 3 | CAM BOLT Ø 7x35.5mm SR | | 32 PCS | 13 | HINGE Ø 35mm SR | | 2 PCS |
| 4 | CAM LOCK Ø 15x12mm SR | | 32 PCS | 14 | HINGE SCREW Ø 4x15mm SR) | | 8 PCS |
| 5 | LONG SCREW Ø 4.5x42mm SR | | 8 PCS | 15 | BOLT M 6x28mm BLK | | 8 PCS |
| 6 | SCREW Ø 4.3x35mm SR | | 17 PCS | 16 | ALLEN WRENCH 4mm SR | | 1PC |
| 7 | DOOR CATCH | | 1 PC | 17 | FLOOR PROTECTOR 38x38mm | | 4 PCS |
| 8 | GLIDES L = 450mm WHT | | 1 SET | 18 | IRON BAR Ø 9.5x293mm SR | | 2 PCS |
| 9 | GLIDES L = 350mm WHT | | 3 SET | 19 | STICKER Ø 20mm | | 7 PCS |
| 10 | SCREW Ø 3x10mm SR | | 50 PCS | | | | |

Z8,Z9,Z11,Z13,Z18 not included in blister packaging.

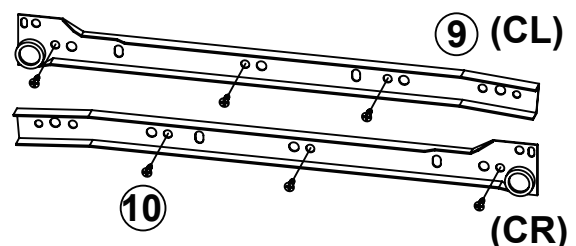
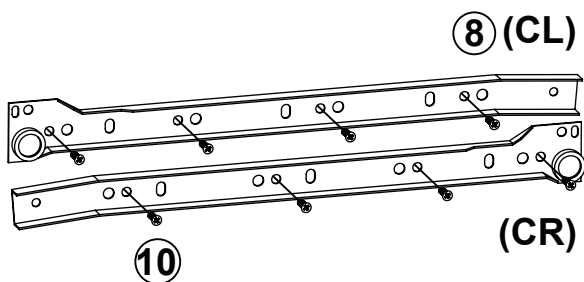

NOTE:

Phillips head screw driver is required in the assembly process; however, manufacturer does not provide this item.

ITEM: 801950

STEP 1

- 2 x 6
- 3 x 8
- 8 x 1 CL
- 9 x 1 CL CR
- 10 x 10
- 15 x 8
- 16
- 17 x 4

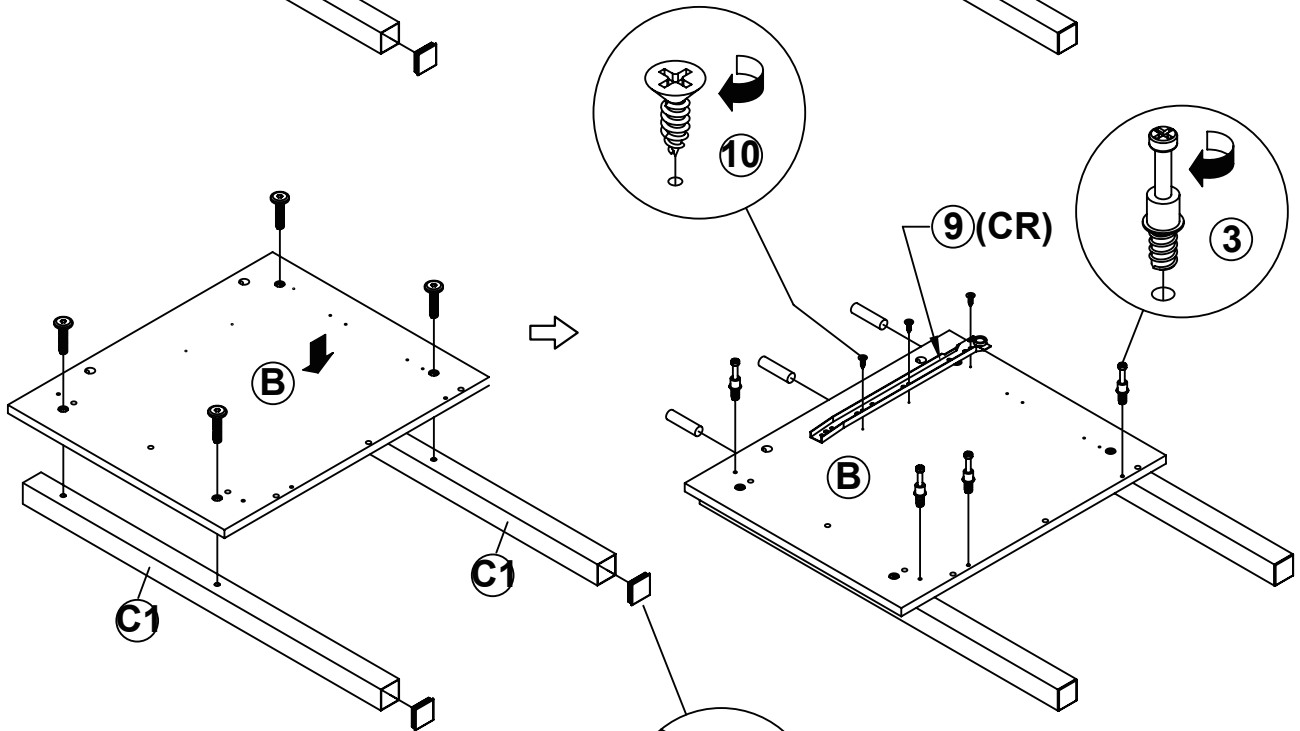
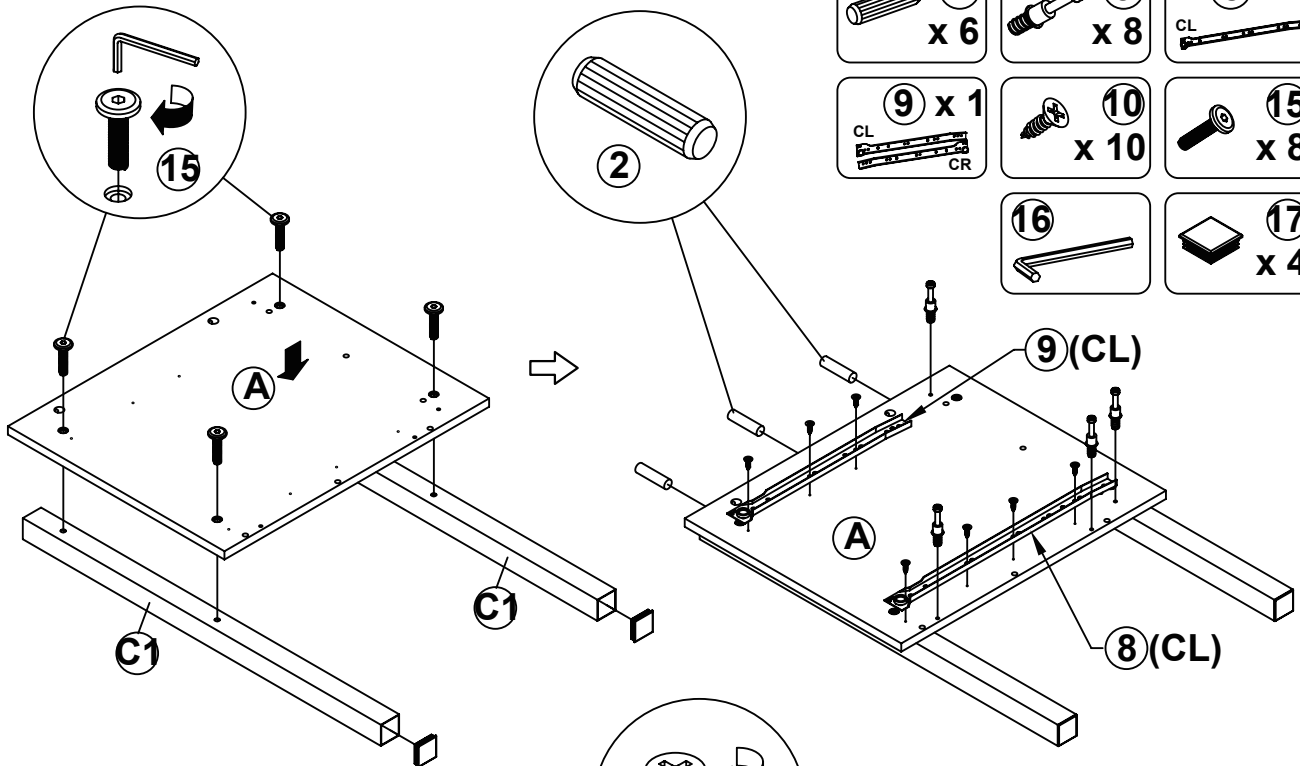

INCORRECT
CORRECT

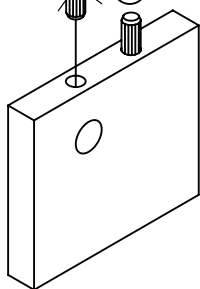

Apply glue on all wooden dowels to ensure integrity of the structure.

ITEM: 801950

STEP 3

- ② x 8
- ③ x 11
- ⑪ x 1
- ⑫ x 2
- ⑬ x 2
- ⑭ x 4

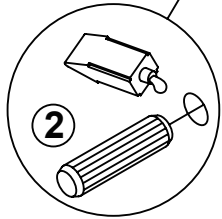
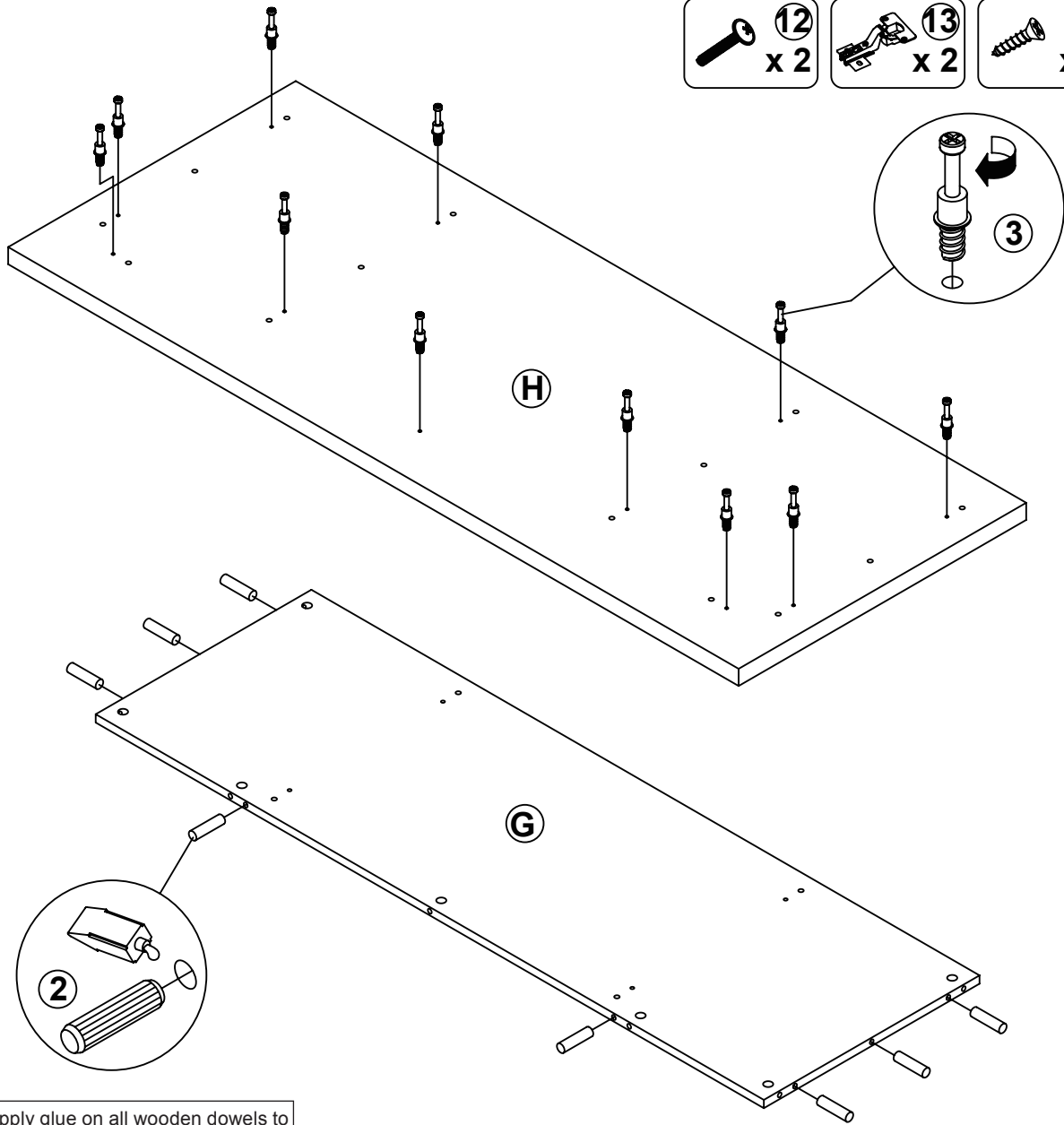

Apply glue on all wooden dowels to ensure integrity of the structure.

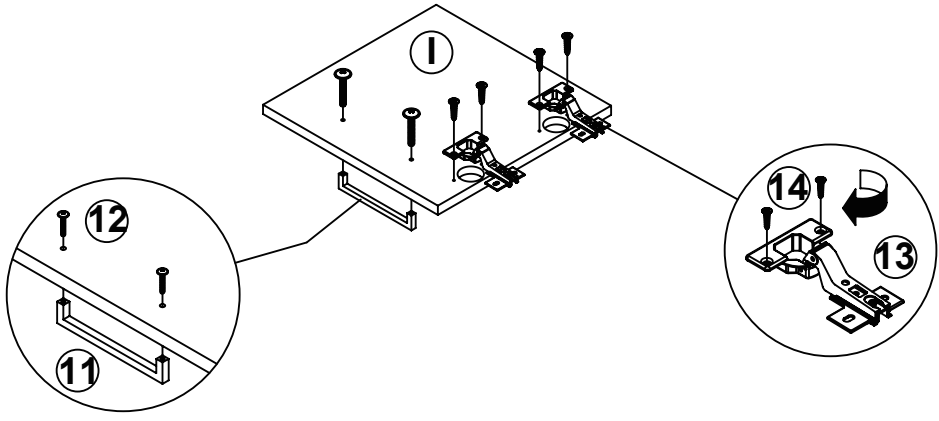

ITEM: 801950

STEP 4

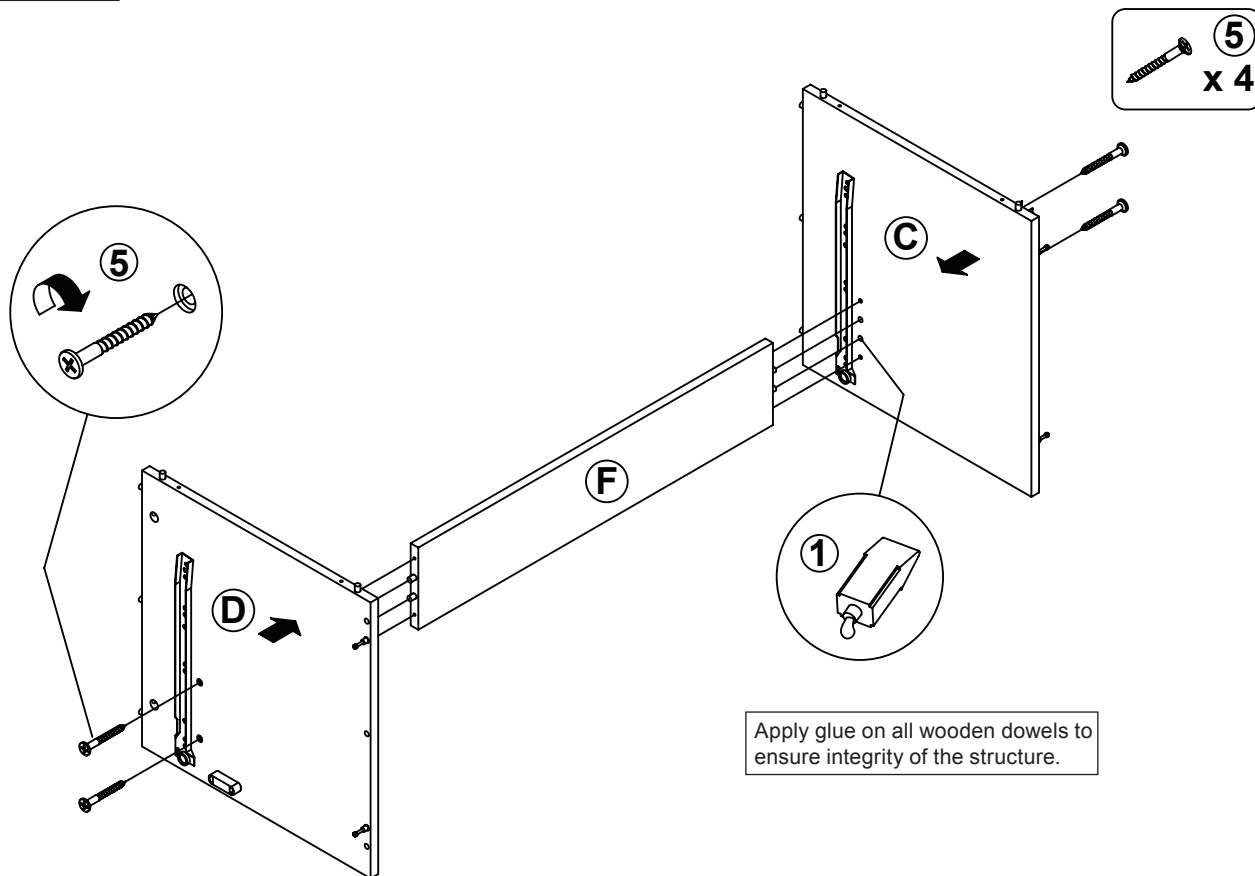

STEP 5

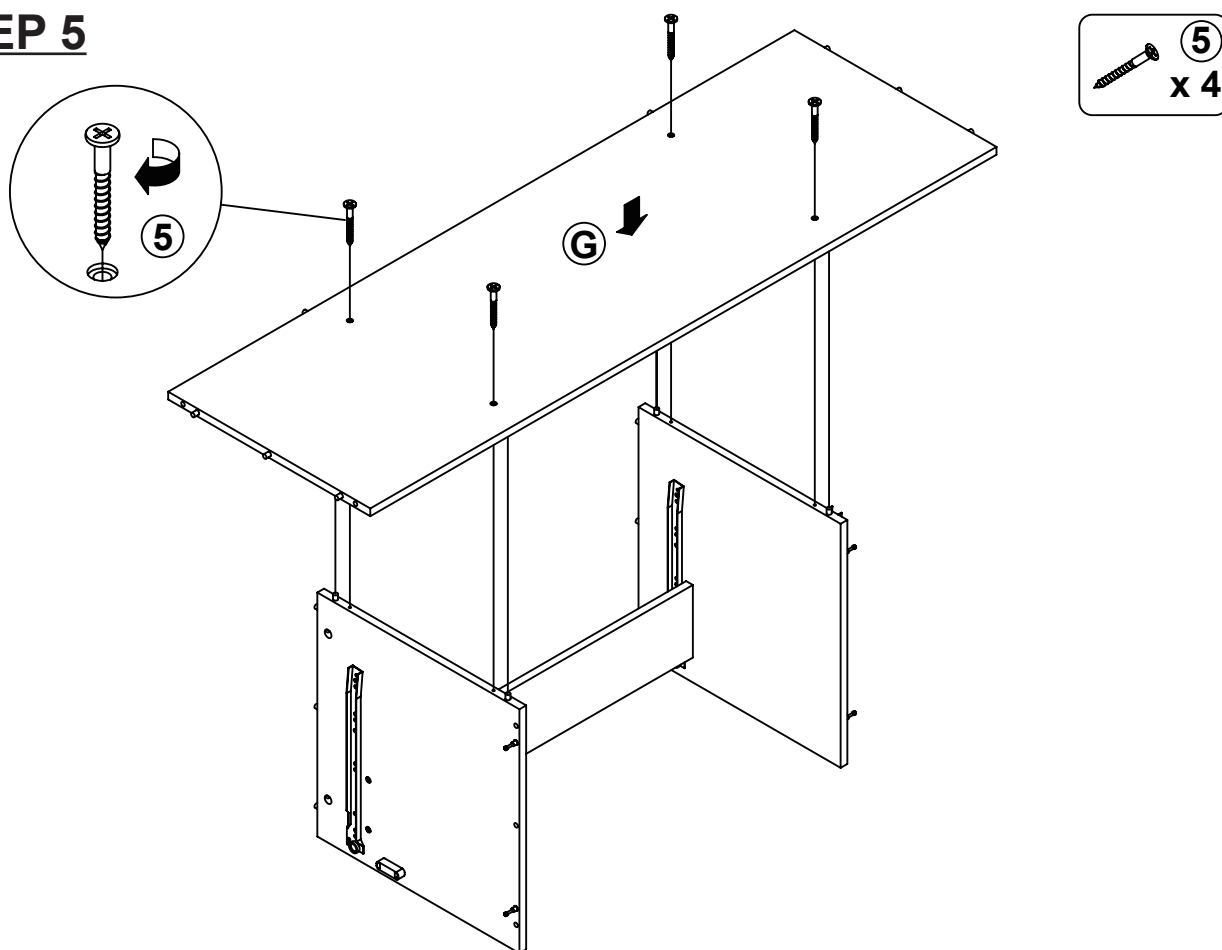

ITEM: 801950

STEP 6

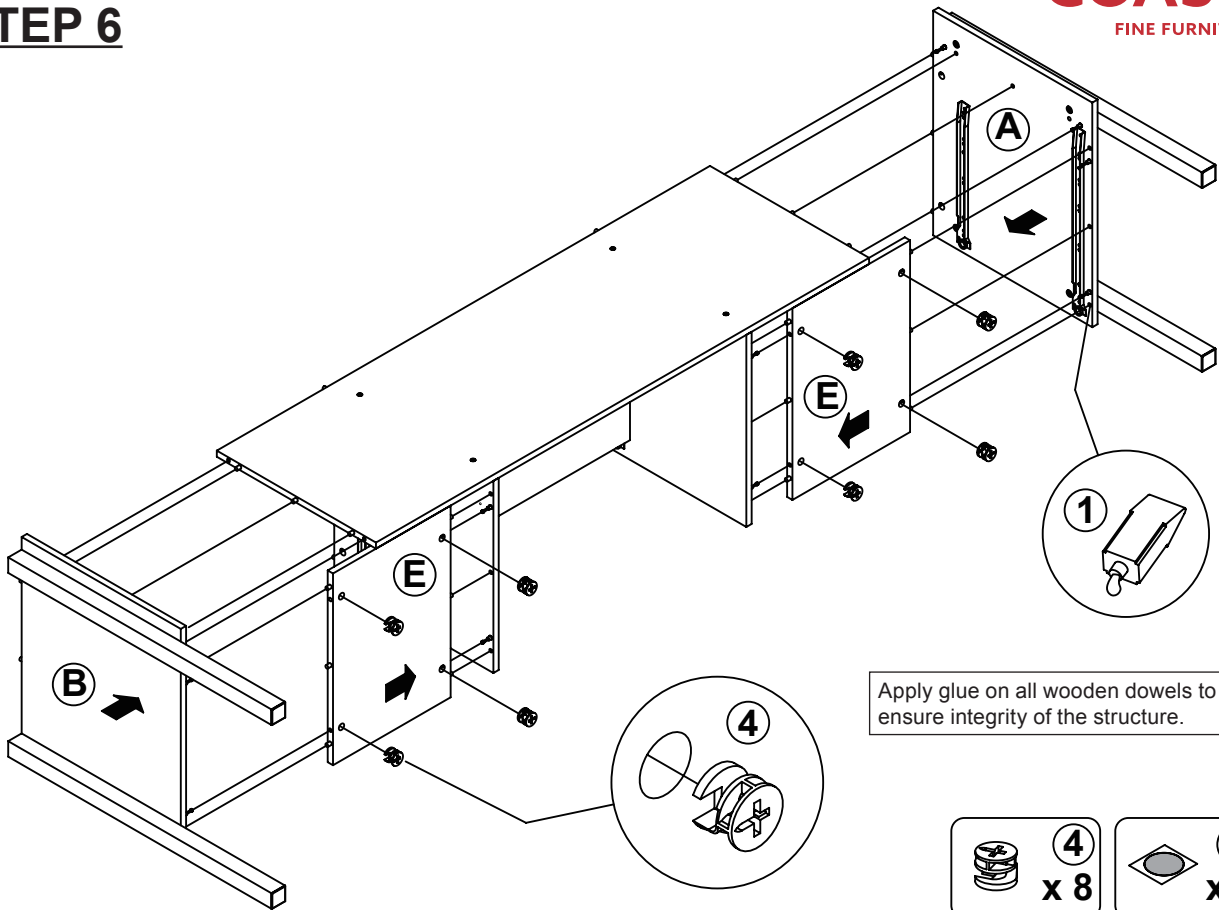

STEP 7

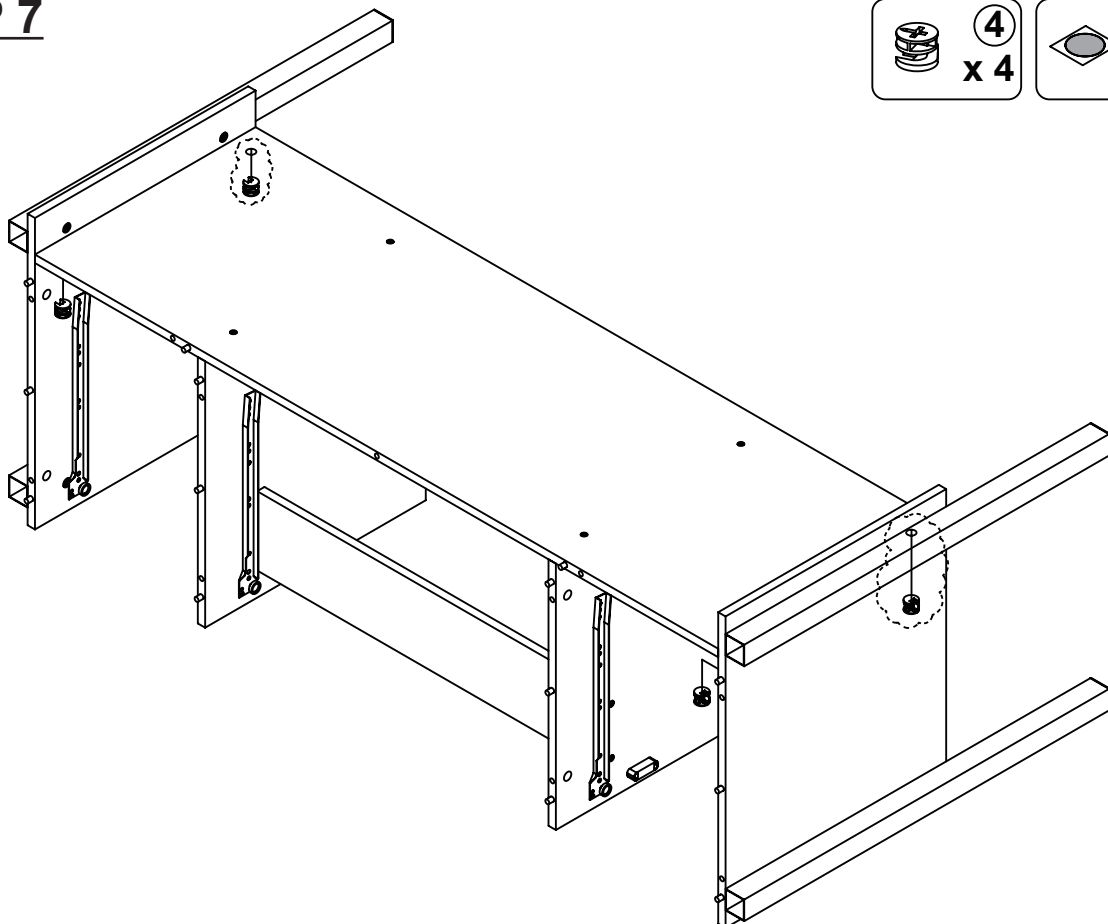

ITEM: 801950

COASTER
FINE FURNITURE

STEP 8

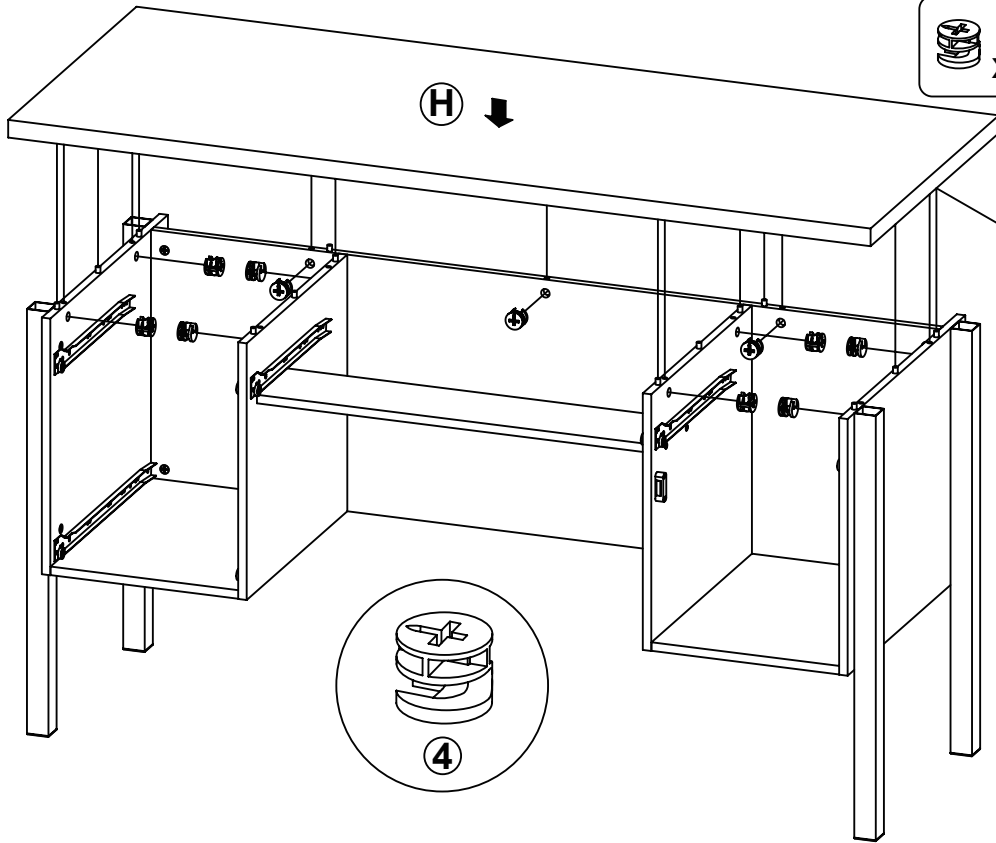

STEP 9

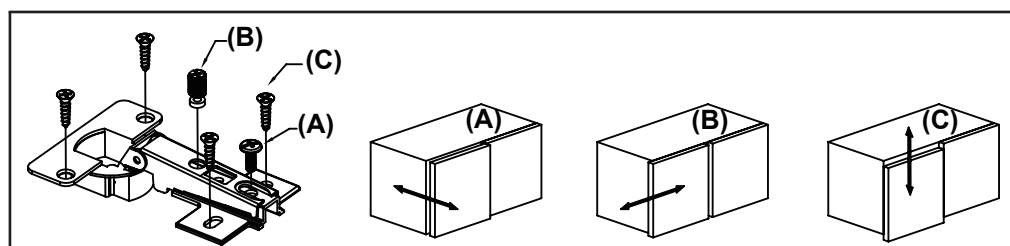
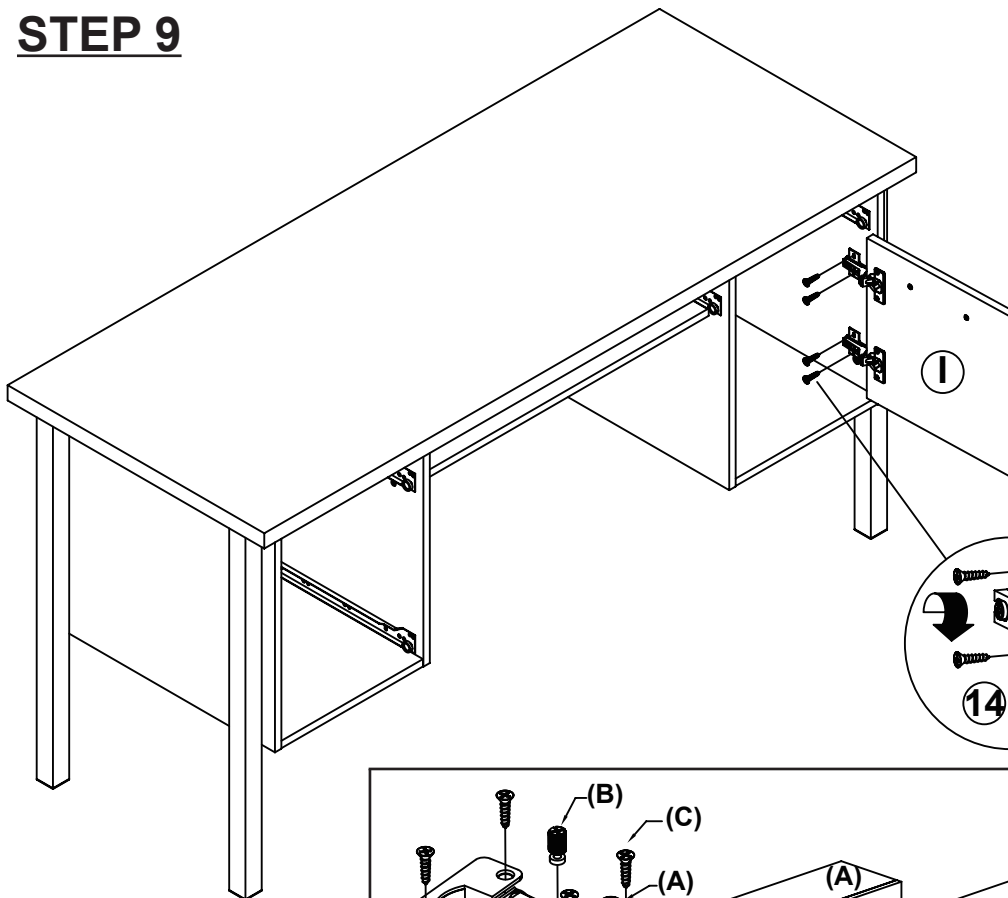

ITEM: 801950

STEP 10-1

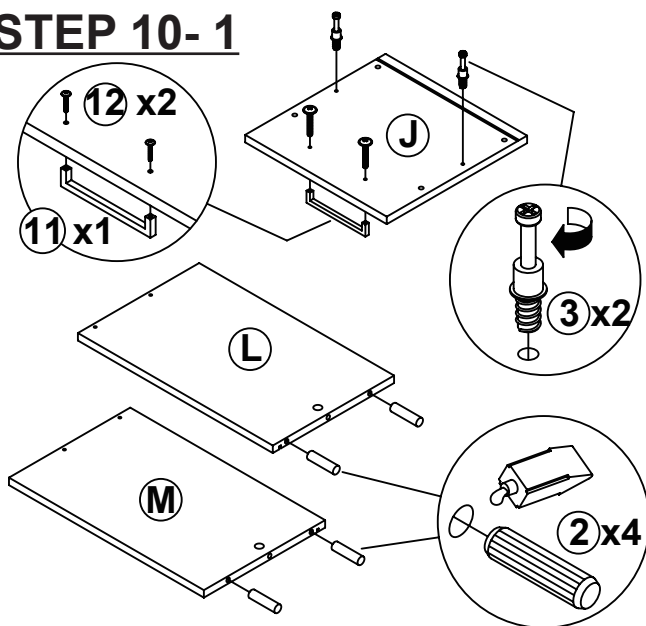

STEP 10-2

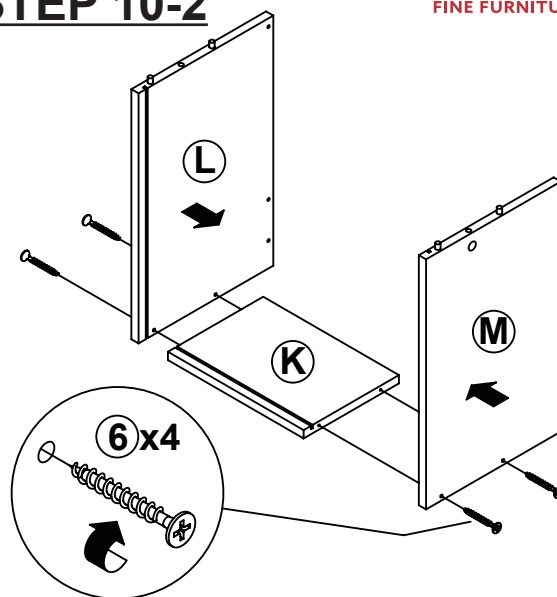

STEP 10-3

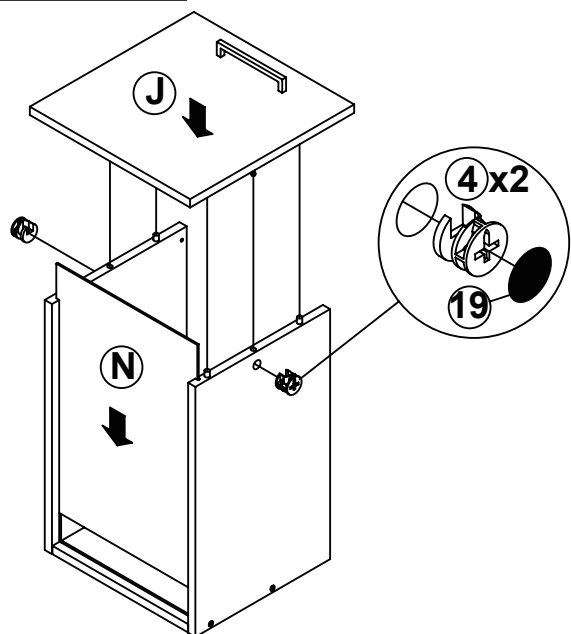

STEP 10-4

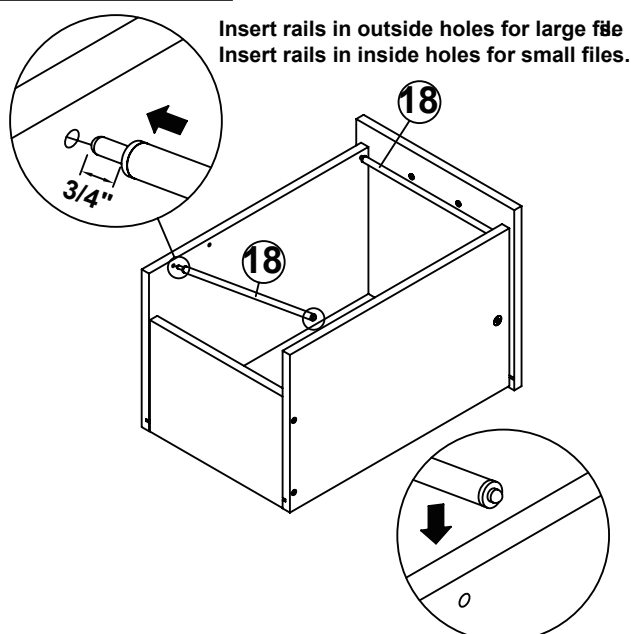

STEP 10-5

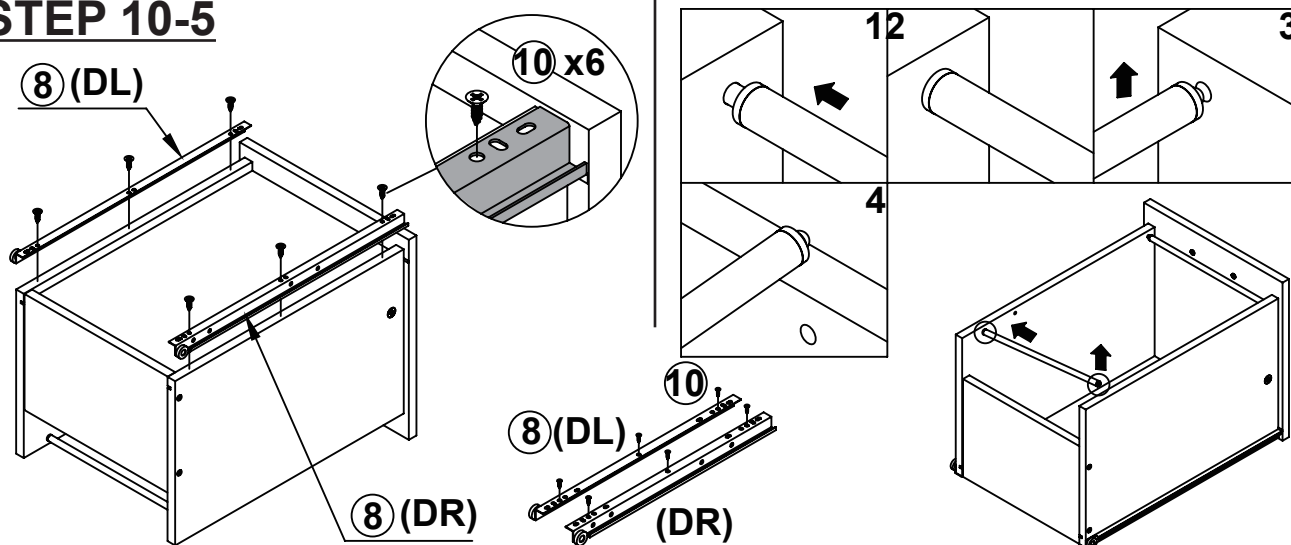

ITEM: 801950

STEP 11-1

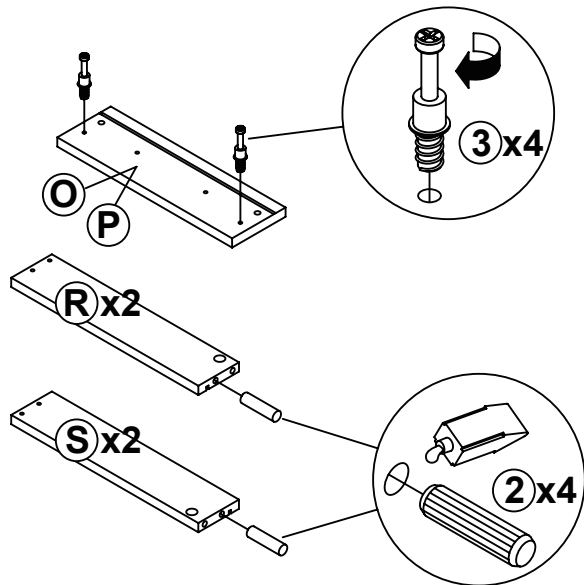

STEP 11-2

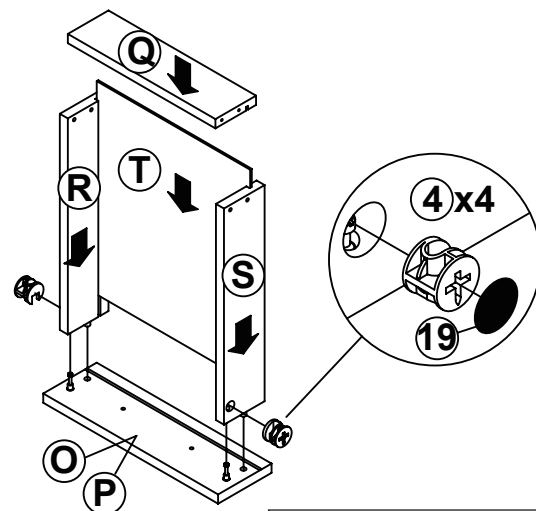

Apply glue on all wooden dowels to ensure integrity of the structure.

STEP 11-3

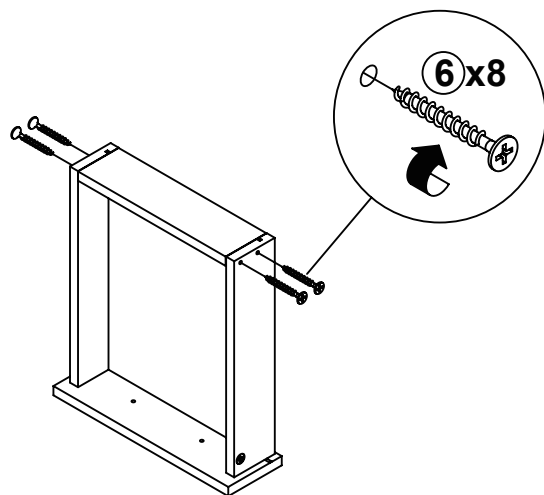

STEP 11-4

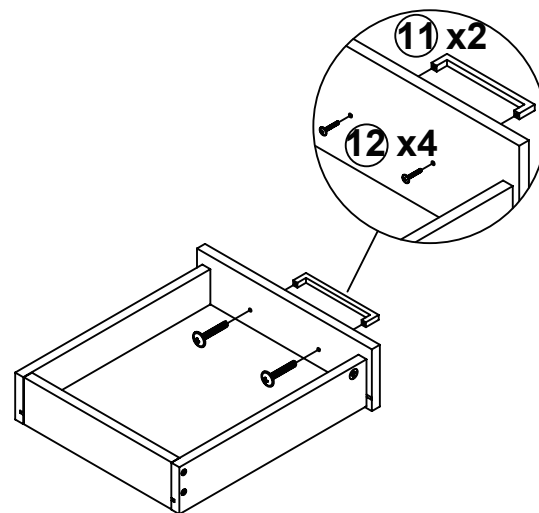

STEP 11-5

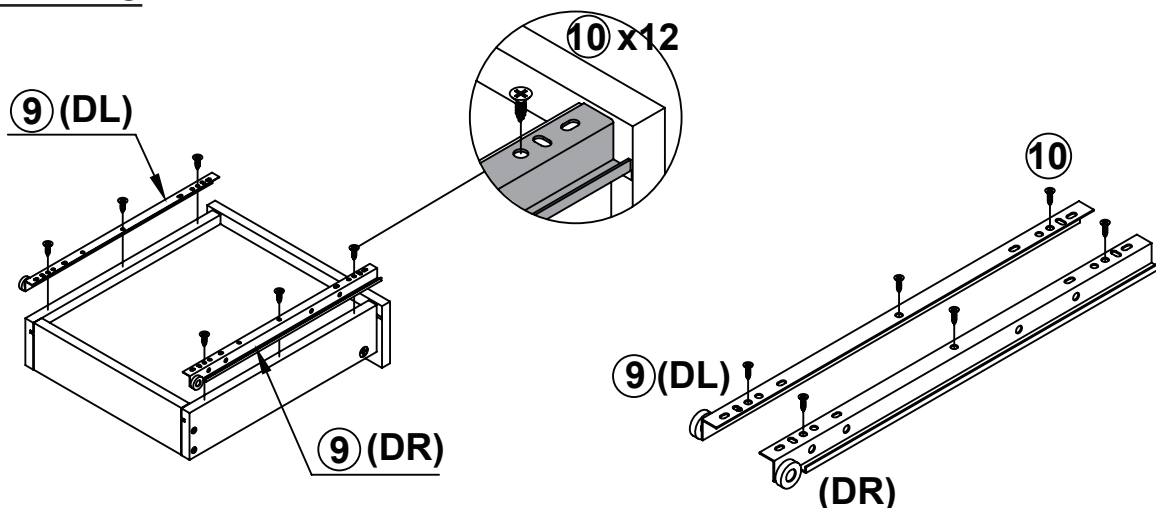

ITEM: 801950

STEP 12-1

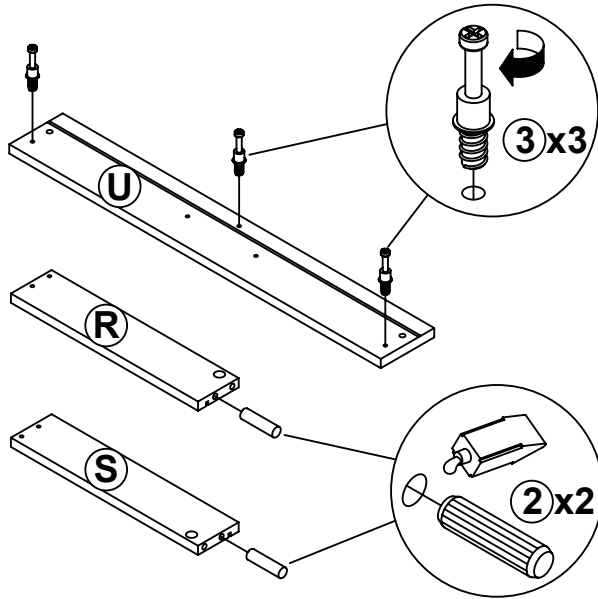

STEP 12-2

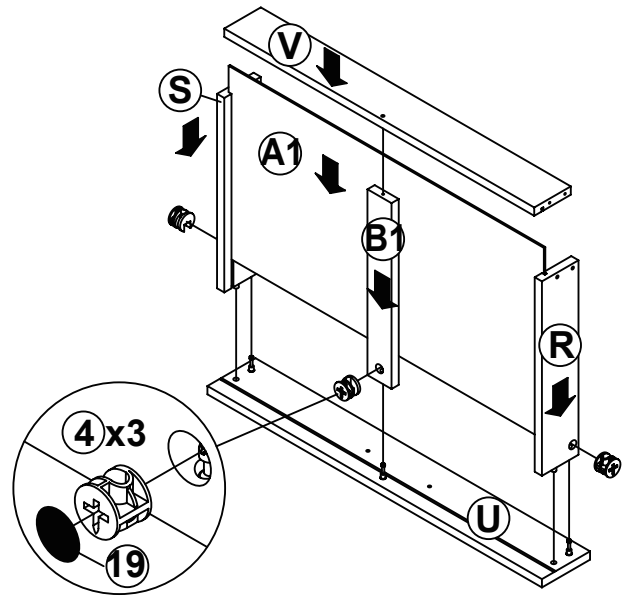

STEP 12-3

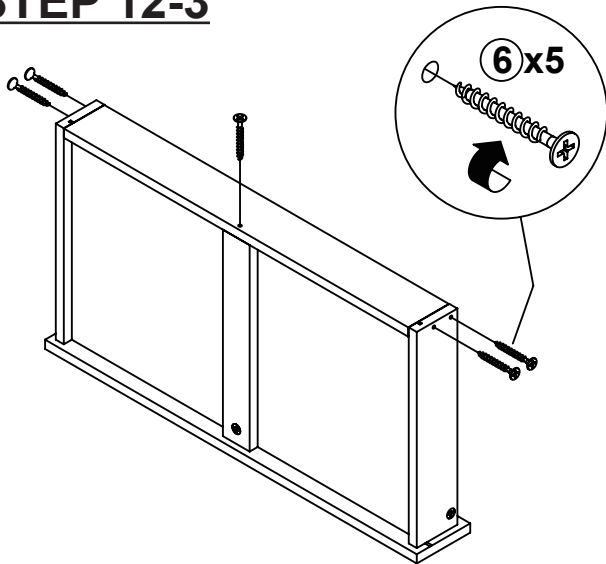

STEP 12-4

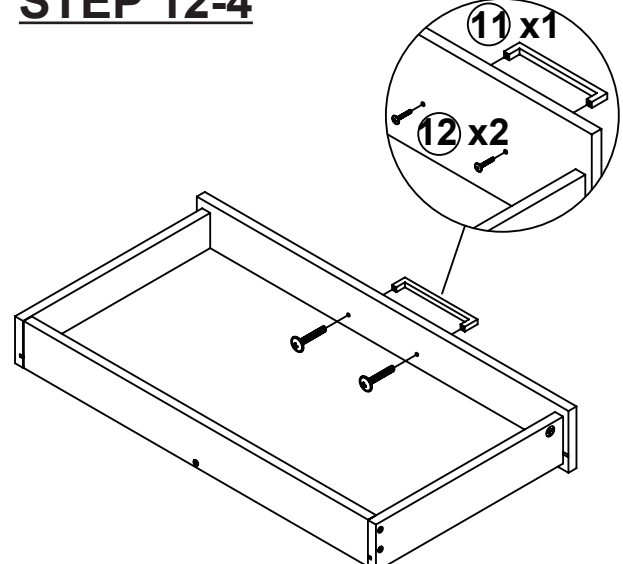

STEP 12-5

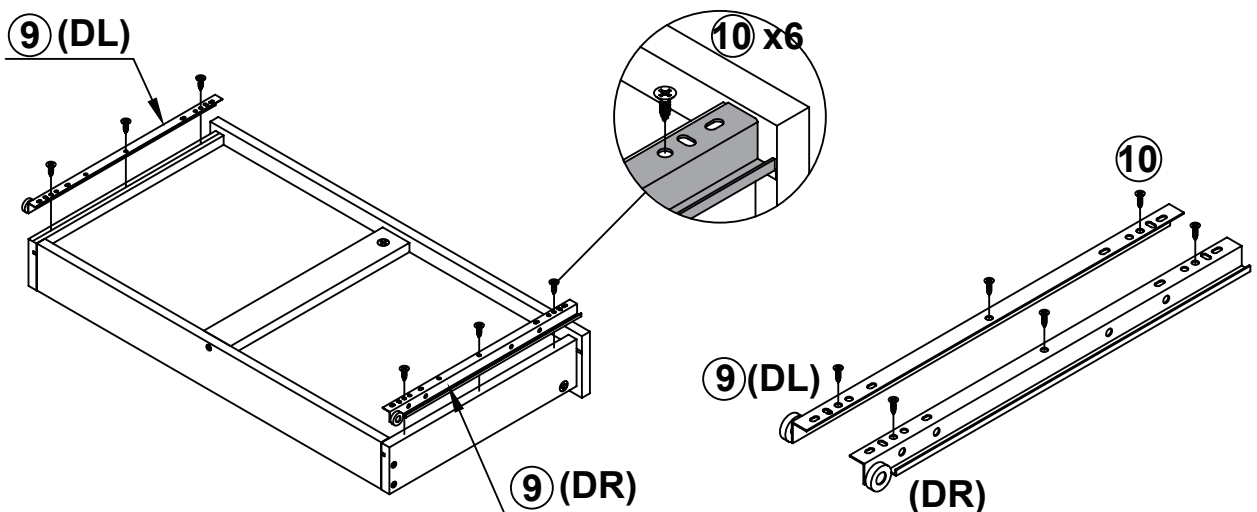

ITEM: 801950

STEP 13

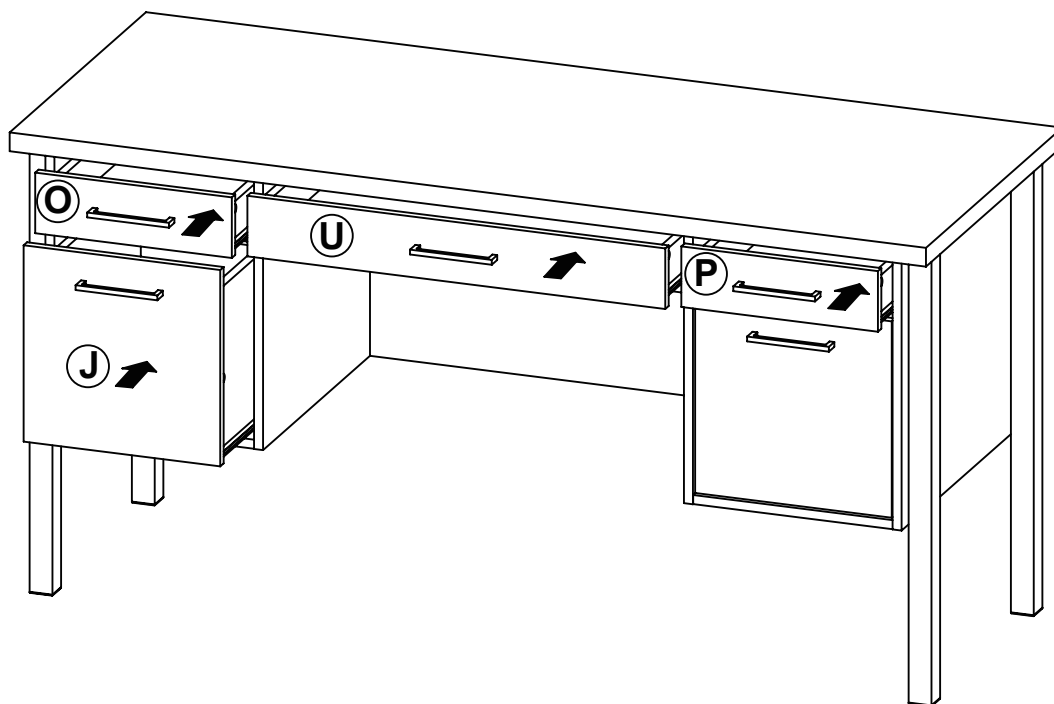

STEP 14

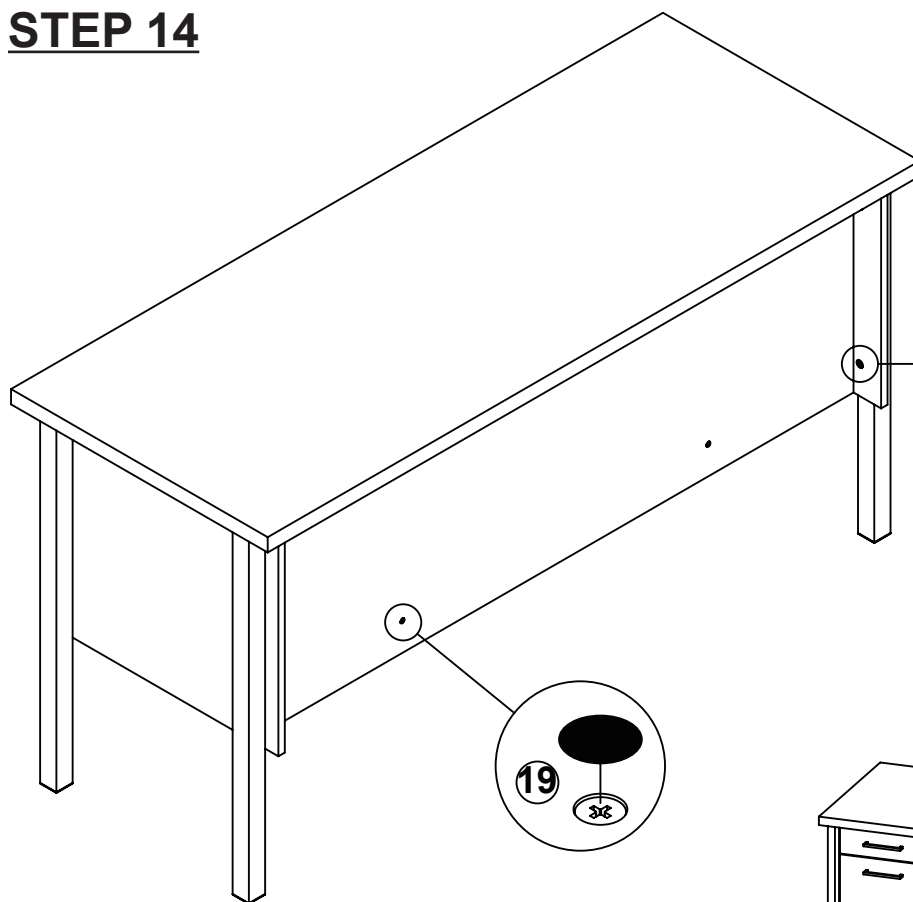
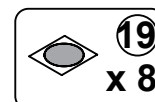

COMPLETE

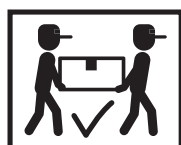
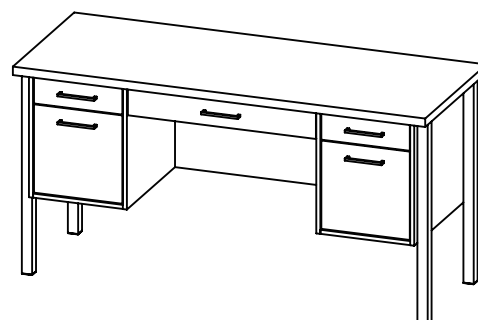

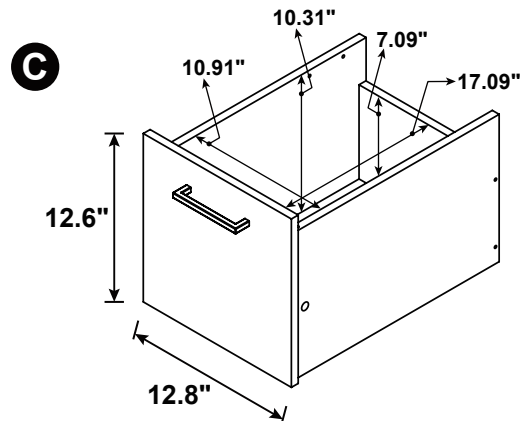
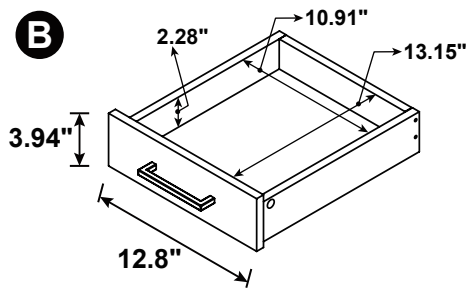
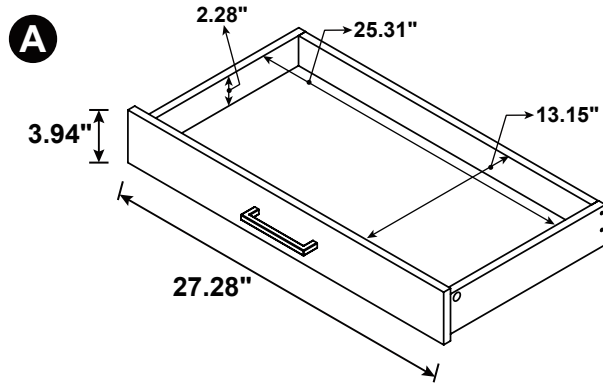
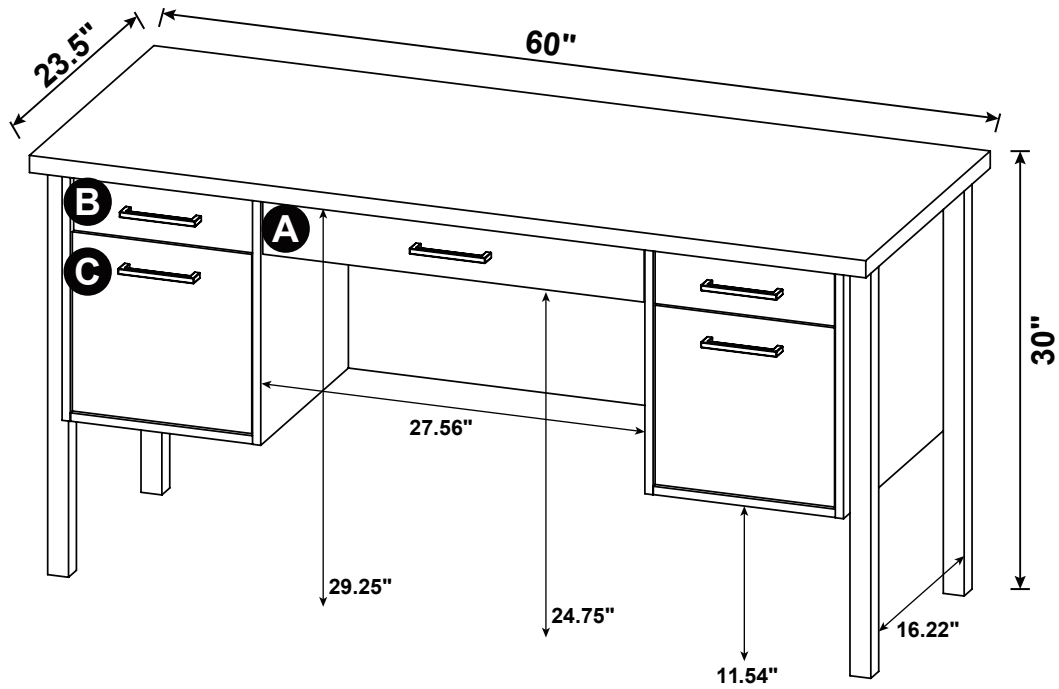

Note : Dimension tolerance $\pm 5\%$