

ASSEMBLY INSTRUCTIONS
COASTER FINE FURNITURE



Fine Furniture for every stage of life

802011
WRITING DESK

ITEM: 802011



ASSEMBLY INSTRUCTIONS

ASSEMBLY TIPS:

1. Remove hardware from box and sort by size.
2. Please check to see that all hardware and parts are present prior to start of assembly.
3. Please follow attached instructions in the same sequence as numbered to assure fast & easy assembly.



WARNING!



1. Don't attempt to repair or modify parts that are broken or defective. Please contact the store immediately.
2. This product is for home use only and not intended for commercial establishments.



ASSEMBLY TIME

40 MINUTES

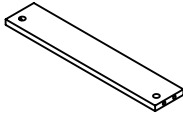
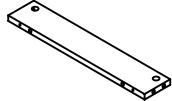
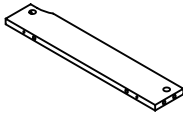
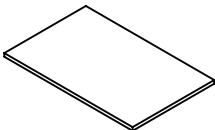
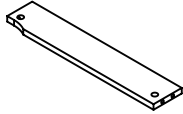
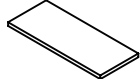
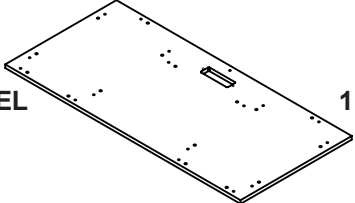
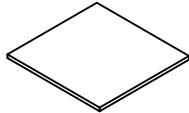
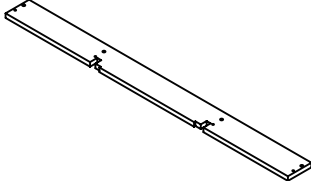
PARTS IDENTIFICATION

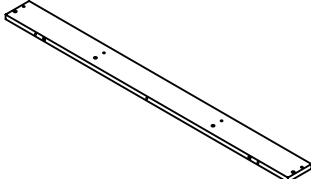
A	SIDE PANEL		2 PCS	G	MIDDLE CROSS BRACE		1 PC
B	LEFT DIVIDER PANEL		1 PC	H	LARGE TOP PANEL		2 PCS
C	RIGHT DIVIDER PANEL		1 PC	I	SMALL TOP PANEL		1 PC
D	BOTTOM PANEL		1 PC	J	TOP PANEL		1 PC
E	FRONT CROSS BRACE		1 PC	K	LEG		4 PCS
F	BACK CROSS BRACE		1 PC				

NOTE:

Phillips head screw driver is required in the assembly process; however, manufacturer does not provide this item.

ITEM:802011

HARDWARE IDENTIFICATION

Z							
NO	DESCRIPTION	FIGURE	Q'TY	NO	DESCRIPTION	FIGURE	Q'TY
1	GLUE 40g		1 PC	9	SCREW FOR RAIL Ø 3.5x14.5mm SR		12 PCS
2	WOODEN DOWEL Ø 8x30mm		26 PCS	10	POWER OUTLET		1 PC
3	CAM BOLT Ø 7x35.5mm SR		10 PCS	11	SCREW FOR POWER OUTLET Ø 3.3x14.5mm BLK		2 PCS
4	CAM LOCK Ø 15x12mm SR		10 PCS	12	HINGE		6 PCS
5	SCREW Ø 4.5x42mm SR		17 PCS	13	SCREW FOR HINGE Ø 3x12mm BLK		24 PCS
6	RAIL L = 350mm SR		1 SET	14	SCREW Ø 5x19mm BLK		16 PCS
7	METAL BRACKET L = 350mm SR		2 PCS	15	TRANSPARENT RUBBER Ø 12mm x 6 HOLE		1 PC
8	BOLT M 4x6mm SR		6 PCS	16	STICKER Ø 20mm		2 PCS

Z6,Z7,Z8,Z9,Z10,Z12 not included in blister packaging.

INCORRECT
CORRECT

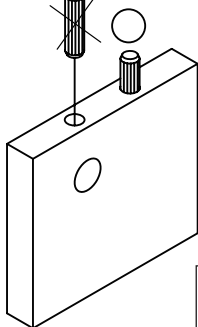

Apply glue on all wooden dowels to ensure integrity of the structure.

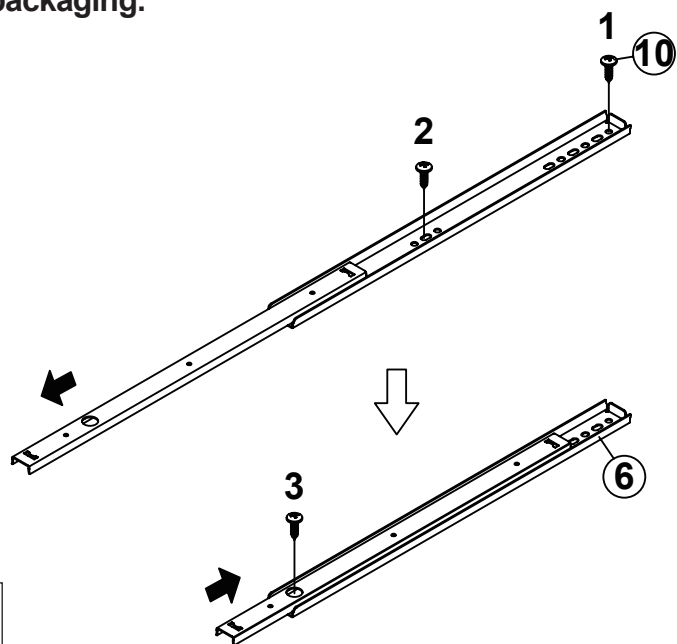

NOTE:

Phillips head screw driver is required in the assembly process; however, manufacturer does not provide this item.

ITEM: 802011

STEP 1

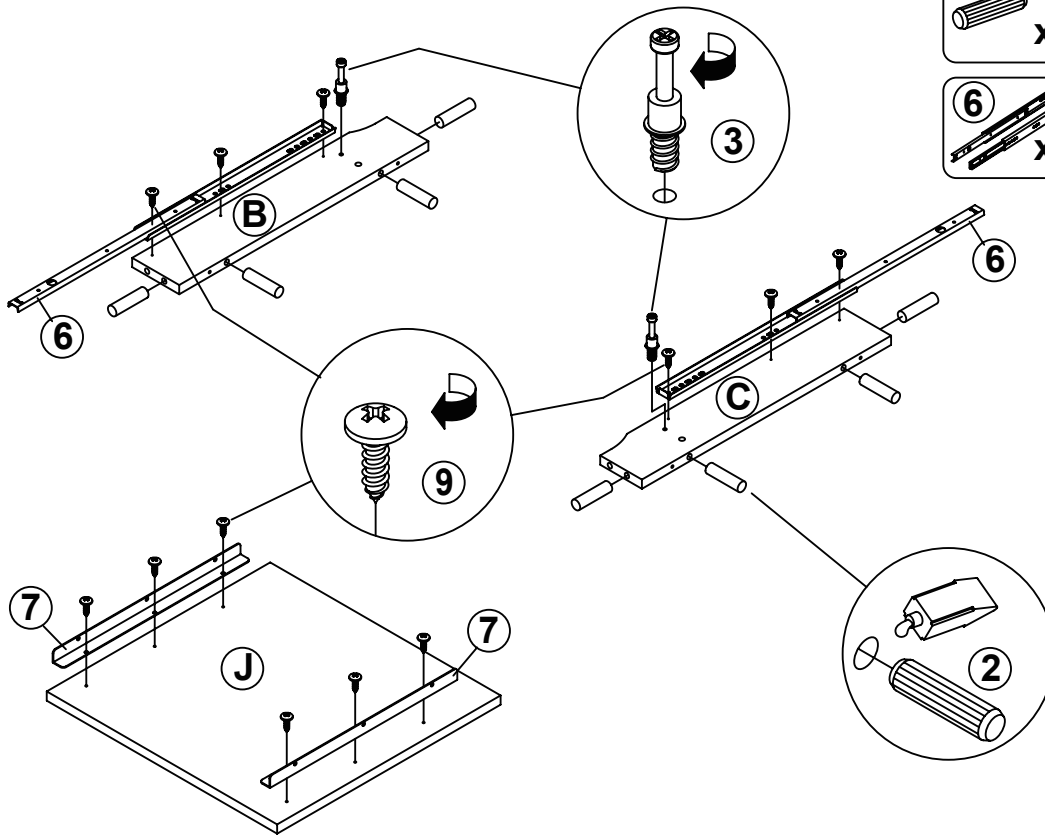

STEP 2

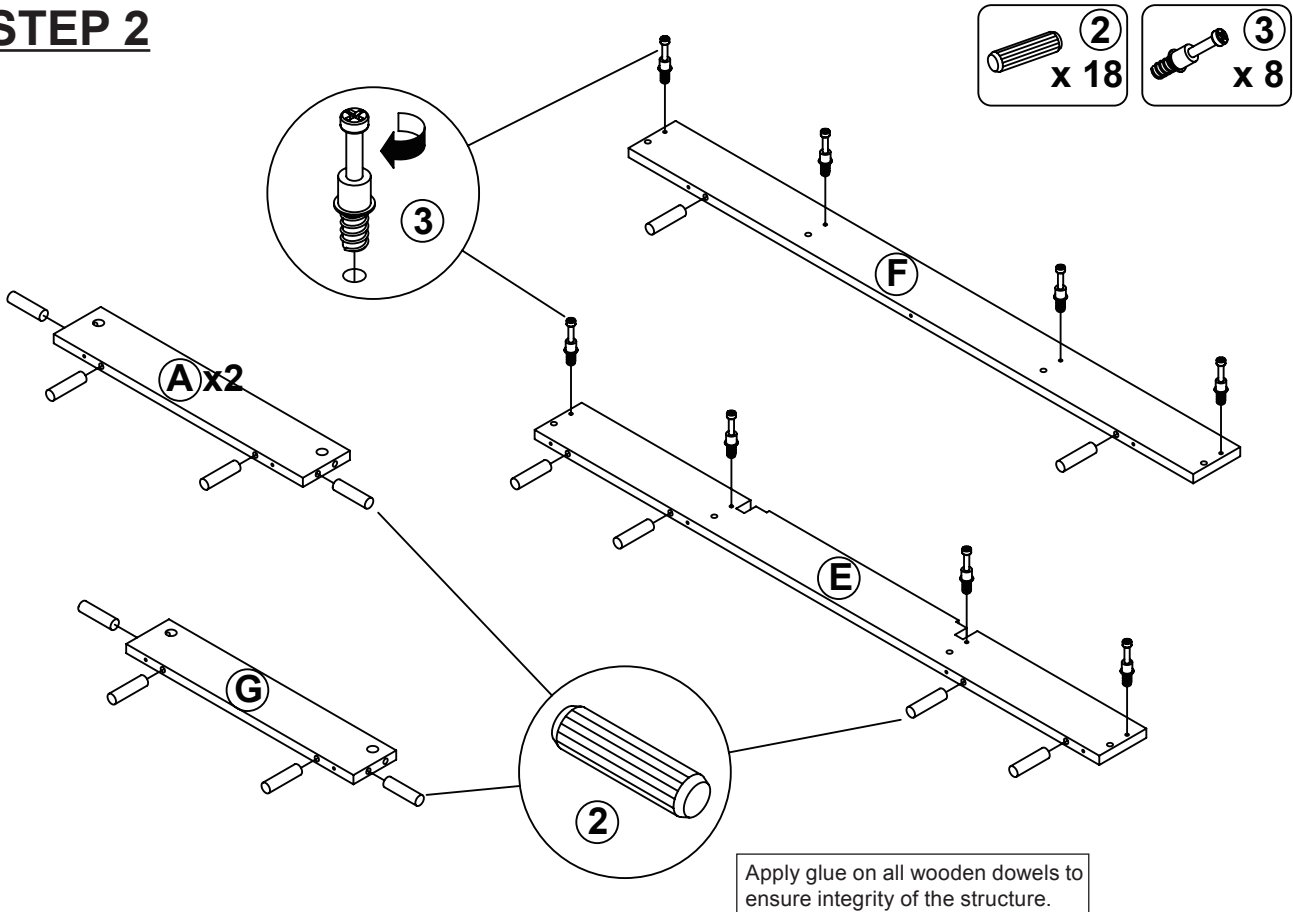

Apply glue on all wooden dowels to ensure integrity of the structure.

ITEM: 802011

COASTER
FINE FURNITURE

STEP 3

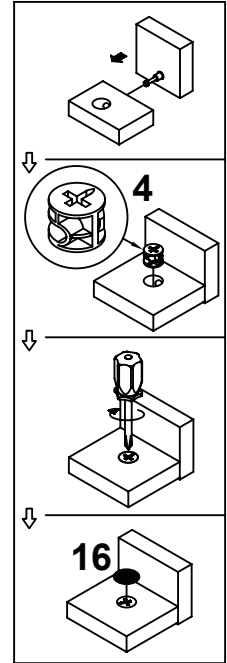
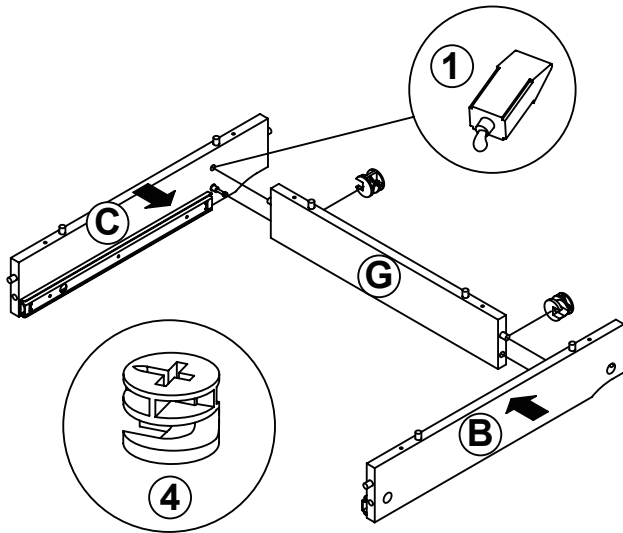
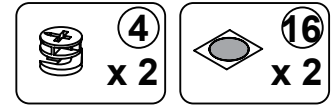

STEP 4

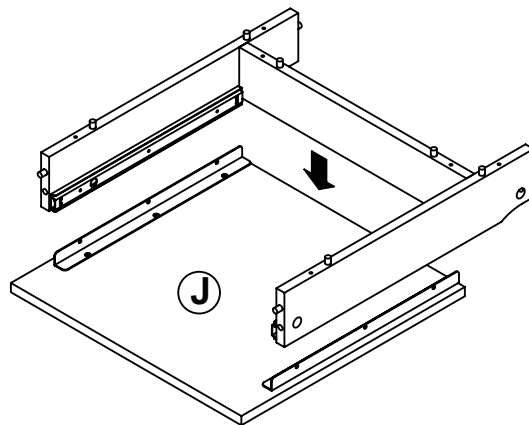

STEP 5

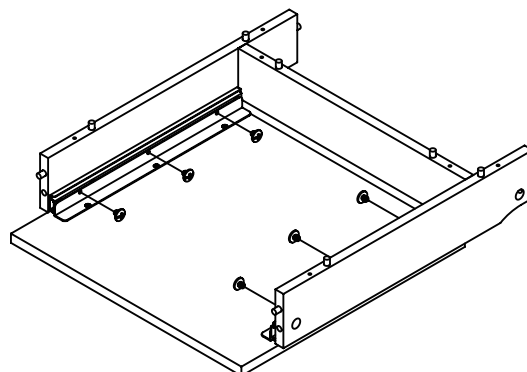
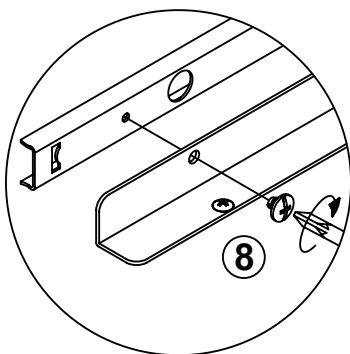

ITEM: 802011

COASTER
FINE FURNITURE

STEP 6

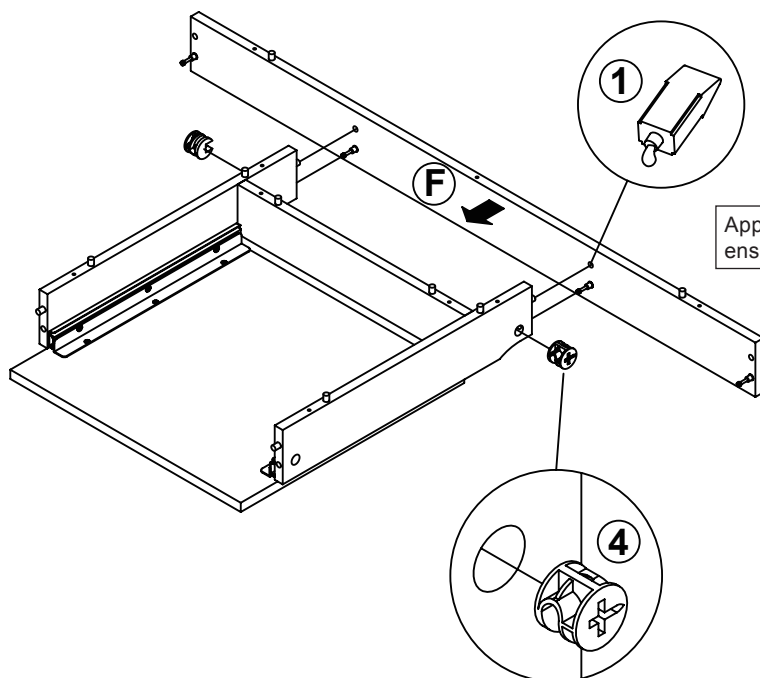
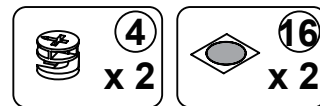

Apply glue on all wooden dowels to ensure integrity of the structure.

STEP 7

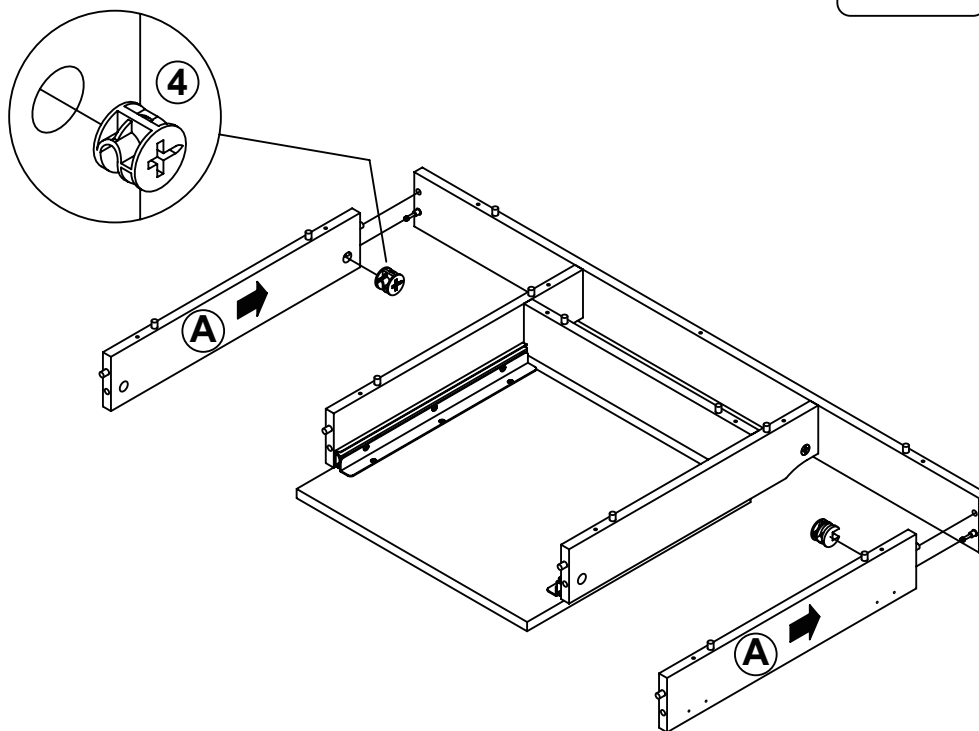

ITEM: 802011

COASTER
FINE FURNITURE

STEP 8

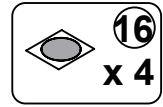
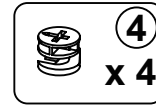
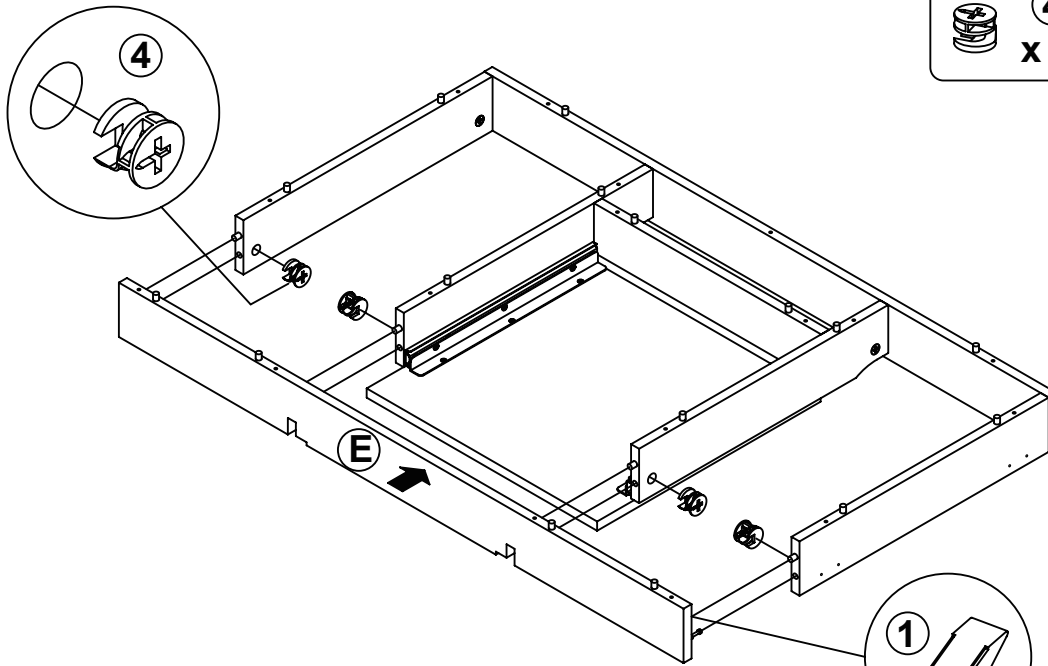

Apply glue on all wooden dowels to ensure integrity of the structure.

STEP 9

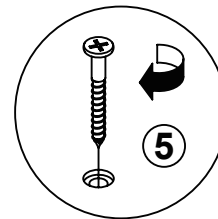
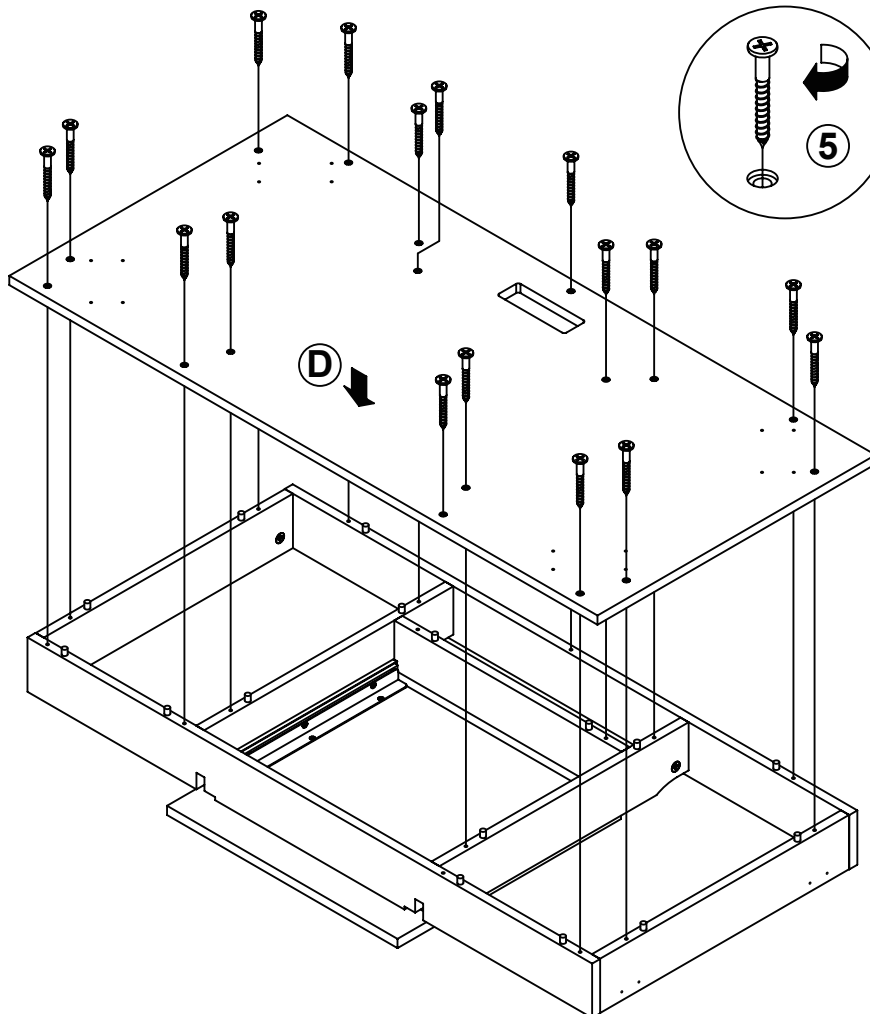

ITEM: 802011

COASTER
FINE FURNITURE

STEP 10

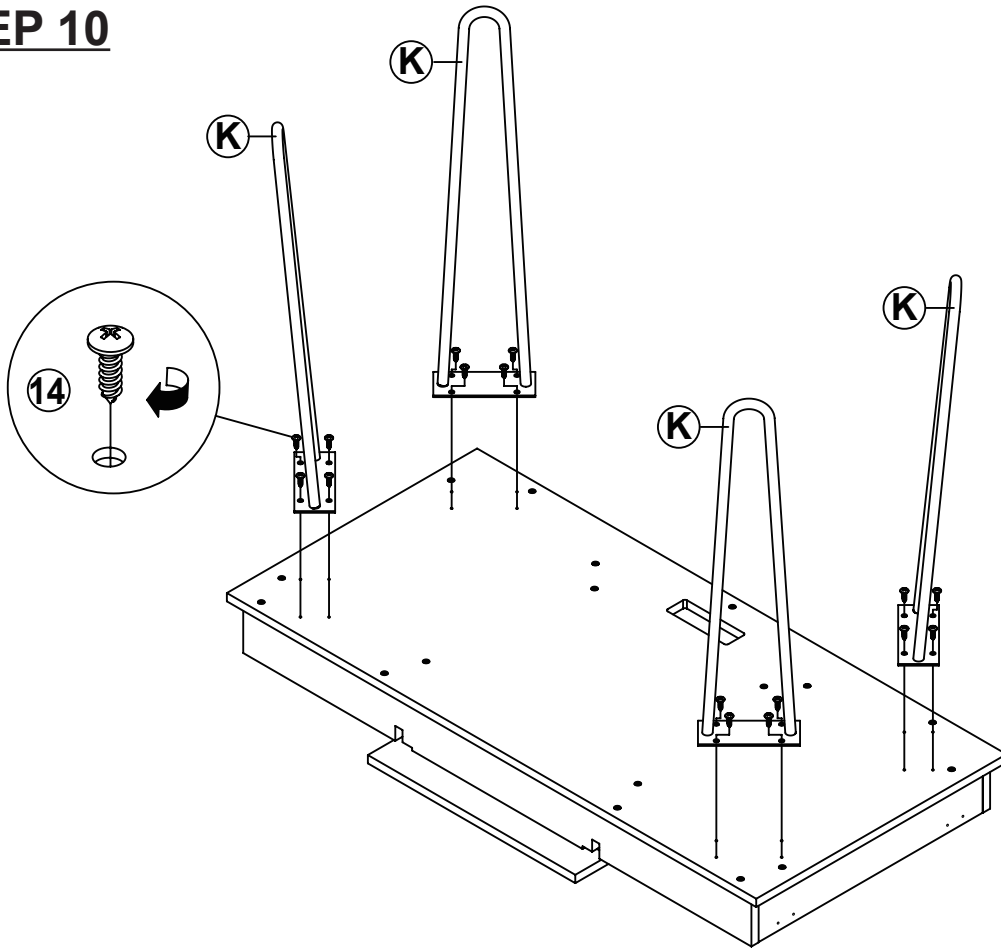
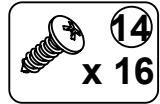

STEP 11

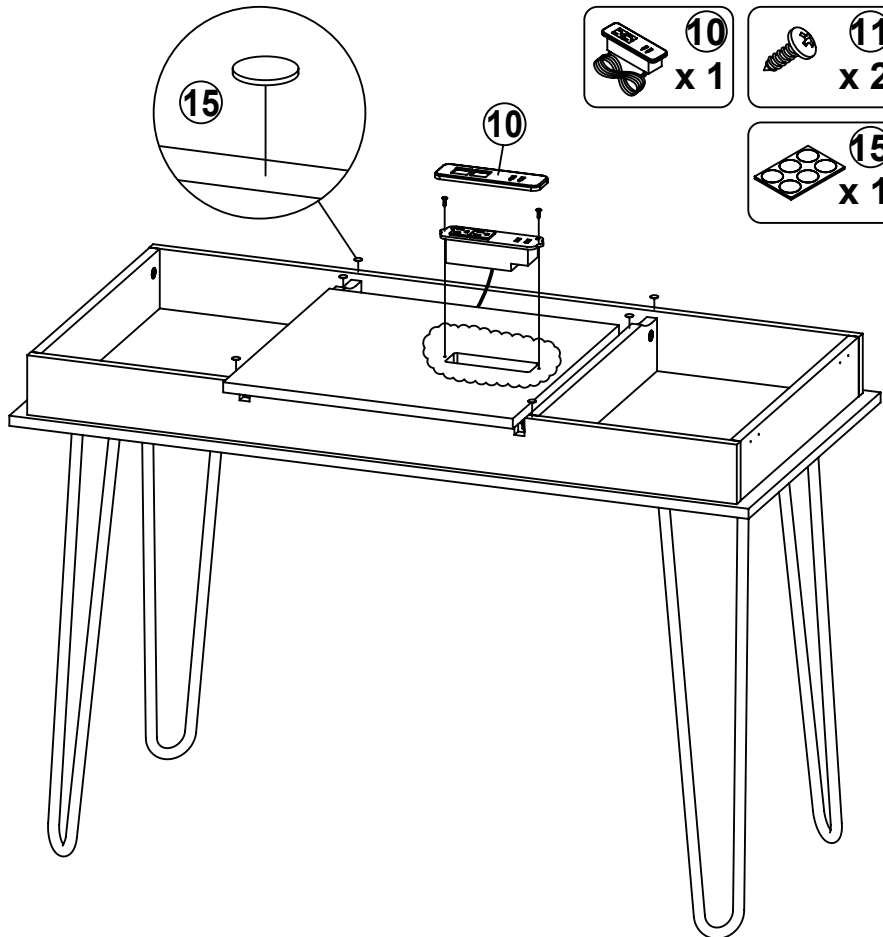
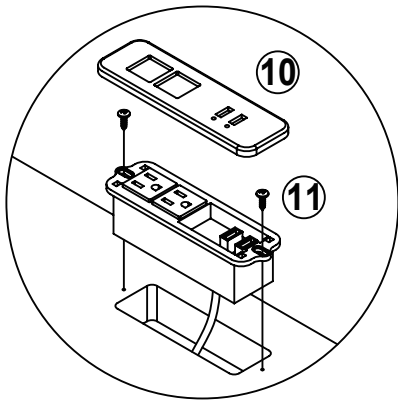
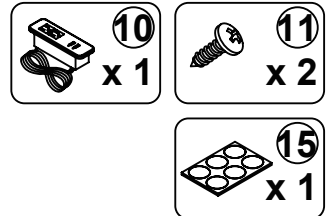

ITEM: 802011

COASTER
FINE FURNITURE

STEP 12

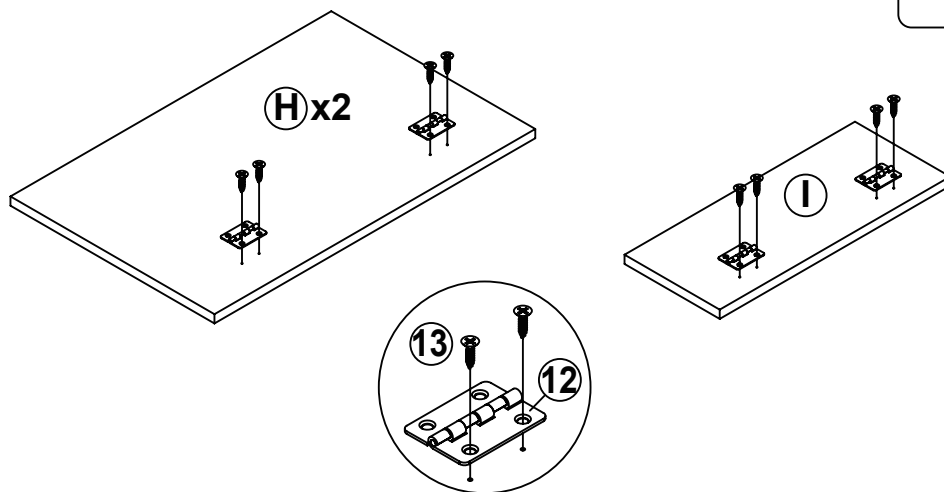

STEP 13

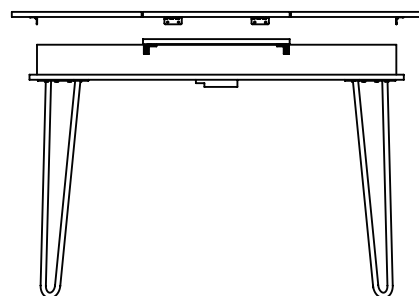
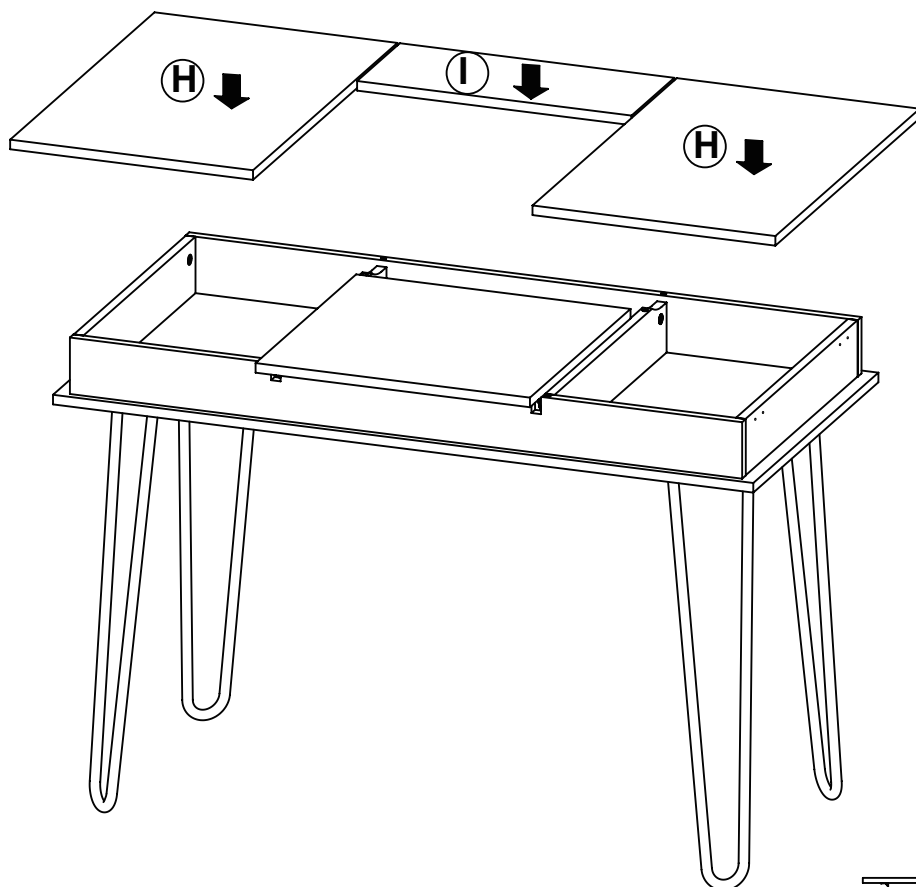

ITEM: **802011**

COASTER
FINE FURNITURE

STEP 14

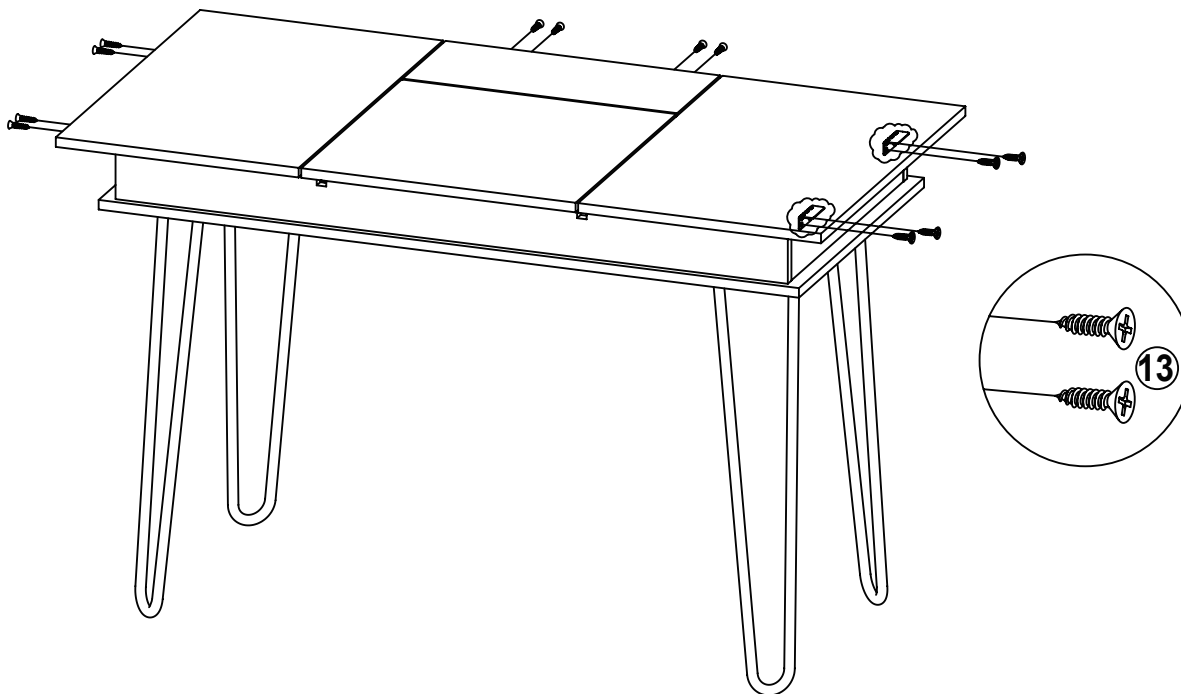
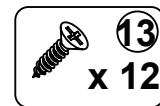

STEP 15
COMPLETE

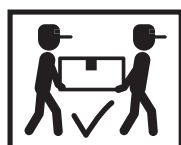
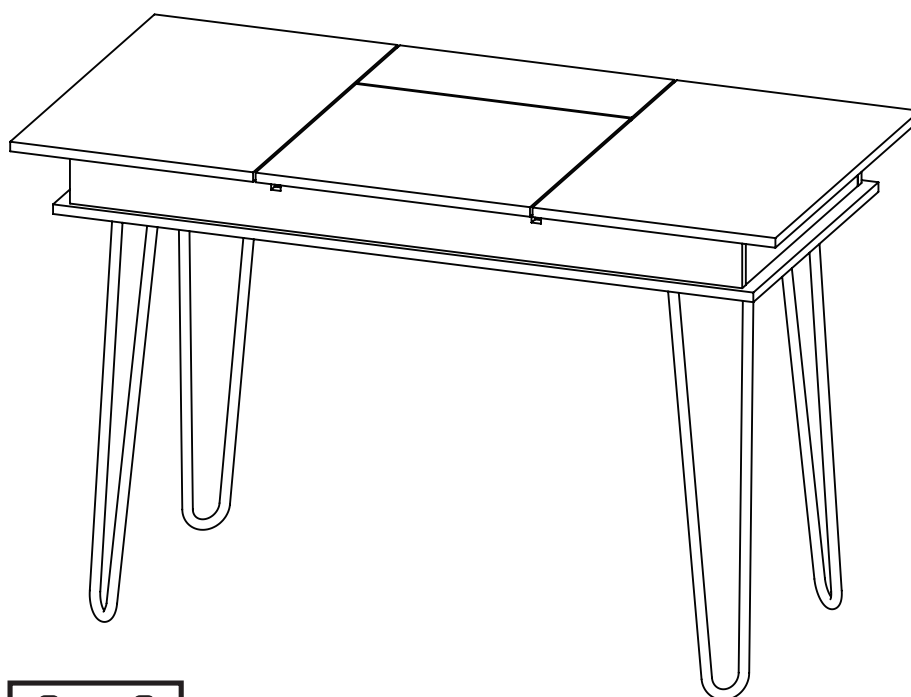

ITEM:802011

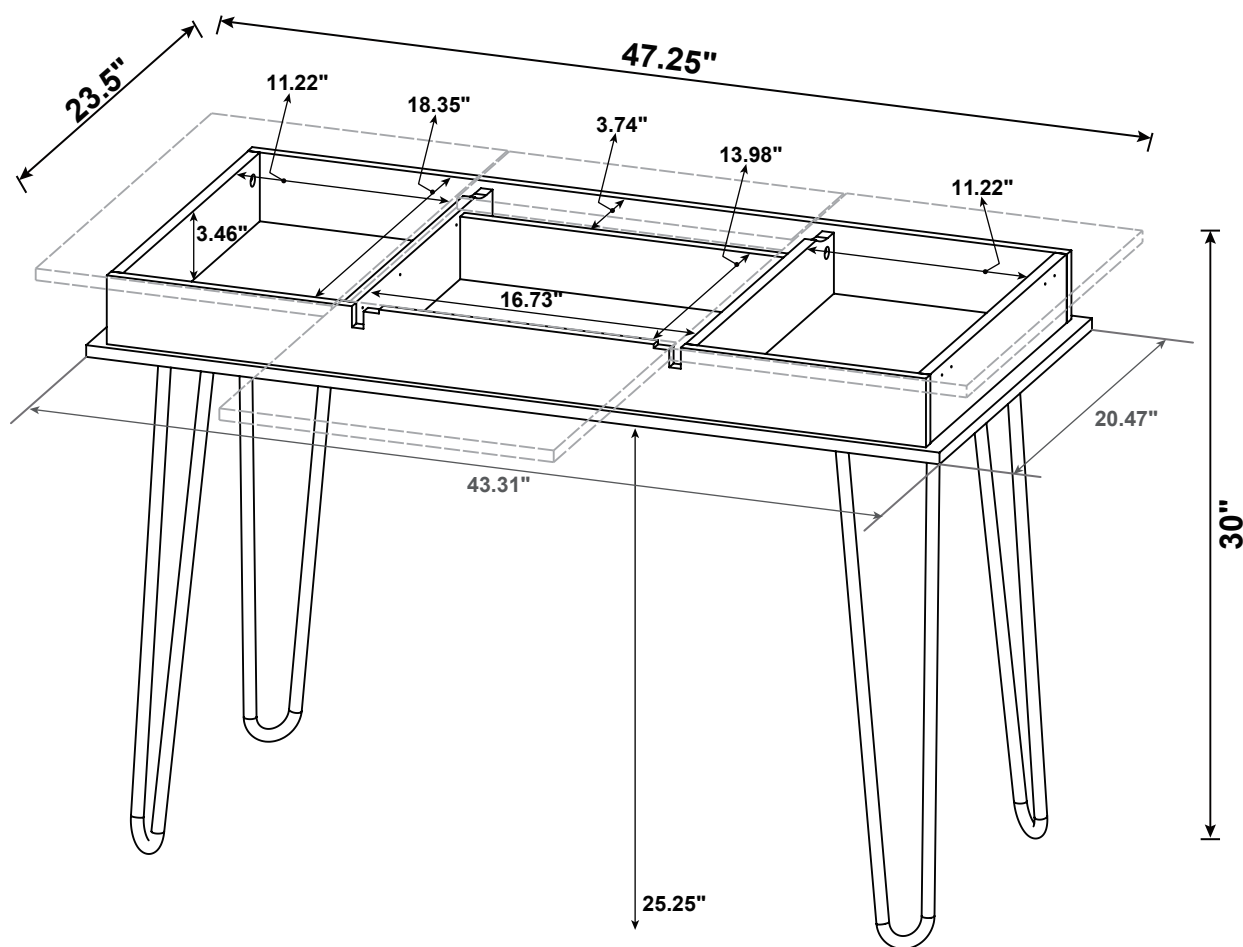

Note : Dimension tolerance $\pm 5\%$