

ASSEMBLY INSTRUCTIONS
COASTER FINE FURNITURE

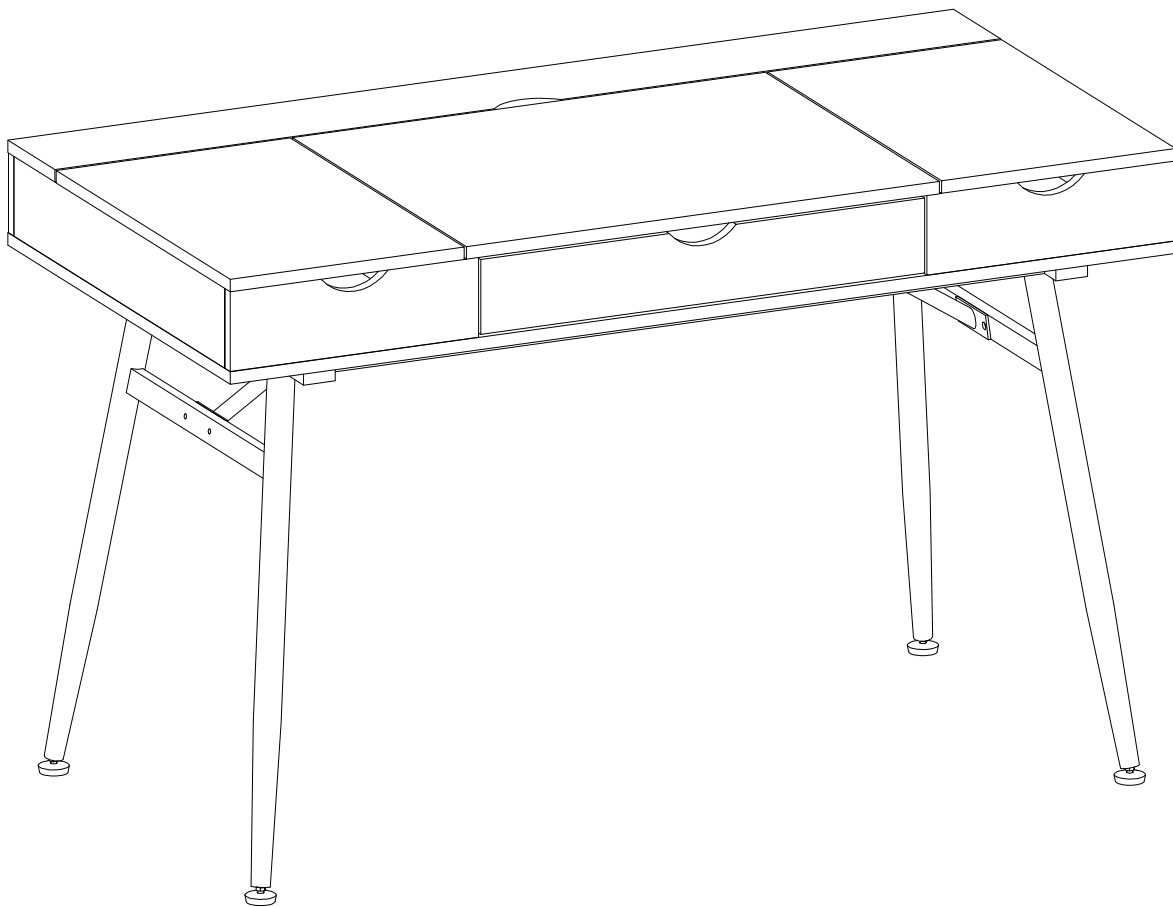

Fine Furniture for every stage of life

801935
Writing Desk

ITEM: **801935**



ASSEMBLY INSTRUCTIONS

ASSEMBLY TIPS:

1. Remove hardware from box and sort by size.
2. Please check to see that all hardware and parts are present prior to start of assembly.
3. Please follow attached instructions in the same sequence as numbered to assure fast & easy assembly.



WARNING!



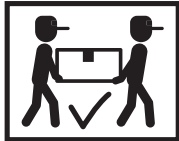







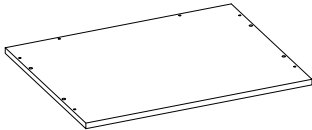
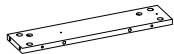
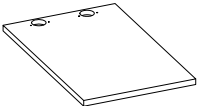
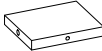
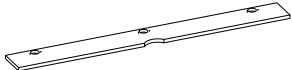

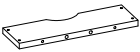

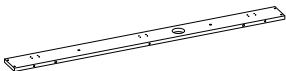

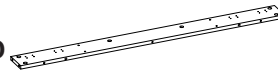
1. Don't attempt to repair or modify parts that are broken or defective. Please contact the store immediately.
2. This product is for home use only and not intended for commercial establishments.

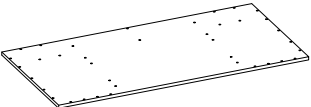

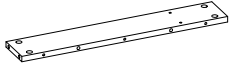
ASSEMBLY TIME

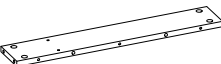
30 MINUTES

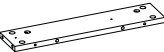







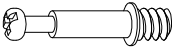
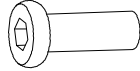
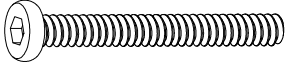
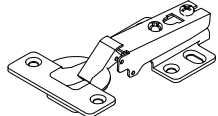
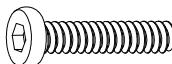

PARTS IDENTIFICATION

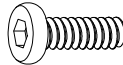
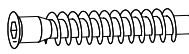
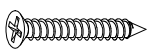
A	TOP		1PC	J2N	FRONT LEFT MIDDLE PANEL		1PC
B	SIDE TOP LID		2PCS	KN	BACK MIDDLE PANEL		2PCS
C	LARGE TOP LID		1PC	L	DRAWER FRONT PANEL		1PC
DN	SIDE FRONT PANEL		2PCS	MN	DRAWER LEFT SIDE PANEL		1PC
EN	LARGE BACK BOARD		1PC	NN	DRAWER RIGHT SIDE PANEL		1PC
FN	LARGE FRONT BOARD		1PC	ON	DRAWER BACK PANEL		1PC
GN	BOTTOM PANEL		1PC	P	DRAWER BOTTOM PANEL		1PC
HN	LEFT SIDE PANEL		1PC	Q	METAL FRAME		2PCS
IN	RIGHT SIDE PANEL		1PC	R	SUPPORT BAR		2PCS
J1N	FRONT RIGHT MIDDLE PANEL		1PC	S	CROSSBAR		2PCS

NOTE:

Phillips head screw driver is required in the assembly process; however, manufacturer does not provide this item.

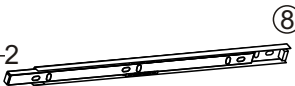
ZN-HARDWARE IDENTIFICATION

①	CAM BOLT		30PCS	⑨	FEMALE BOLT (M6*15)		4PCS
②	BOLT (M6*60mm)		4PCS	⑩	HINGE		7PCS
③	BOLT (M6*30mm)		8PCS	⑪	LEVELER		4PCS
④	BOLT (M6*12mm)		12PCS	⑫	SCREW (M7*50mm)		22PCS
⑤	SCREW (M4*30mm)		6PCS	⑬	COM LOCK		30PCS
⑥	SCREW (M3.5*12mm)		50PCS	⑭	SCREW (M4*35mm)		4PCS
⑦	WOOD DOWEL (M8*30mm)		24PCS	⑮	ALLEN KEY		1PC
⑧	GLIDE	 	2PCS	⑯	ALLEN KEY		1PC

NOTE:

Phillips head screw driver is required in the assembly process; however, manufacturer does not provide this item.

STEP 1

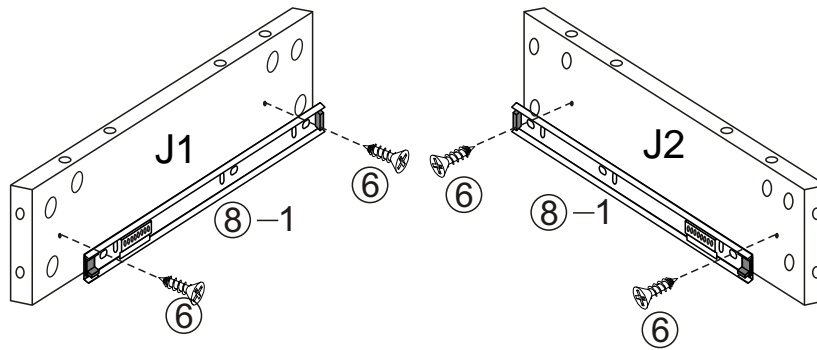
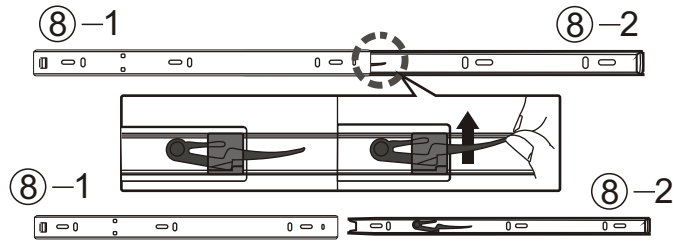

STEP 2

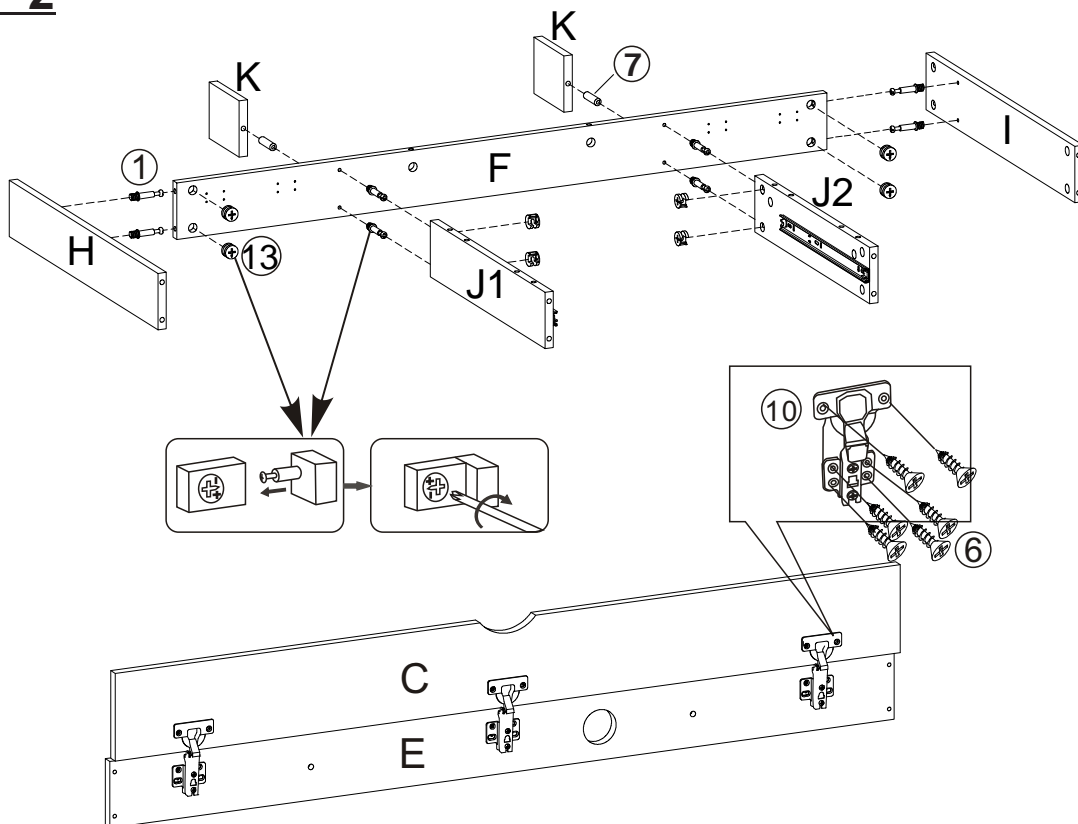

ITEM: **801935**

STEP 3

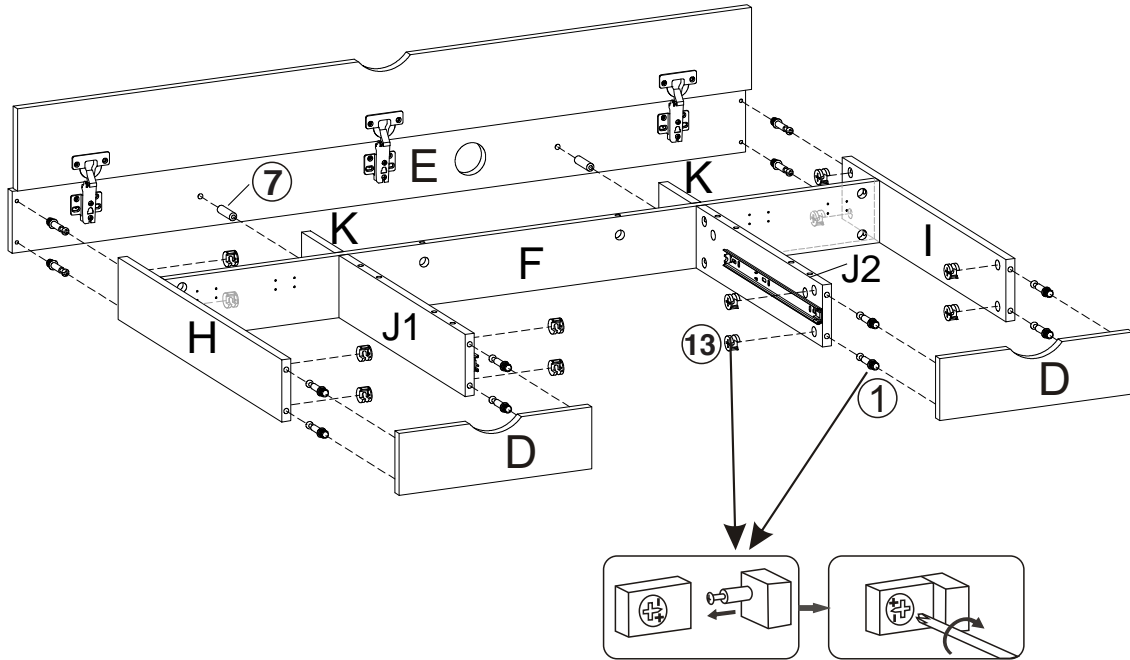

STEP 4

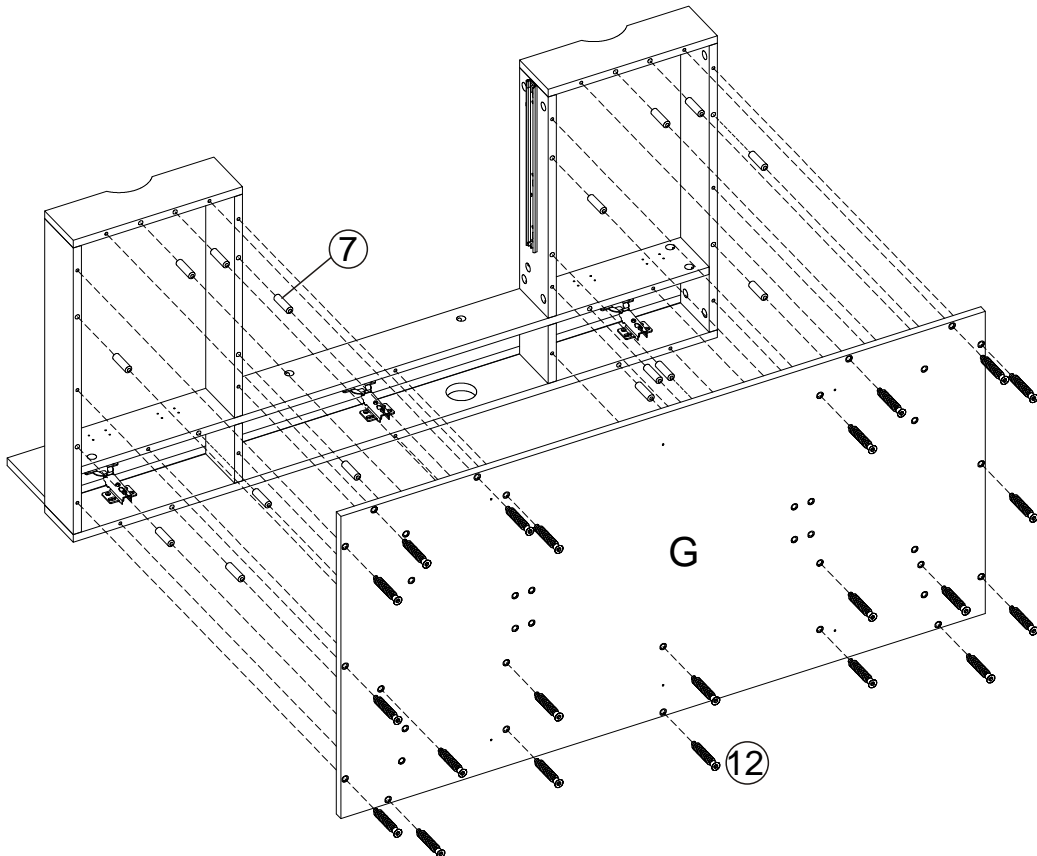

ITEM: **801935**



STEP 5

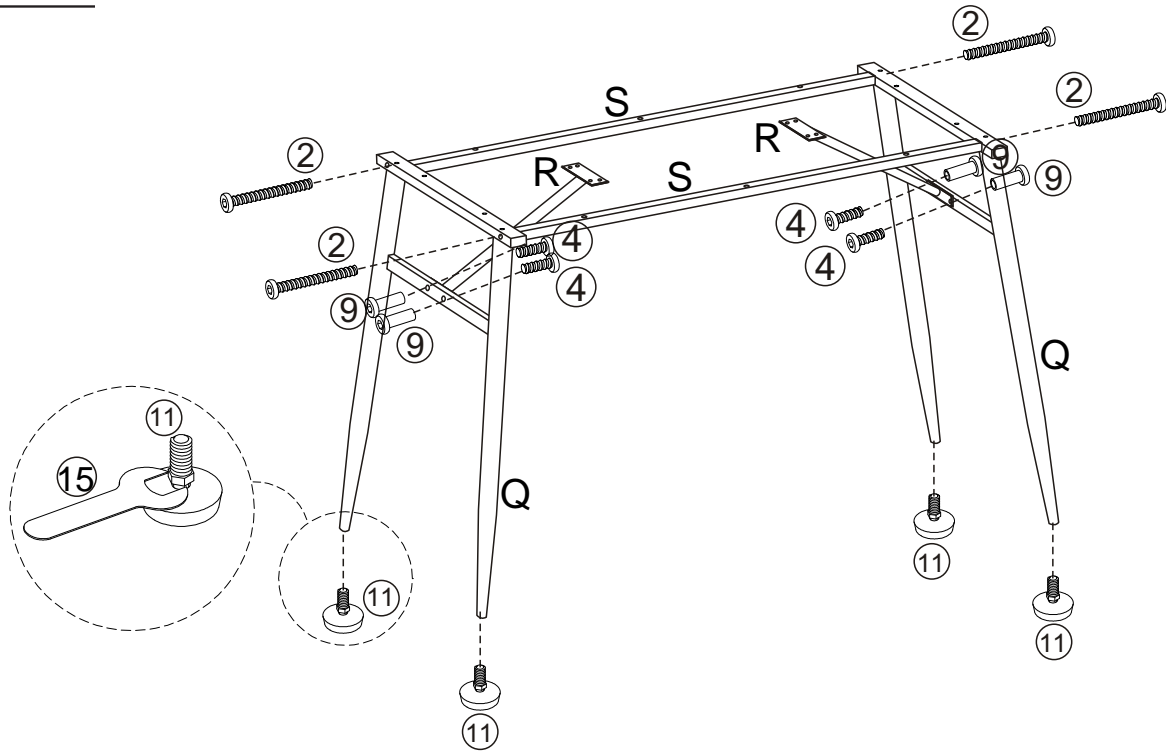

STEP 6

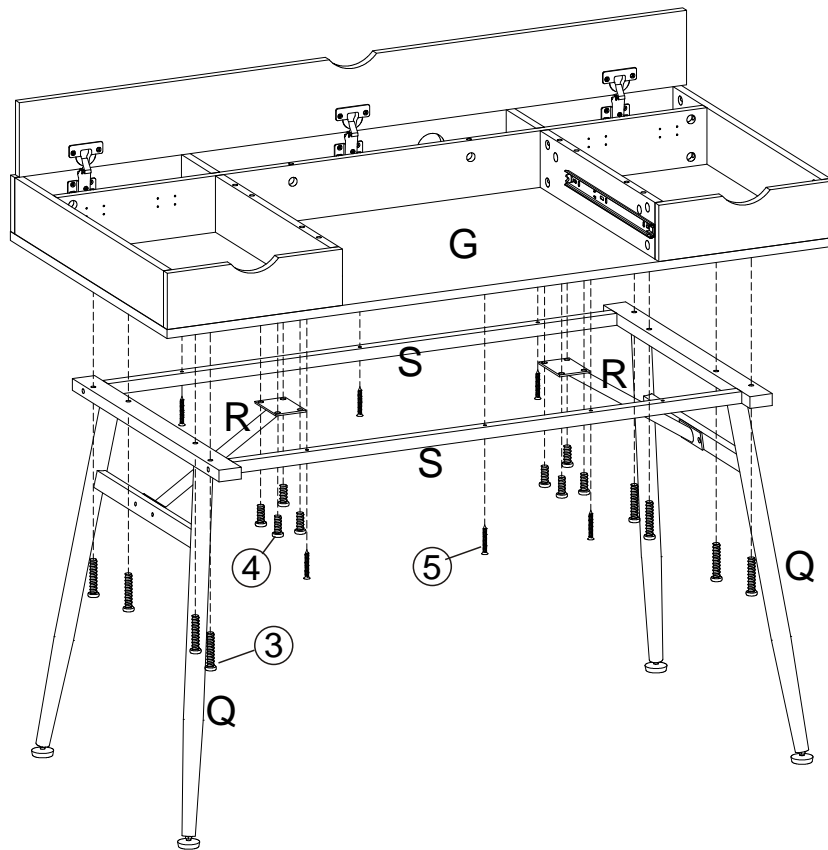

ITEM: **801935**



STEP 7

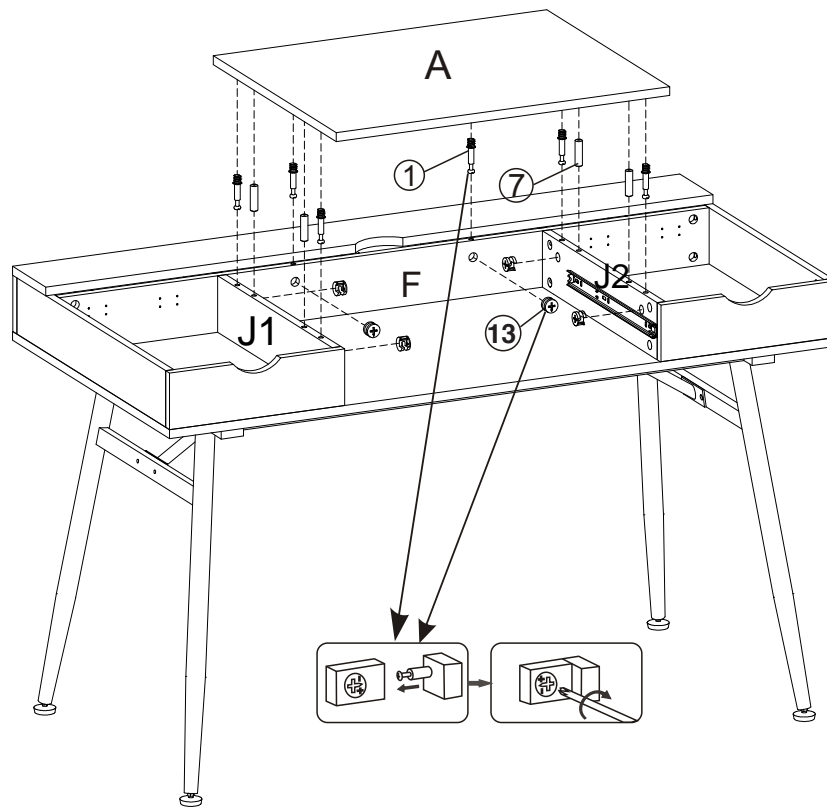

STEP 8

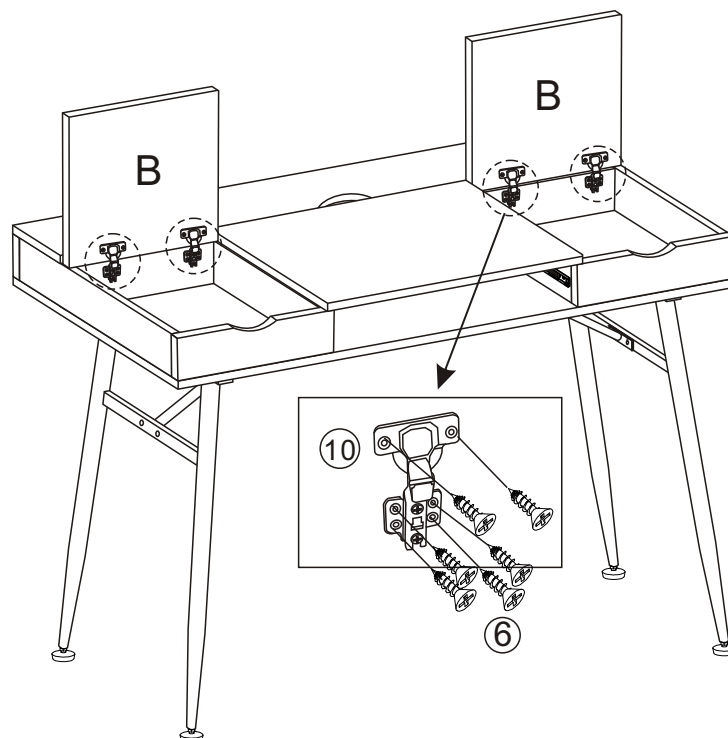

ITEM: 801935

STEP 9

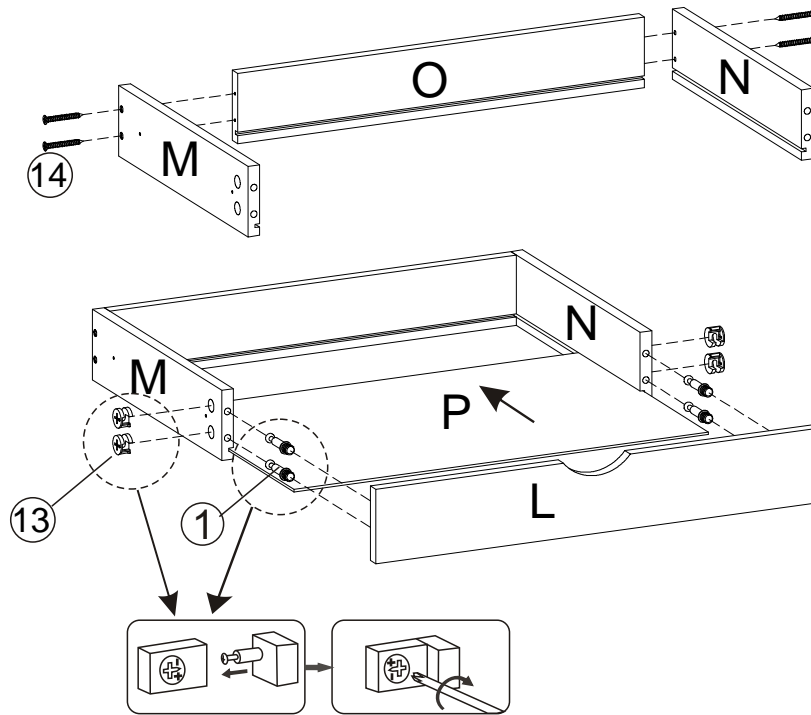

STEP 10

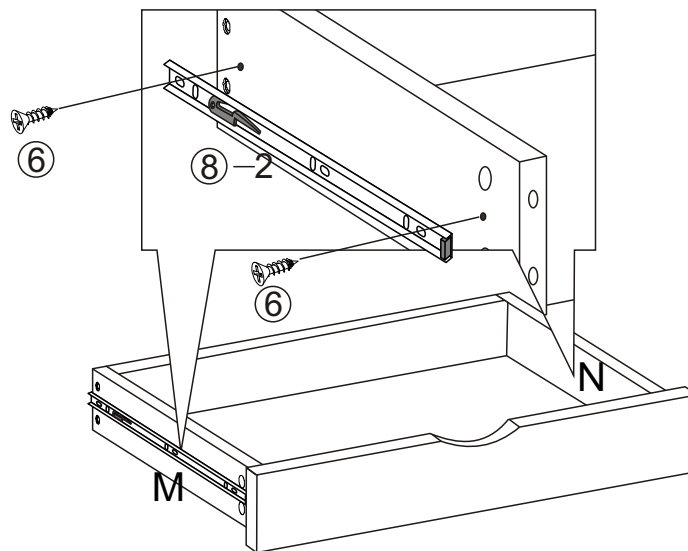

ITEM: **801935**



STEP 11

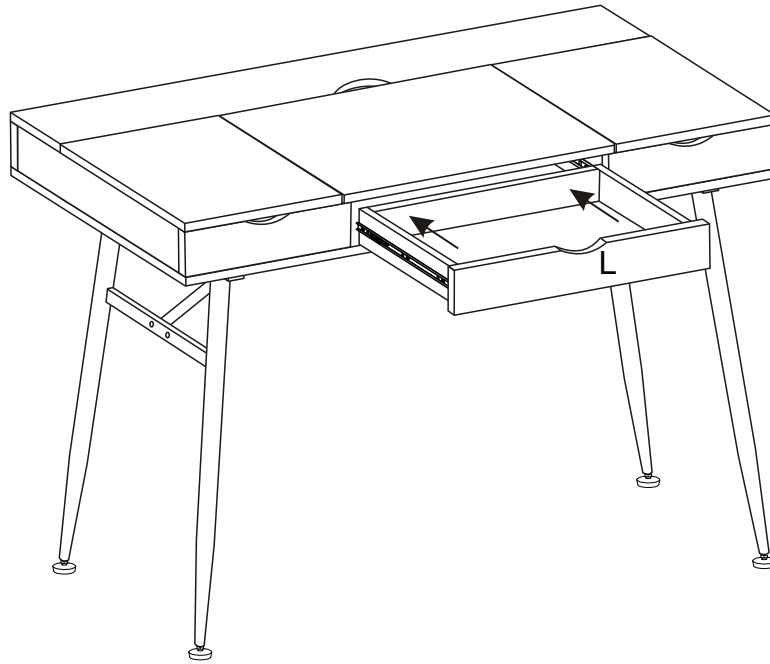

STEP 12
COMPLETE

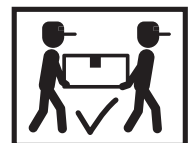
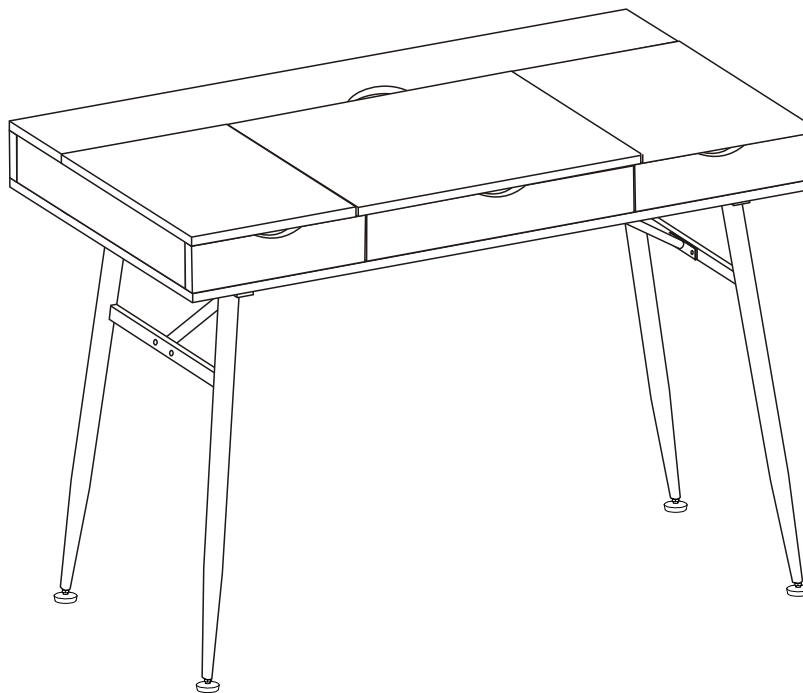

ITEM: **801935**

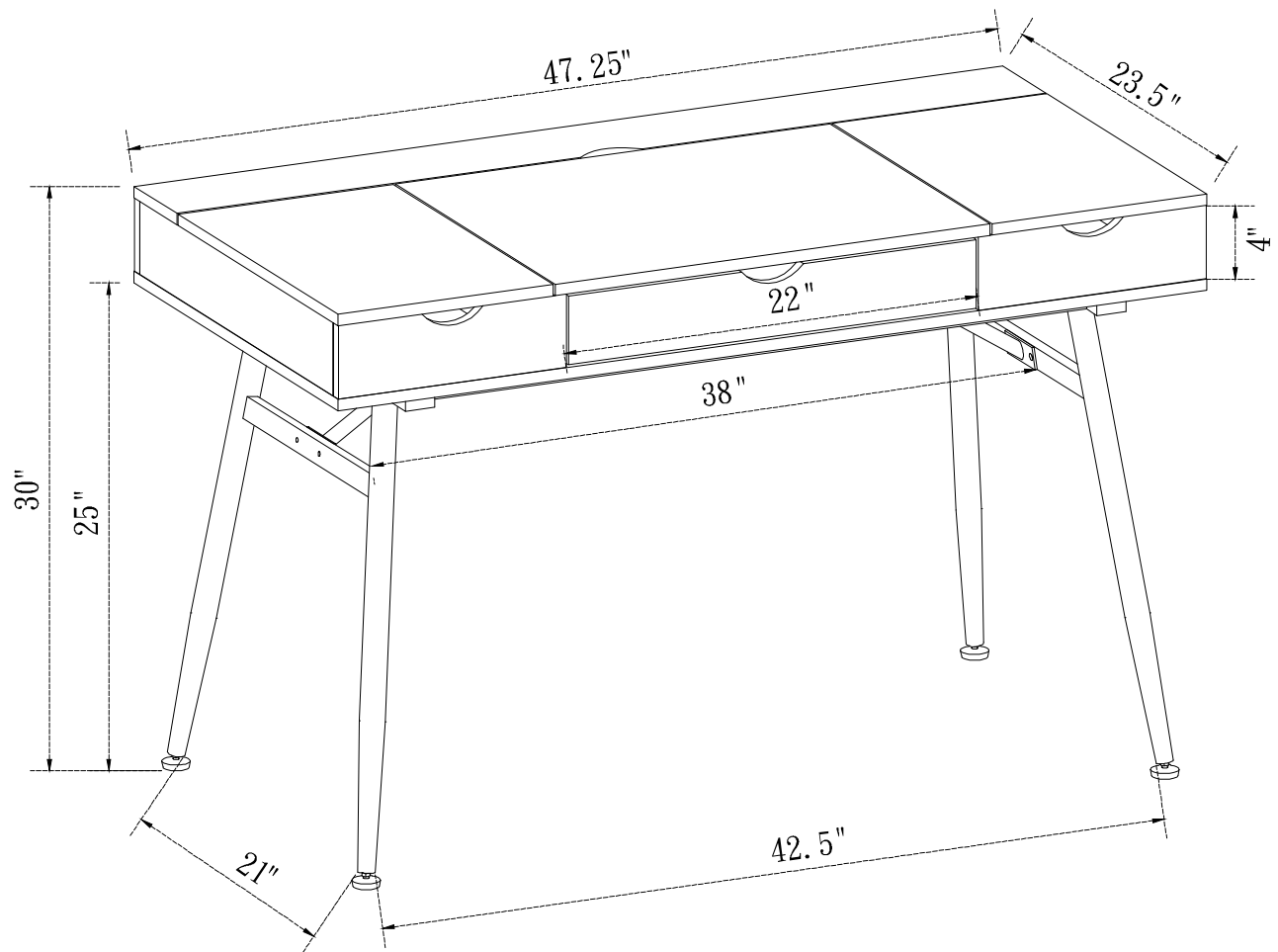

Note: Dimension tolerance $\pm 5\%$