



ASSEMBLY INSTRUCTIONS COASTER FINE FURNITURE



Fine Furniture for every stage of life

REVISION 0: 01/03/2021
REVISION 1: 07/18/2022

181065 Serving Cart

ITEM: 181065



ASSEMBLY INSTRUCTIONS

ASSEMBLY TIPS:

1. Remove hardware from box and sort by size.
2. Please check to see that all hardware and parts are present prior start of assembly.
3. Please follow attached instructions in the same sequence as numbered to assure fast & easy assembly.



WARNING!

1. Don't attempt to repair or modify parts that are broken or defective .Please contact the store immediately.
2. This product is for home use only and not intended for commercial establishment.





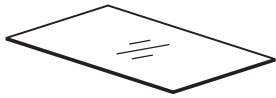
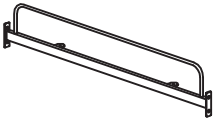
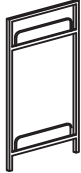

ASSEMBLY TIME

15 MINUTES

PARTS IDENTIFICATION

A	GLASS		2PCS	C	CONNECTION FRAME		4PCS
B	FRAME		2PCS				

HARDWARE IDENTIFICATION

Z	HARDWARE PACK		
1	1.5" WHEELS WITHOUT BRAKES		2PCS
2	1.5" WHEELS WITH BRAKE		2PCS
3	BOLT M6*12MM		16PCS
4	SUCTION CUP Ø20MM		8PCS
5	ALLEN WRENCH M4		1PC
6	SPANNER M14		1PC

ITEM: 181065

ASSEMBLY INSTRUCTIONS

STEP 1

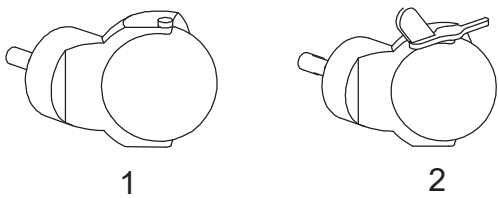
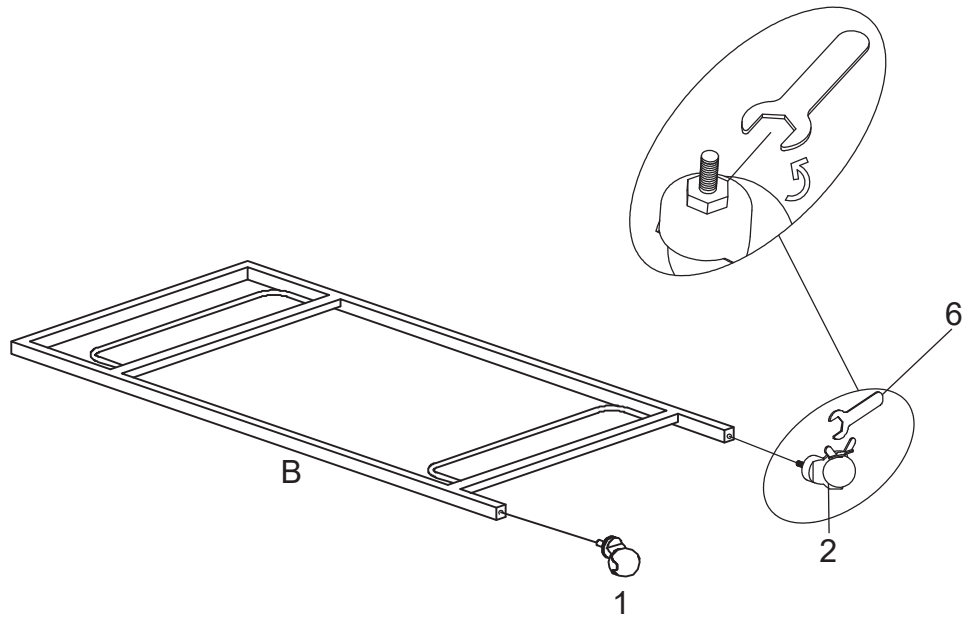

2x

STEP 2

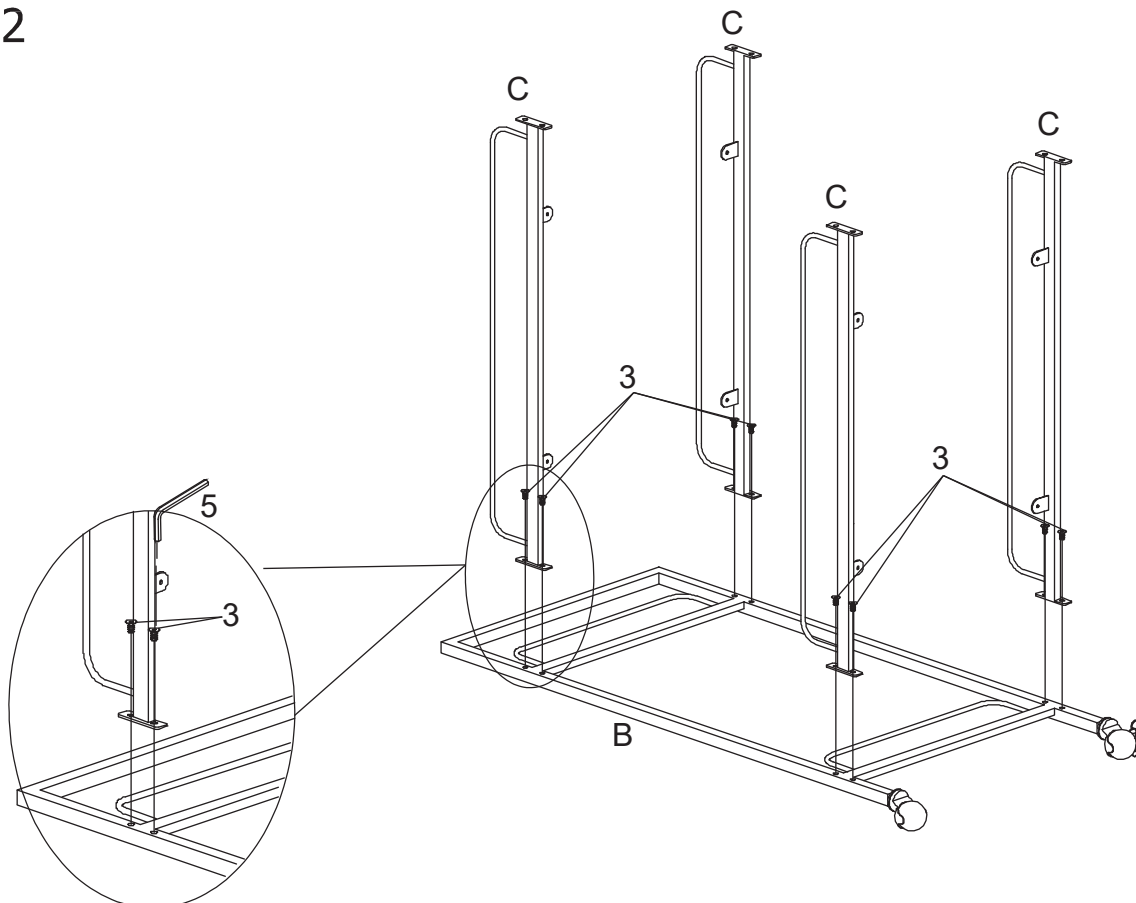

ITEM: 181065

ASSEMBLY INSTRUCTIONS

STEP 3

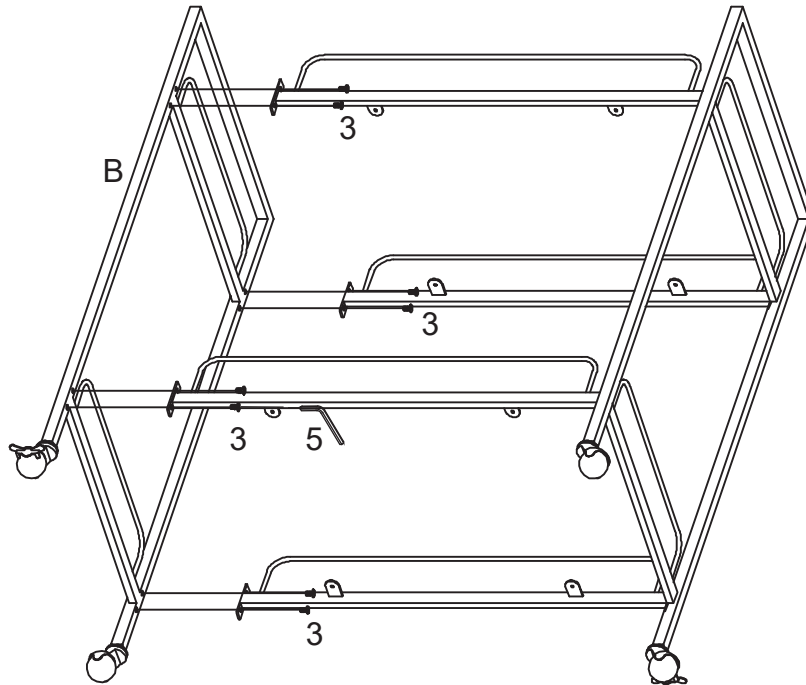

STEP 4

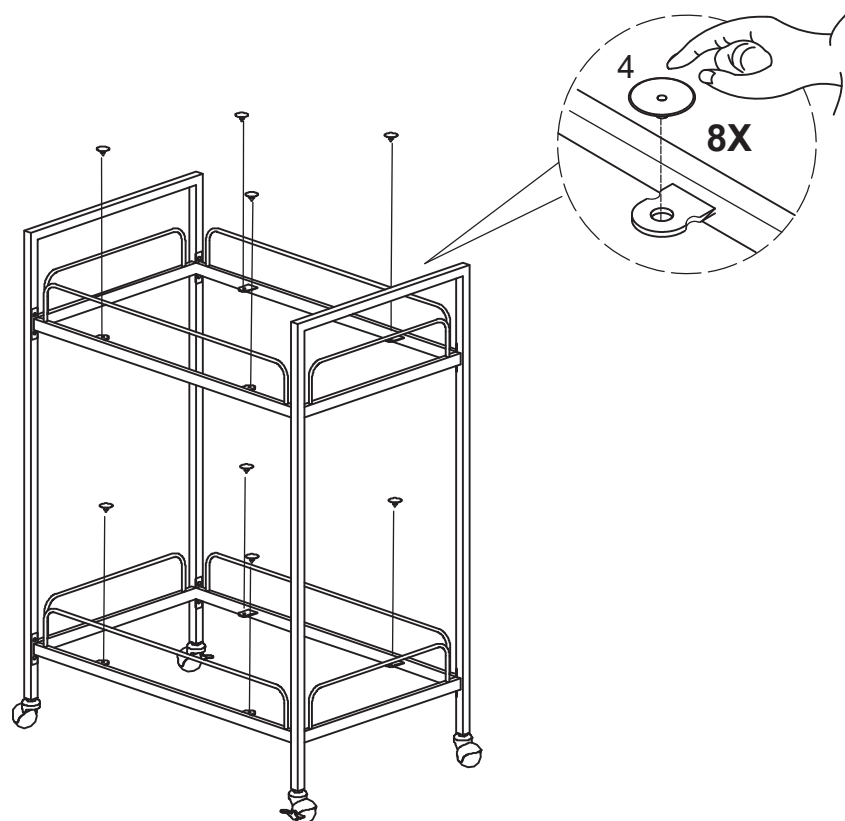

ITEM: 181065

ASSEMBLY INSTRUCTIONS

STEP 5

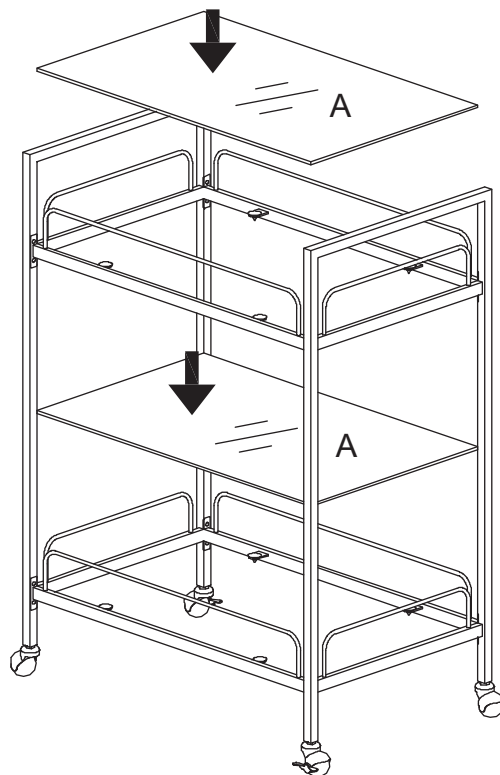

STEP 6

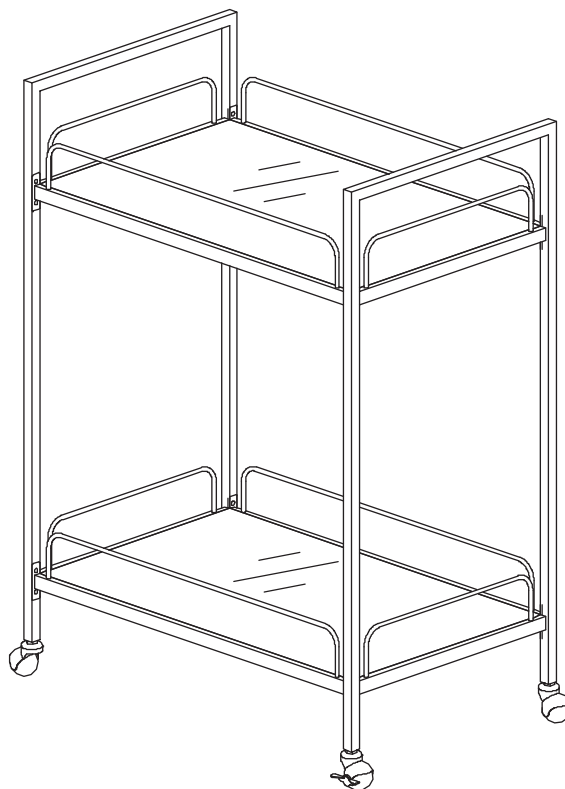

ITEM: 181065

ASSEMBLY INSTRUCTIONS

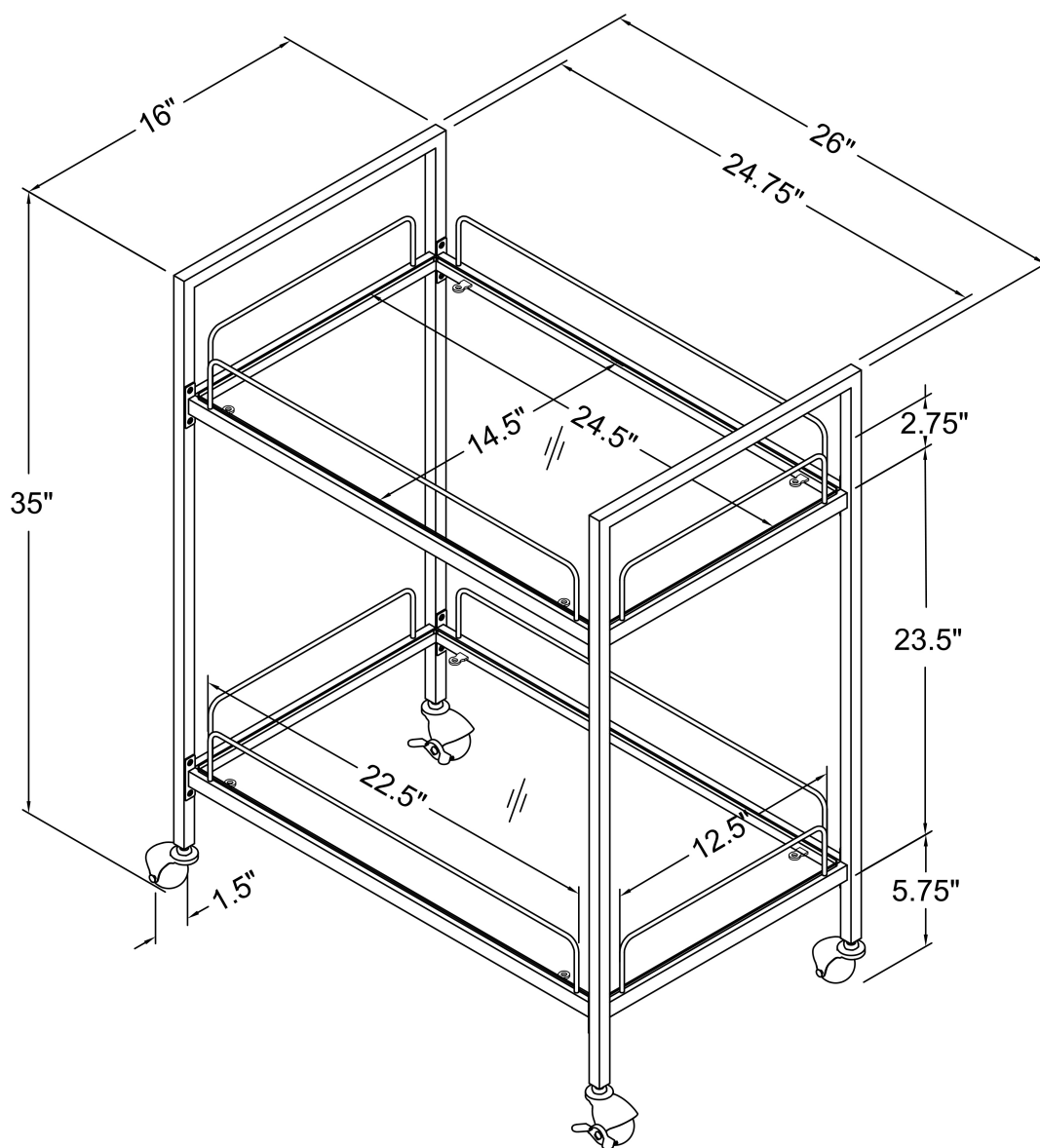

Note :Dimension tolerance $\pm 5\%$