

ASSEMBLY INSTRUCTIONS
COASTER FINE FURNITURE

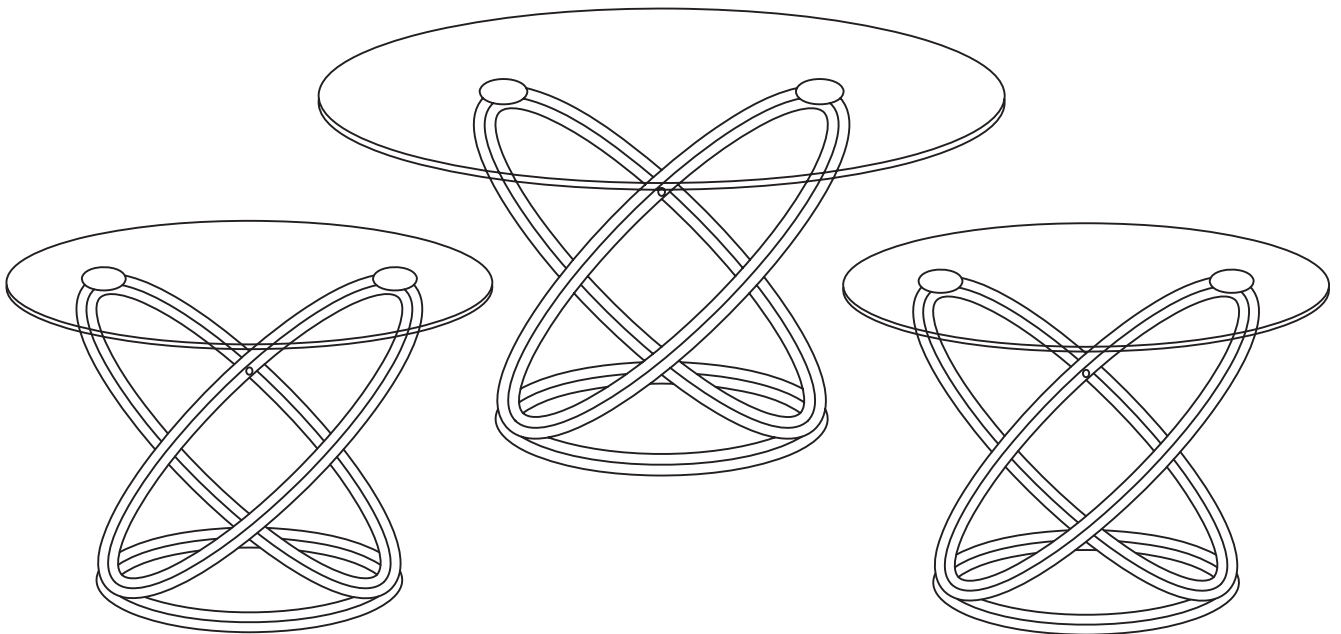

Fine Furniture for every stage of life

722373
3PC Set

ITEM: 722373



ASSEMBLY INSTRUCTIONS

ASSEMBLY TIPS:

1. Remove hardware from box and sort by size.
2. Please check to see that all hardware and parts are present prior to start of assembly.
3. Please follow attached instructions in the same sequence as numbered to assure fast & easy assembly.



WARNING!



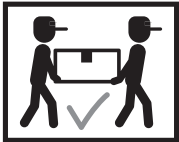



1. Don't attempt to repair or modify parts that are broken or defective. Please contact the store immediately.
2. This product is for home use only and not intended for commercial establishments.



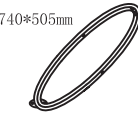

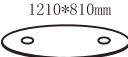



ASSEMBLY TIME

6 MINUTES

PARTS IDENTIFICATION

A	BIG METAL FRAME 1		1PC
B	BIG METAL FRAME 2		1PC
C	BIG CIRCLE FRAME		1PC
D	BIG TOP GLASS		1PC
E	SMALL METAL FRAME 1		2PCS
F	SMALL METAL FRAME 2		2PCS
G	SMALL CIRCLE FRAME		2PCS
H	SMALL TOP GLASS		2PCS

Z HARDWARE IDENTIFICATION

	DESCRIPTION	FIGURE	Q'TY
1	EXTRA LONG BOLT M6*30		6PCS
2	LONG BOLT M6*25		12PCS
3	SHORT BOLT M6*10		12PCS
4	ADJUS TABLE LEG		24PCS
5	METAL WASHER		12PCS
6	ALLEN WRENCH		1PC

ITEM:722373

ASSEMBLY INSTRUCTIONS

STEP 1

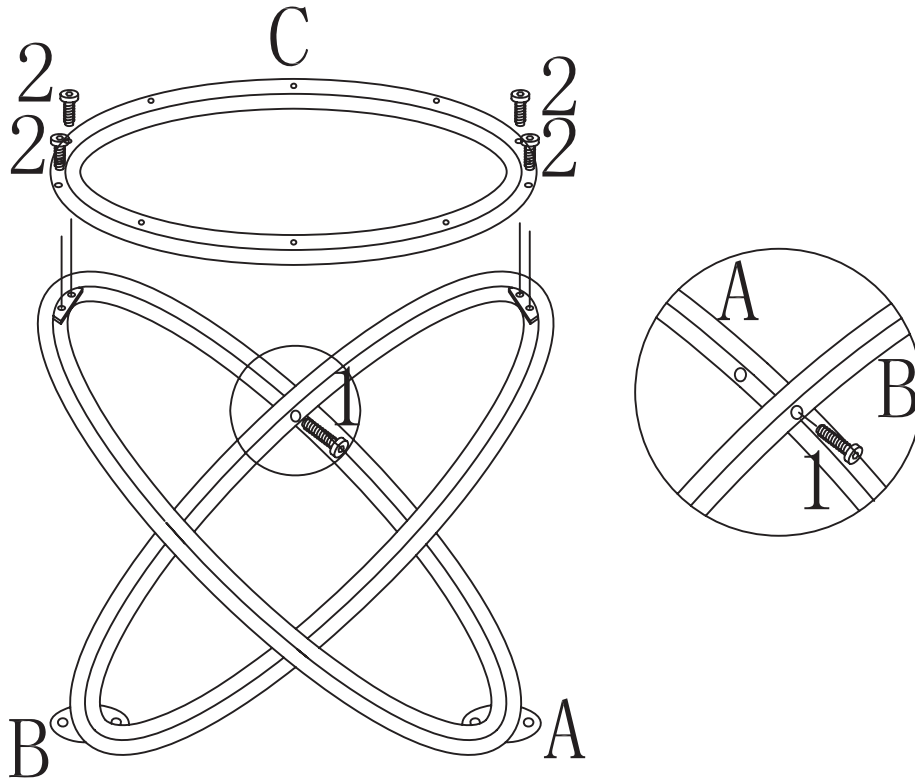

STEP 2

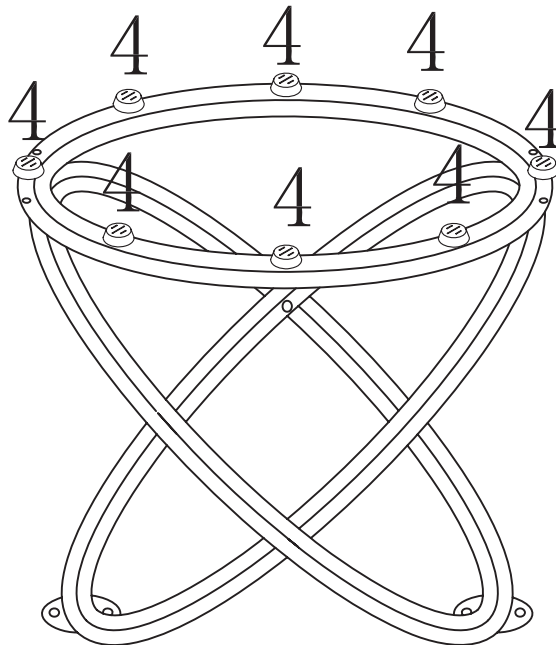

ITEM:722373

ASSEMBLY INSTRUCTIONS

STEP 3

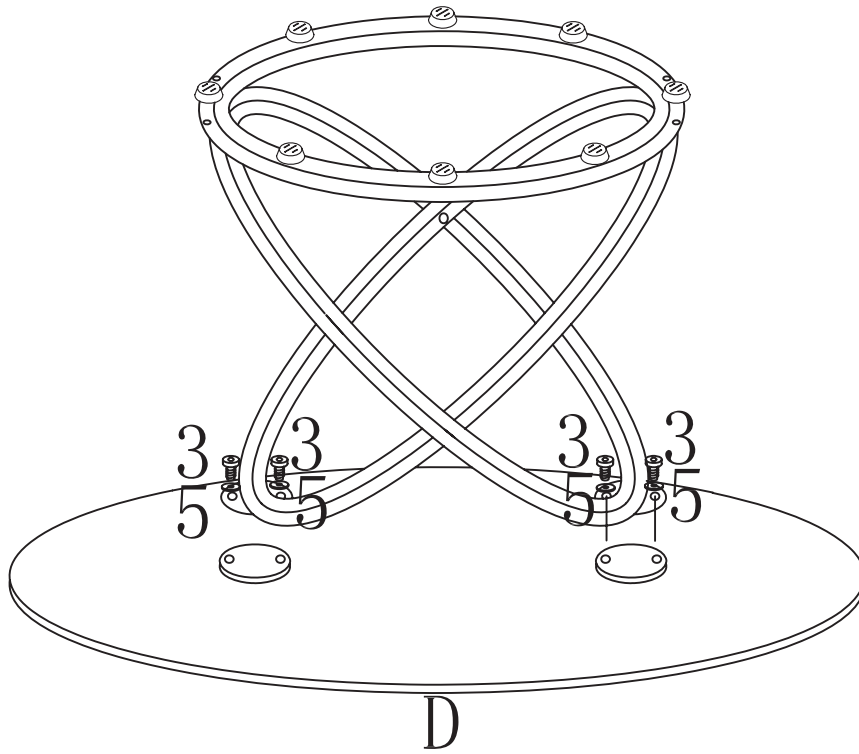

STEP 4

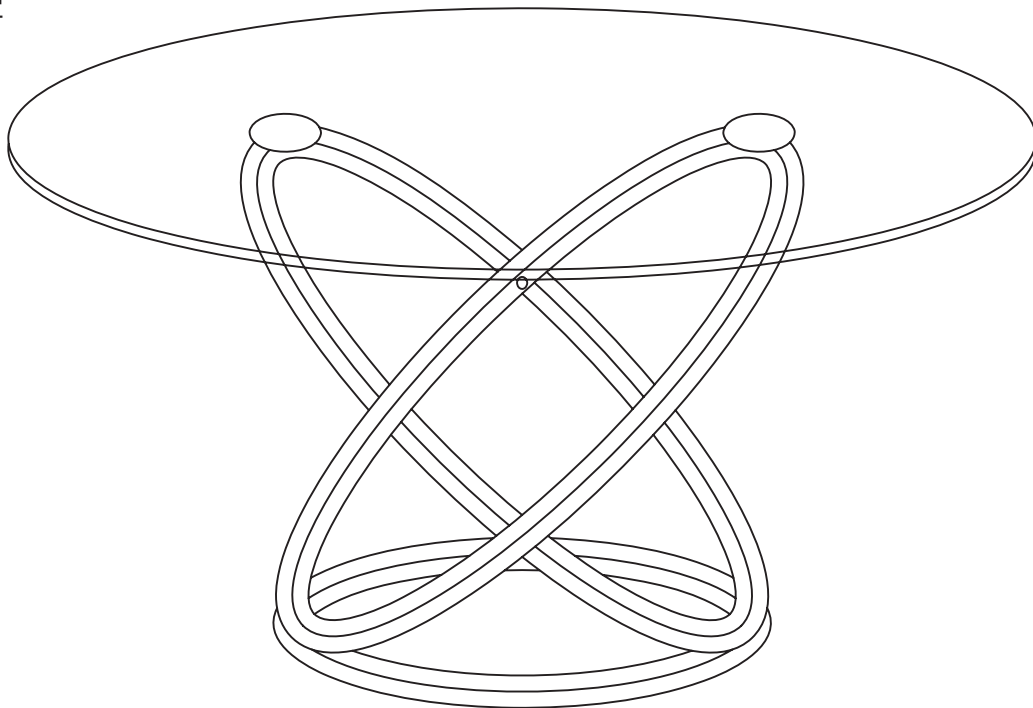

ITEM: 722373

ASSEMBLY INSTRUCTIONS

STEP 5

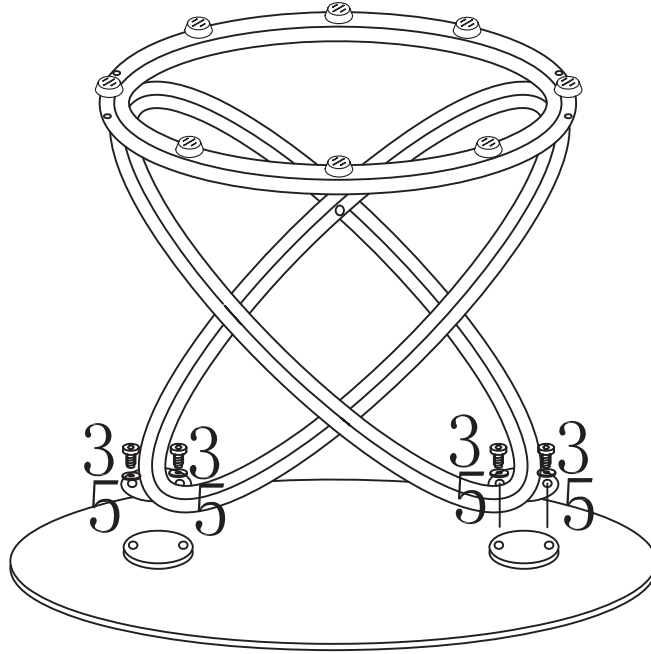

H

STEP 6

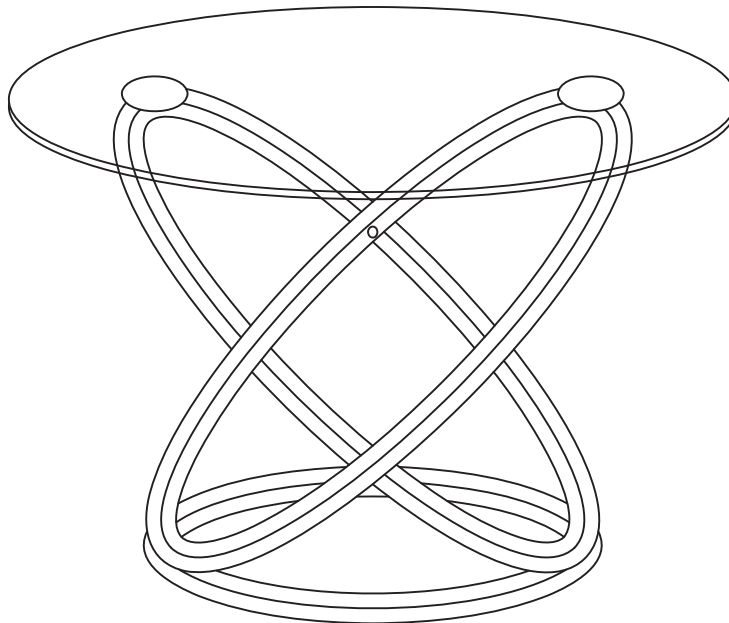

ITEM:722373

