

ASSEMBLY INSTRUCTIONS
COASTER FINE FURNITURE



Fine Furniture for every stage of life

700883
BRIDGE

ITEM: 700883

ASSEMBLY INSTRUCTIONS

ASSEMBLY TIPS:

1. Remove hardware from box and sort by size.
2. Please check to see that all hardware and parts are present prior to start of assembly.
3. Please follow attached instructions in the same sequence as numbered to assure fast & easy assembly.



WARNING!

1. Don't attempt to repair or modify parts that are broken or defective. Please contact the store immediately.
2. This product is for home use only and not intended for commercial establishments.



ASSEMBLY TIME

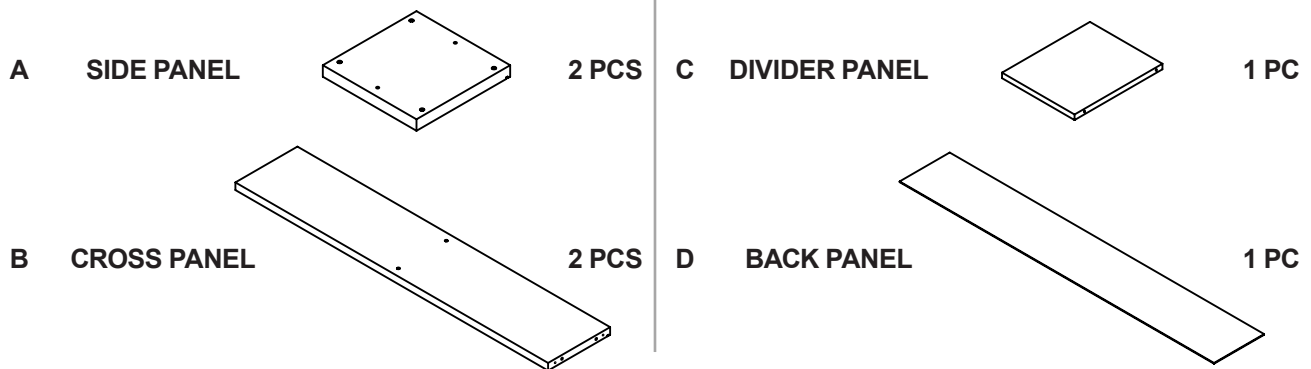

20 MINUTES

PARTS IDENTIFICATION

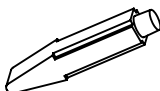
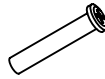
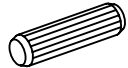

Z

HARDWARE IDENTIFICATION

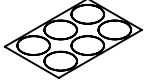
NO	DESCRIPTION	FIGURE	Q'TY	NO	DESCRIPTION	FIGURE	Q'TY
1	GLUE 15g		1PC	4	PIPE THREAD Ø 6.2x45mm SR		4PCS
2	WOODEN DOWEL Ø 8x30mm		8PCS	5	BOLT Ø 4.5x20mm SR		4PCS
3	CAM BOLT Ø 9.5x55mm SR FOR BOTTOM PANEL		12PCS	6	STICKER Ø 20mm		4PCS

NOTE:

Phillips head screw driver is required in the assembly process; however, manufacturer does not provide this item.

ITEM: 700883

STEP 1

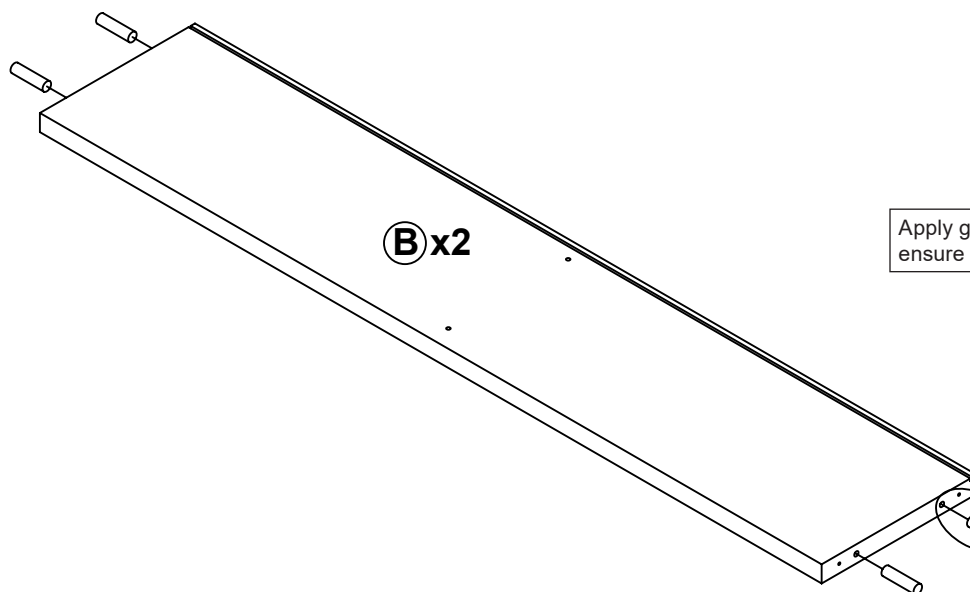
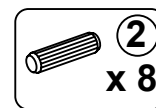

Apply glue on all wooden dowels to ensure integrity of the structure.

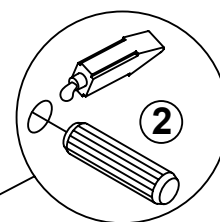

STEP 2

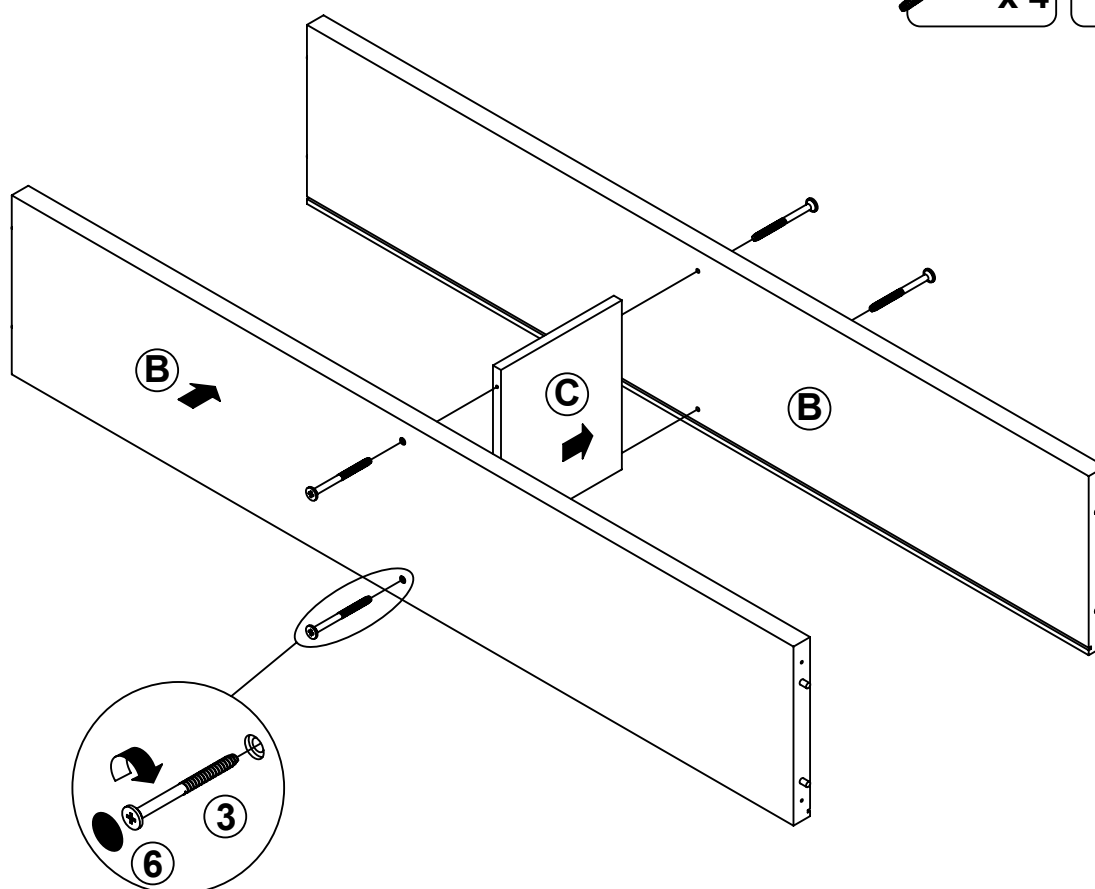
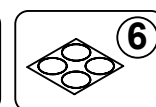
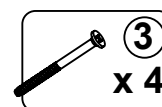

ITEM: **700883**

STEP 3

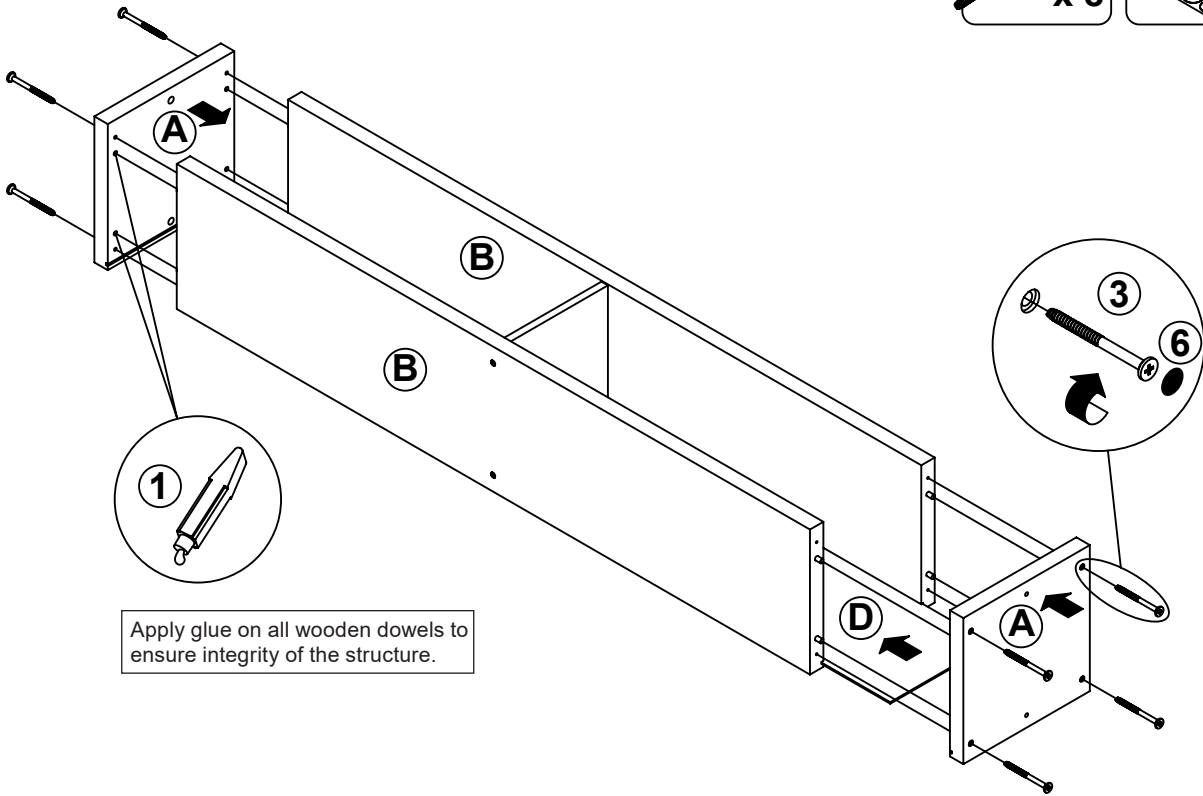
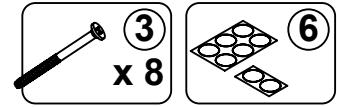

STEP 4

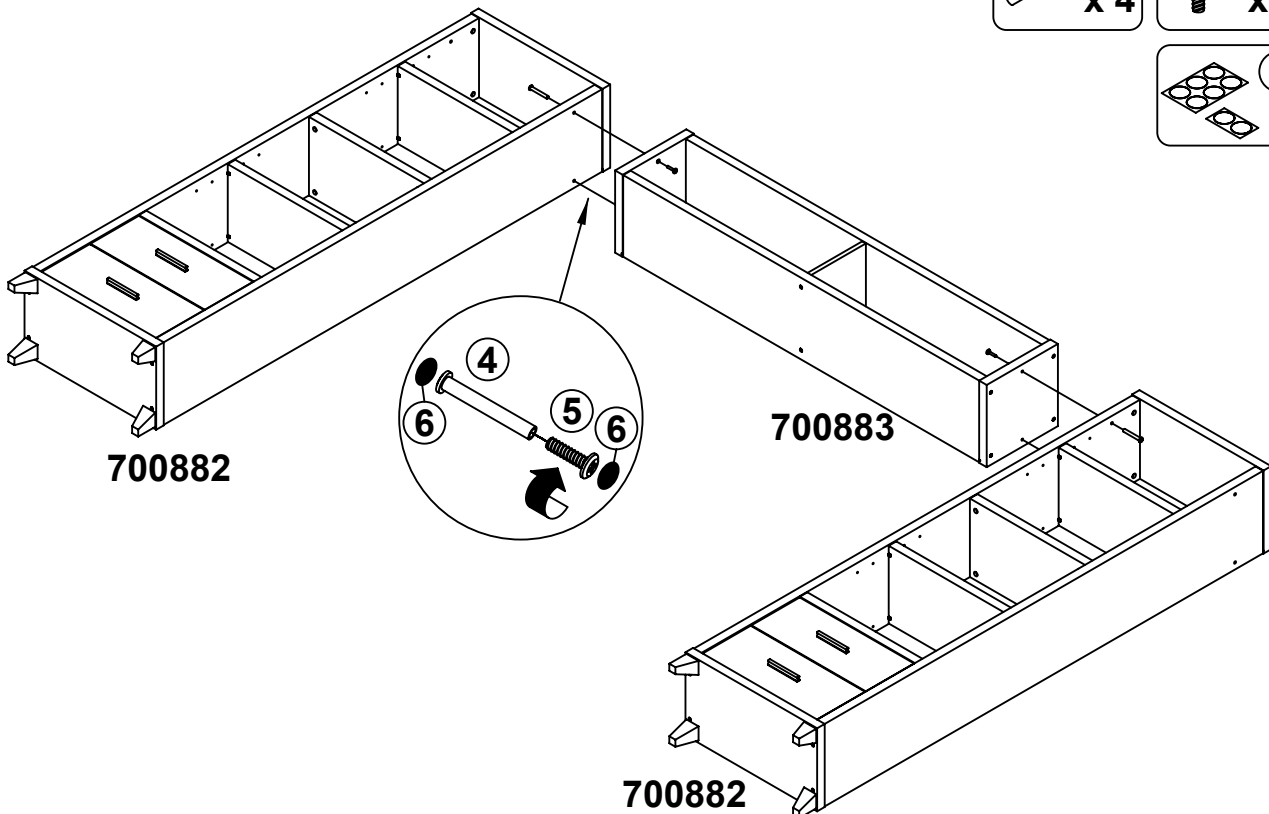
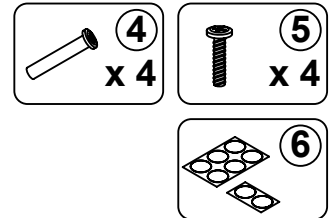

ITEM: **700883**

STEP 5

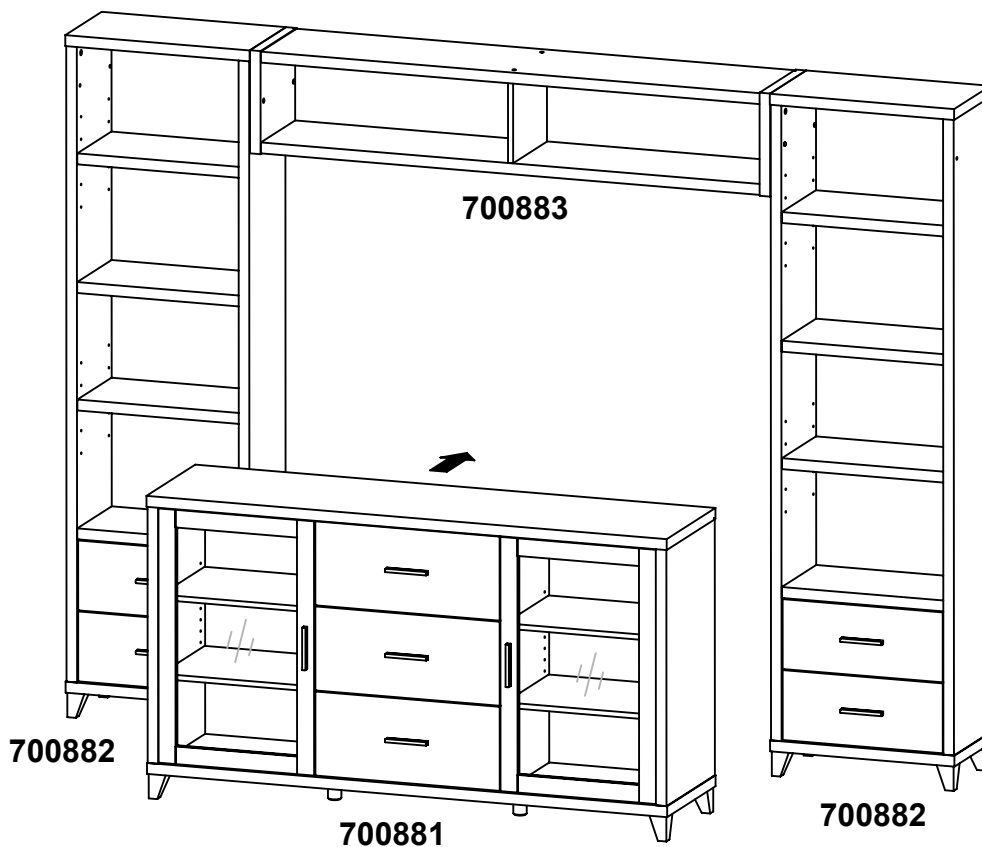

STEP 6

COMPLETE

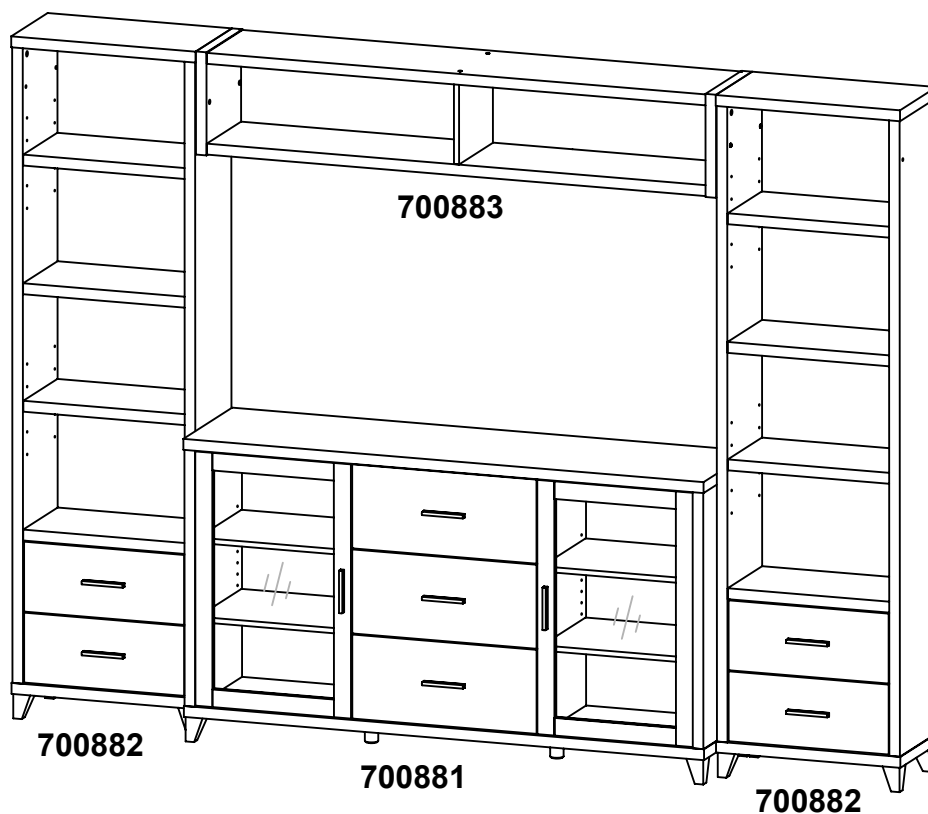

ITEM: 700883

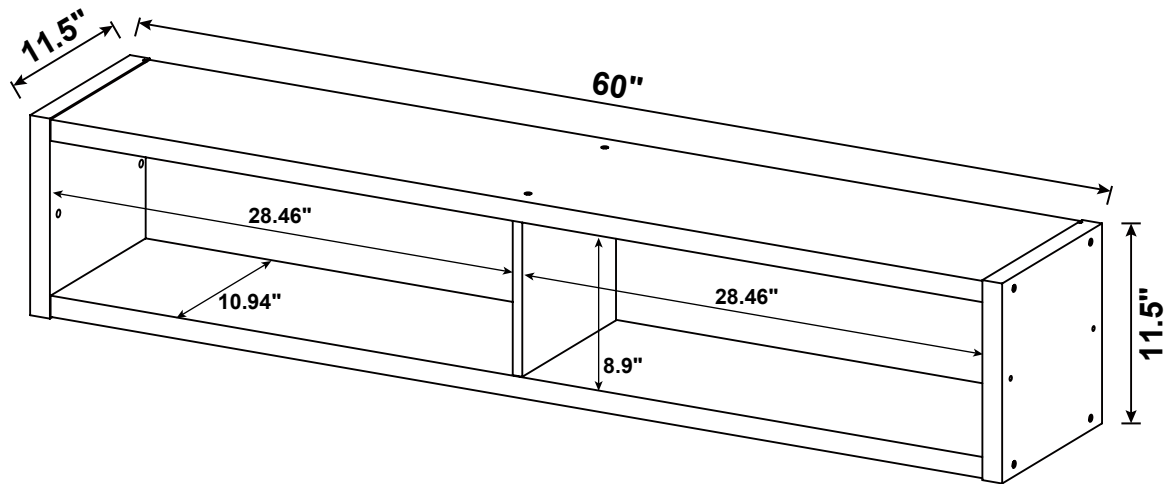

Note : Dimension tolerance $\pm 5\%$