

COASTER®

FINE FURNITURE

ASSEMBLY INSTRUCTIONS COASTER FINE FURNITURE



Fine Furniture for every stage of life

300629 (B1-B2)
DAY BED

REVISION 0 : 05/01/2019
REVISION 1 : 07/12/2019
REVISION 2 : 08/01/2019
REVISION 3 : 08/31/2022

ITEM:300629 (B1-B2)



ASSEMBLY INSTRUCTIONS

ASSEMBLY TIPS:

- 1.Remove hardware from box and sort by size.
- 2.Please check to see that all hardware and parts are present prior to start of assembly.
- 3.Please follow attached instructions in the same sequence as numbered to assure fast & easy assembly.



WARNING!

- 1.Don't attempt to repair or modify parts that are broken or defective. Please contact the store immediately.
- 2.This product is for home use only and not intended for commercial establishments.

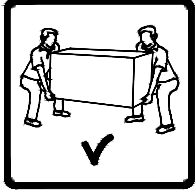

ASSEMBLY TIME

30 MINUTES

PARTS IDENTIFICATION

B1:(BOX 1)

A LEFT SIDE

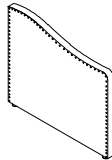

1PC

B RIGHT SIDE

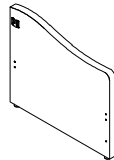

1PC

B2:(BOX 2)

C BACK

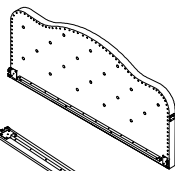

1PC

D FRONT RAIL

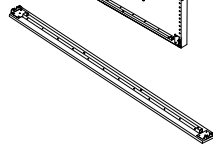

1PC

E METAL FRAME

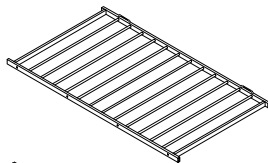

1PC

F FRONT PANEL

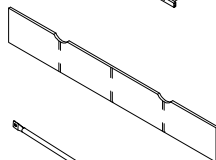

1PC

G SLATS

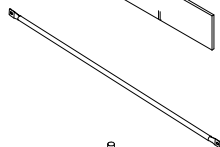

12PCS

H WHEEL



2PCS

I WHEEL WITH LOCK



2PCS

J STOPPER



2PCS

HARDWARE IDENTIFICATION:

Z-B2 (BOX 2) - HARDWARE PACK IS LOCATED IN 300629 (B2)

NO	DESCRIPTION	FIGURE	QTY
1	LARGE BOLT 5/16X1.5"-BLK		6PCS
2	MEDIUM BOLT 5/16X1"-BLK		8PCS
3	SMALL BOLT 1/4X0.63"-BLK		24PCS
4	FLAT WASHER 5/16"-BLK		14PCS
5	SMALL ALLEN WRENCH 1/4"-SLV		1PC
6	BIG ALLEN WRENCH 5/16"-SLV		1PC
7	WRENCH 5/16"-SLV		1PC

step1

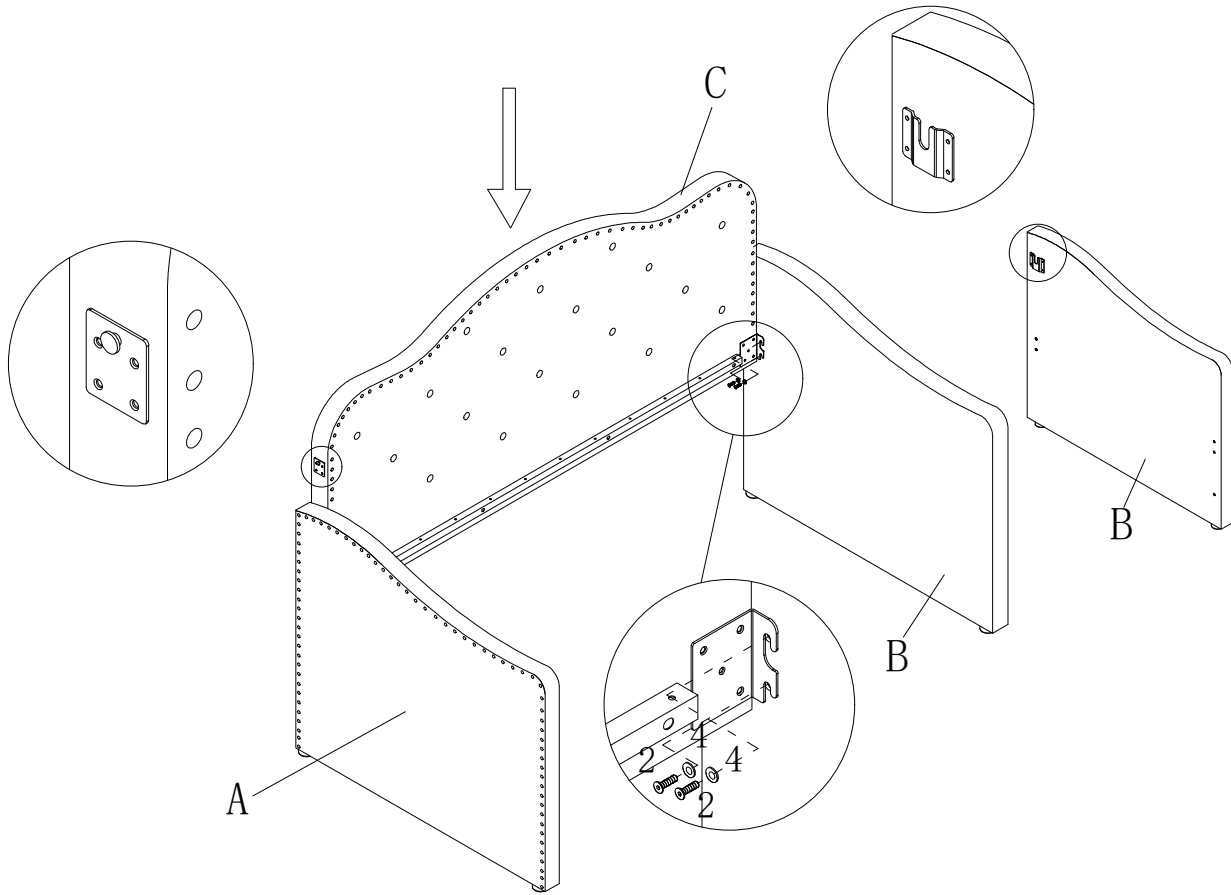

step2

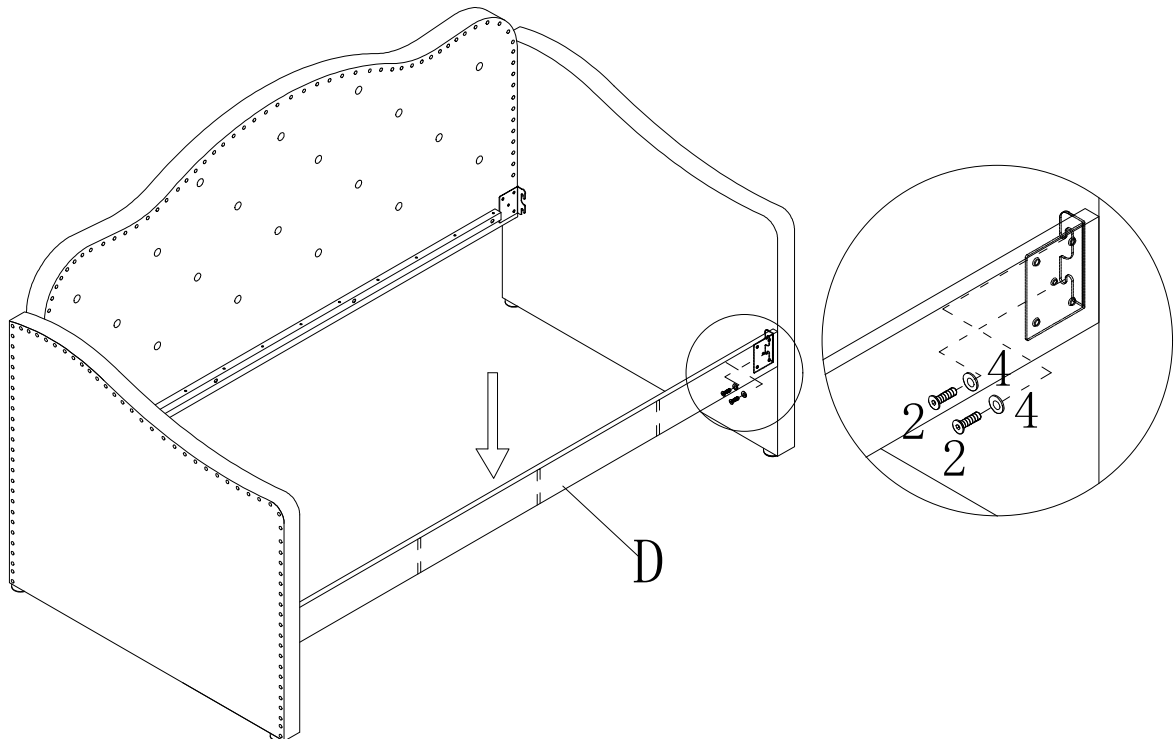

ITEM:300629 (B1-B2)
ASSEMBLY INSTRUCTIONS
step3

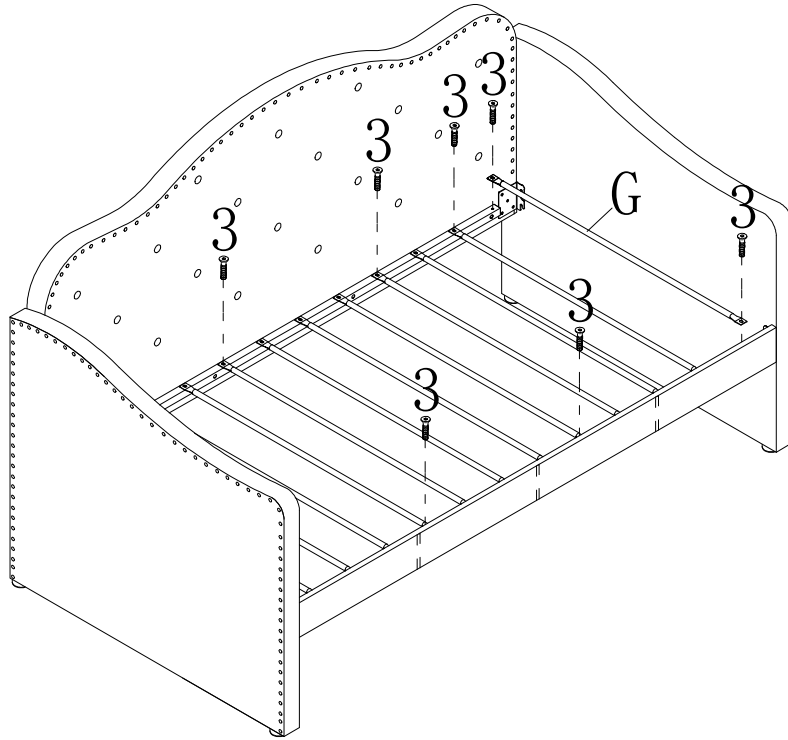

step4

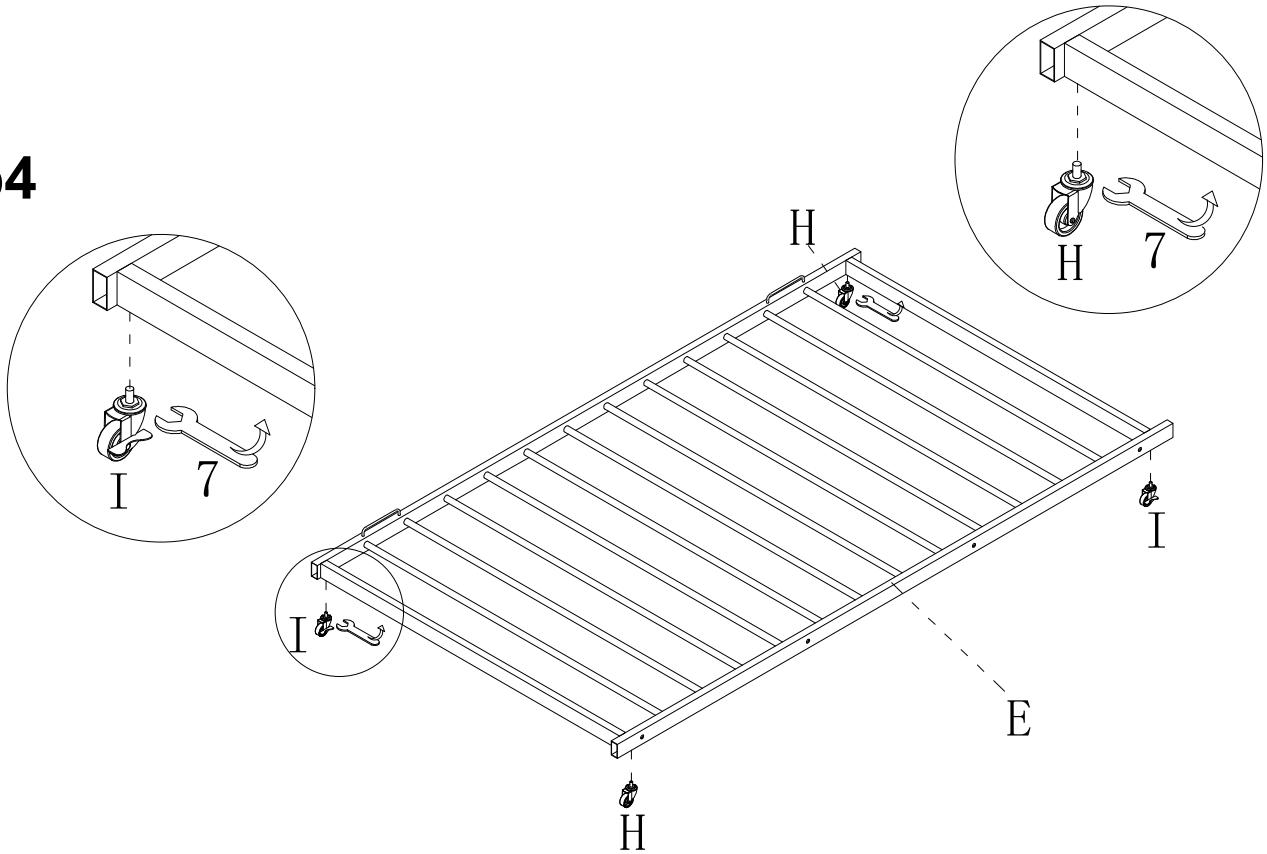

ITEM:300629 (B1-B2)
ASSEMBLY INSTRUCTIONS
step5

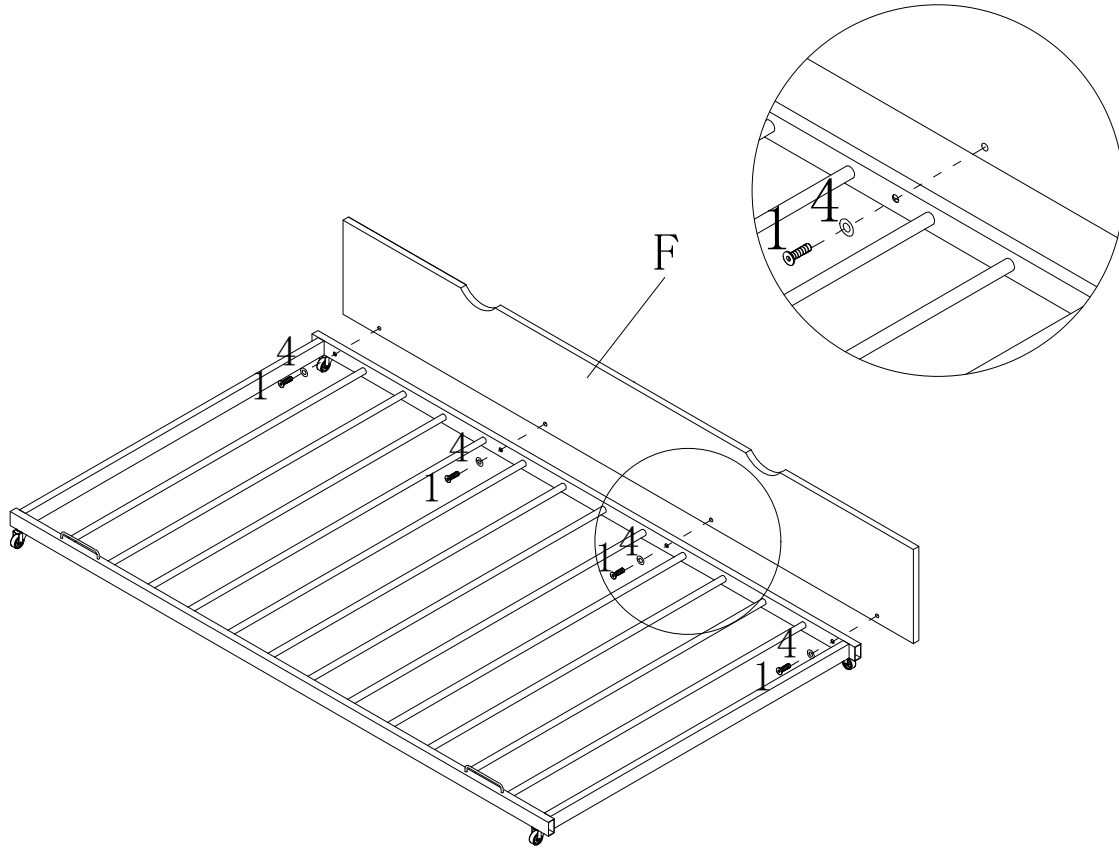

step6

