

**ASSEMBLY INSTRUCTIONS**  
**COASTER FINE FURNITURE**



*Fine Furniture for every stage of life*

**721881**  
**TV CONSOLE**

# ITEM: 721881



## ASSEMBLY INSTRUCTIONS

### ASSEMBLY TIPS:

1. Remove hardware from box and sort by size.
2. Please check to see that all hardware and parts are present prior to start of assembly.
3. Please follow attached instructions in the same sequence as numbered to assure fast & easy assembly.



### WARNING!

1. Don't attempt to repair or modify parts that are broken or defective. Please contact the store immediately.
2. This product is for home use only and not intended for commercial establishments.

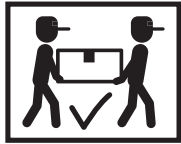

ASSEMBLY TIME

50 MINUTES

MAX TV SIZE: 65"

## PARTS IDENTIFICATION

A	LEFT SIDE PANEL		1 PC	H	LOWER BACK PANEL		1 PC
B	RIGHT SIDE PANEL		1 PC	I	DRAWER FRONT PANEL		2 PCS
C	MIDDLE DIVIDER PANEL		1 PC	J	DRAWER BACK PANEL		2 PCS
D	BOTTOM PANEL		1 PC	K	LEFT DRAWER SIDE PANEL		2 PCS
E	CROSS PANEL		1 PC	L	RIGHT DRAWER SIDE PANEL		2 PCS
F	TOP		1 PC	M	DRAWER BOTTOM PANEL		2 PCS
G	UPPER BACK PANEL		1 PC	N	DRAWER SUPPORT		2 PCS







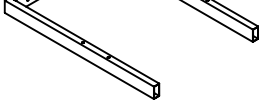

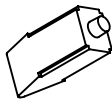

### NOTE:

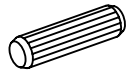
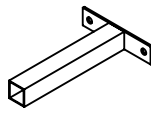
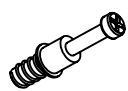
Phillips head screw driver is required in the assembly process; however, manufacturer does not provide this item.

ITEM:721881

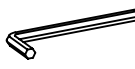
O LEG  2 PC

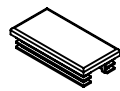
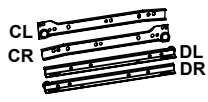
Z **HARDWARE IDENTIFICATION**

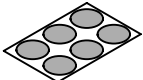
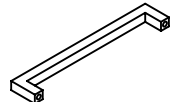
NO	DESCRIPTION	FIGURE	Q'TY	NO	DESCRIPTION	FIGURE	Q'TY
1	GLUE 40g		1 PC	10	HANDLE BOLT (Ø 4x28mm BLK)		4 PCS
2	WOODEN DOWEL Ø 8x30mm		24 PCS	11	SQUARE FOOT		1 PC
3	CAM BOLT (Ø 7x35.5mm SR)		14 PCS	12	SCREW (Ø 4x17mm RBW)		2 PCS
4	CAM LOCK (Ø 15x12mm SR)		14 PCS	13	LONG BOLT (M6x38mm BLK)		12 PCS
5	LONG SCREW (Ø 4.5x42mm SR)		6 PCS	14	ALLEN WRENCH (4mm SR)		1PC
6	SCREW (Ø 4.3x35mm SR)		10 PCS	15	FLOOR PROTECTOR 40x20mm		4 PCS
7	GLIDES (L = 300mm WHT)		2 SET	16	FLOOR PROTECTOR 18x18mm		1 PC
8	GLIDES SCREW (Ø 3x10mm SR)		24 PCS	17	STICKER Ø 20mm		3 PCS
9	HANDLE L = 137.5mm		2 PCS				





Z7,Z9,Z11 not included in blister packaging.

**NOTE:**

Phillips head screw driver is required in the assembly process; however, manufacturer does not provide this item.

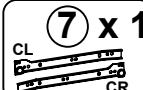
ITEM: 721881

**STEP 1**

- |   |   |  |
|---|---|--|
|  ②<br>x 8 |  ⑦ x 1<br>CL<br>CR |  ⑧<br>x 6 |
|  ⑬<br>x 8 |  ⑭                 |  ⑮<br>x 4 |

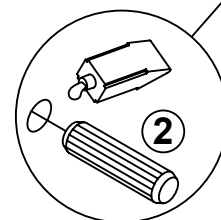
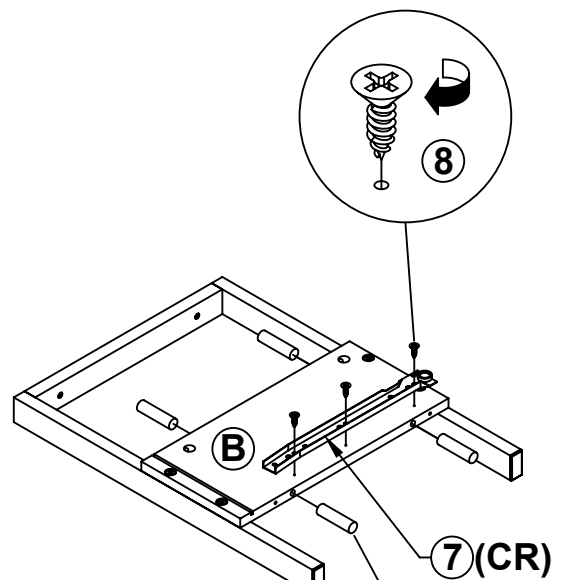
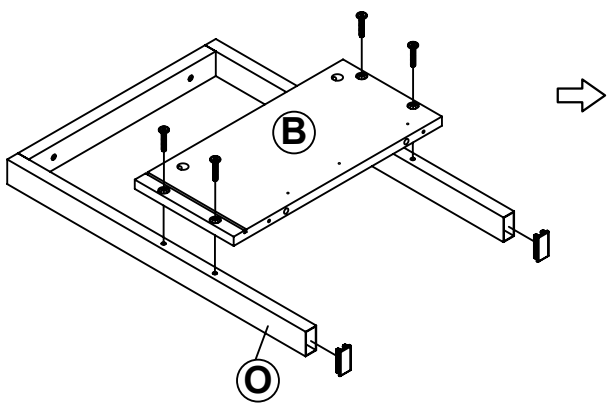
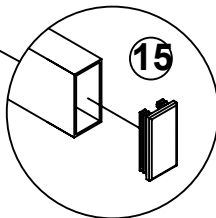
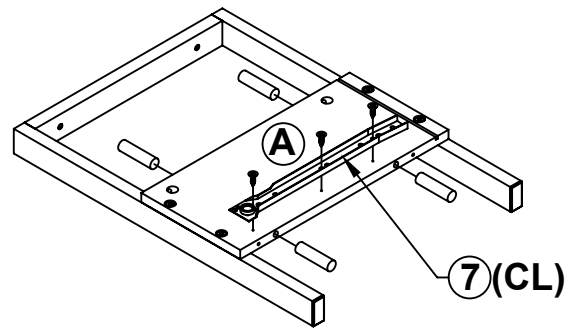
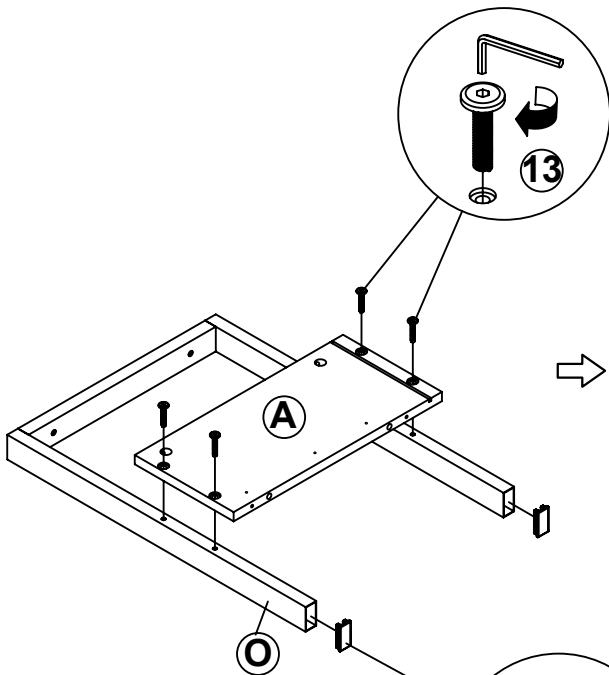

INCORRECT  
CORRECT

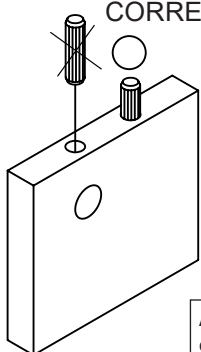

Apply glue on all wooden dowels to ensure integrity of the structure.

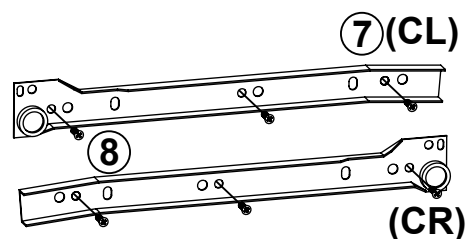

ITEM: 721881

**STEP 2**

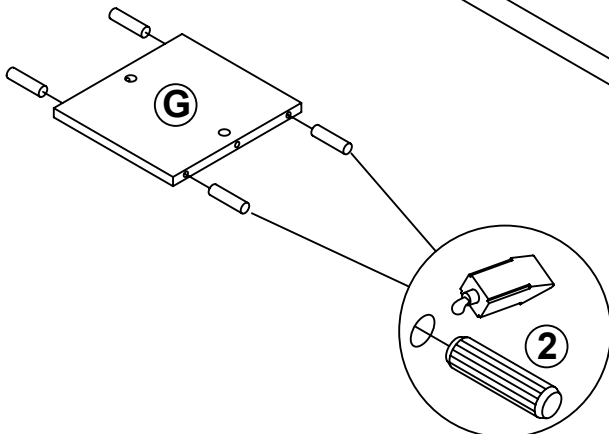
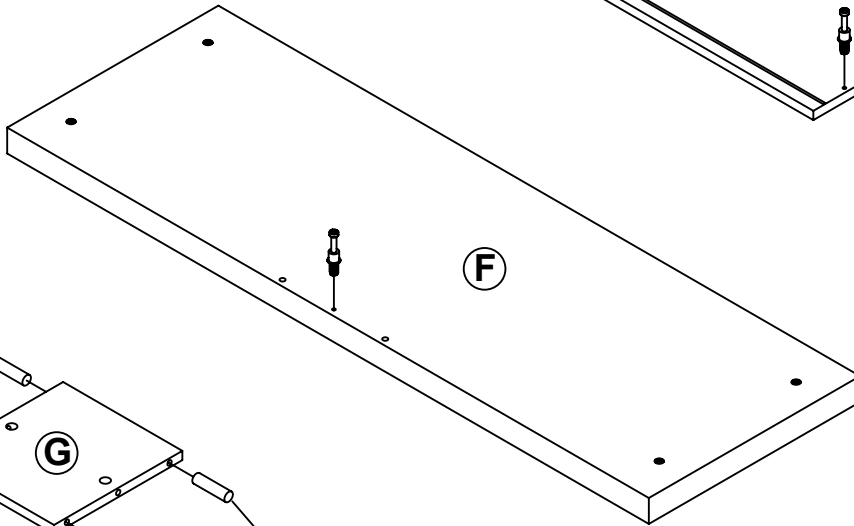
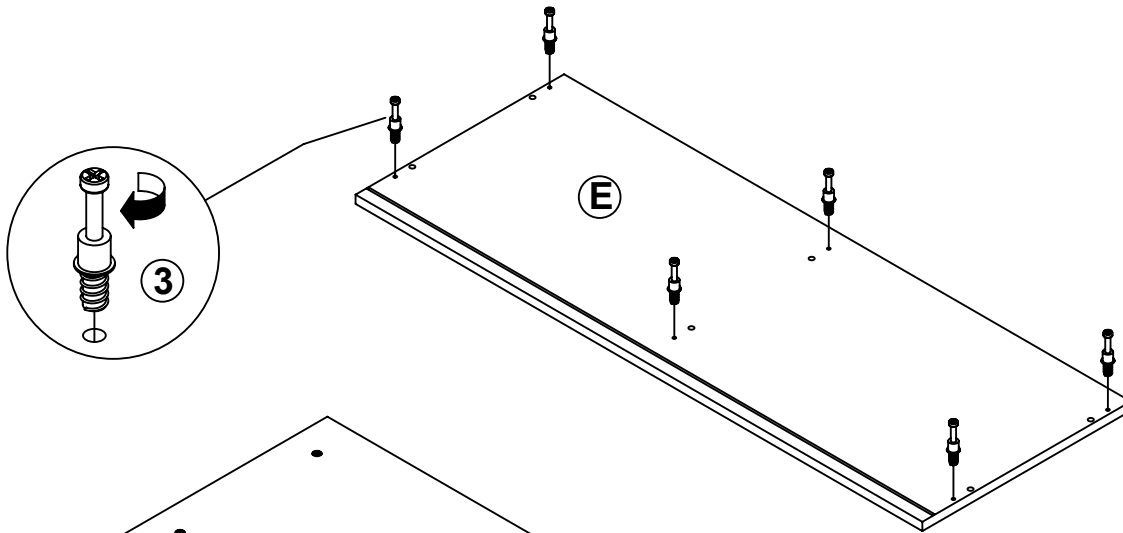
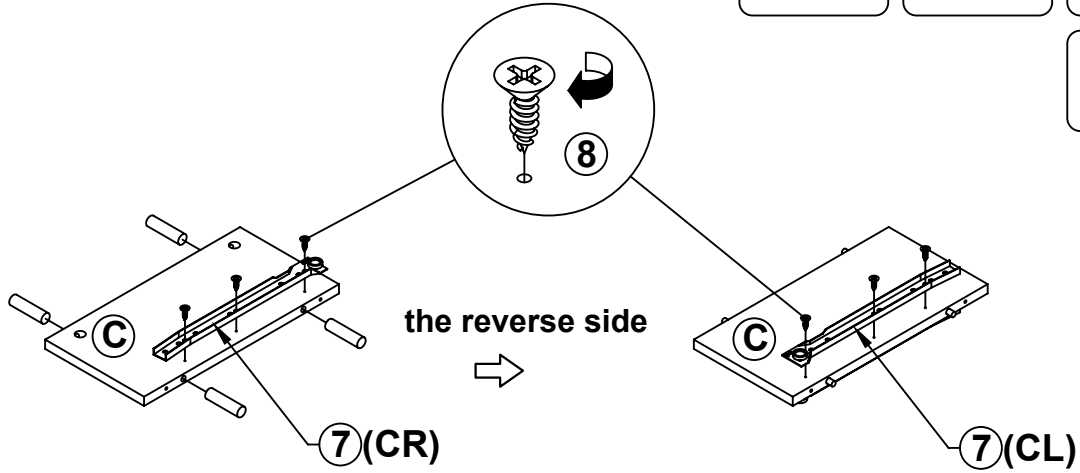
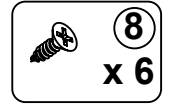
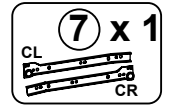
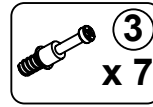
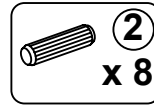

Apply glue on all wooden dowels to ensure integrity of the structure.

ITEM: 721881

**STEP 3**

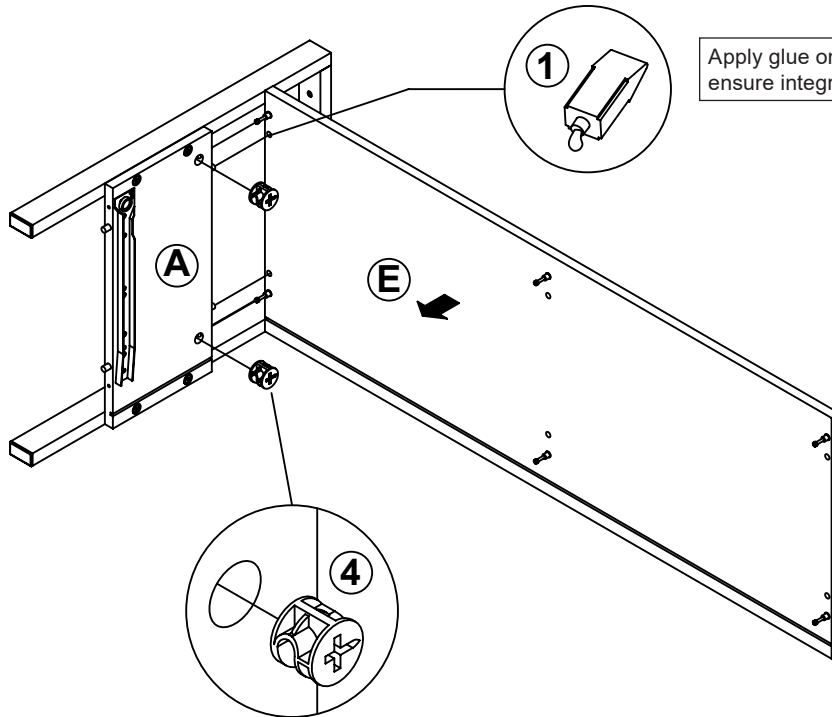
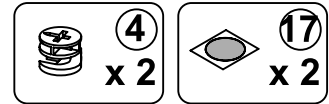

Apply glue on all wooden dowels to ensure integrity of the structure.

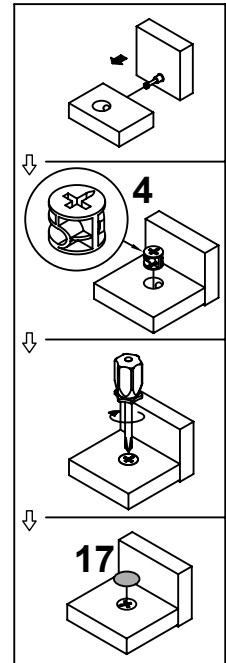

**STEP 4**

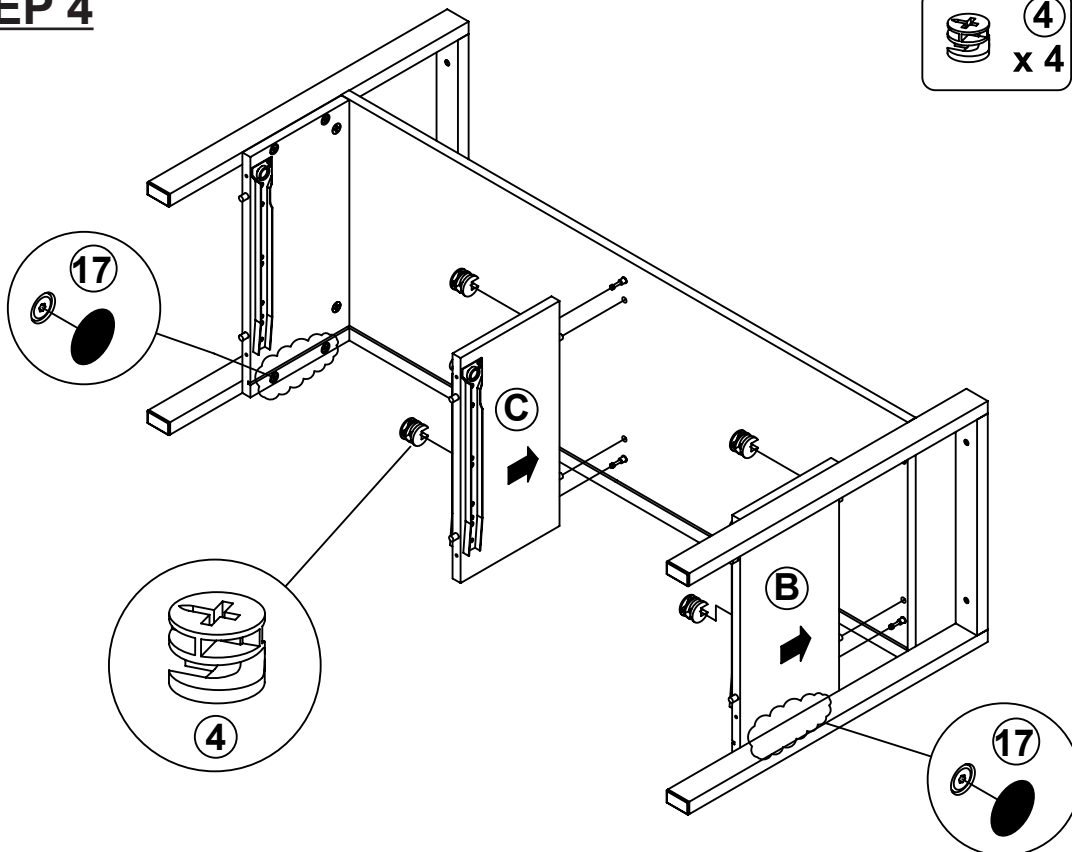

ITEM: 721881

**COASTER**  
FINE FURNITURE

**STEP 5**

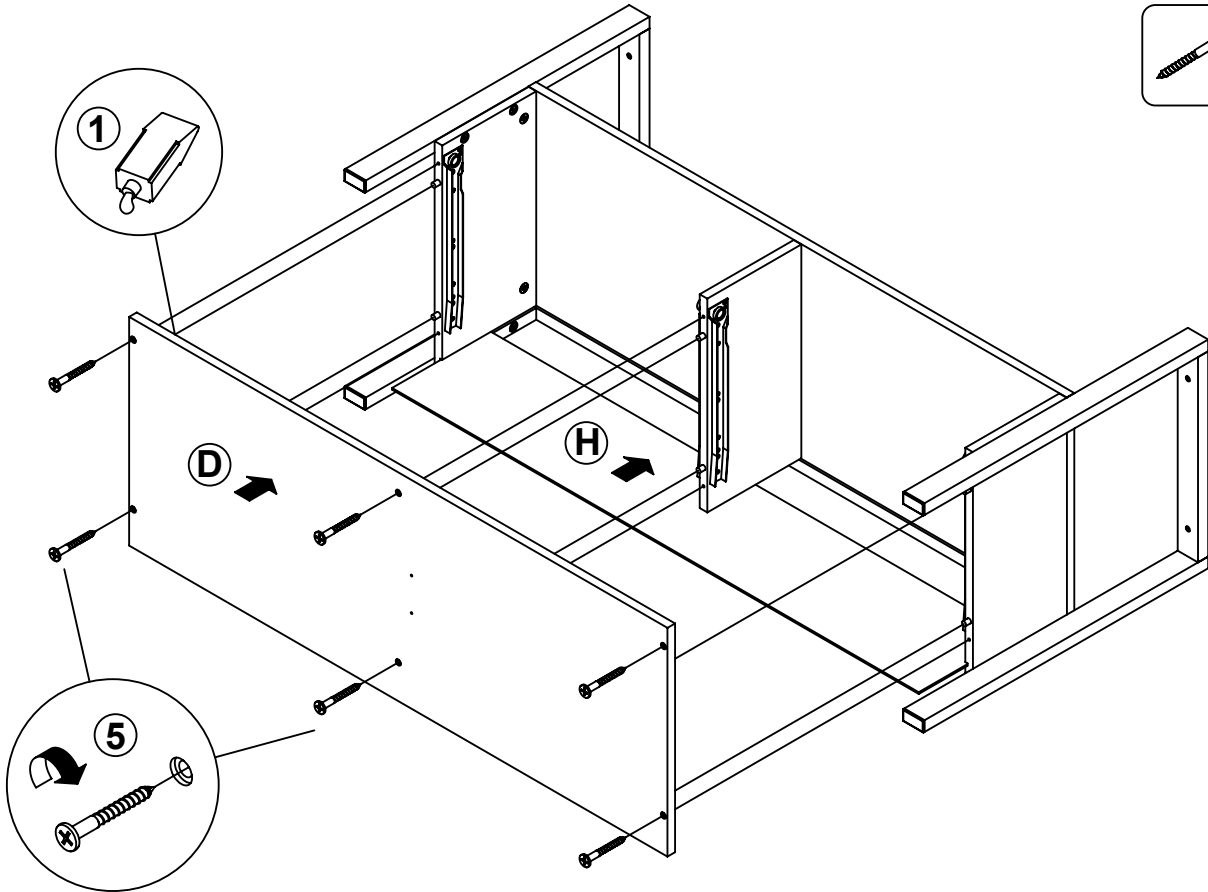
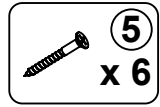

**STEP 6**

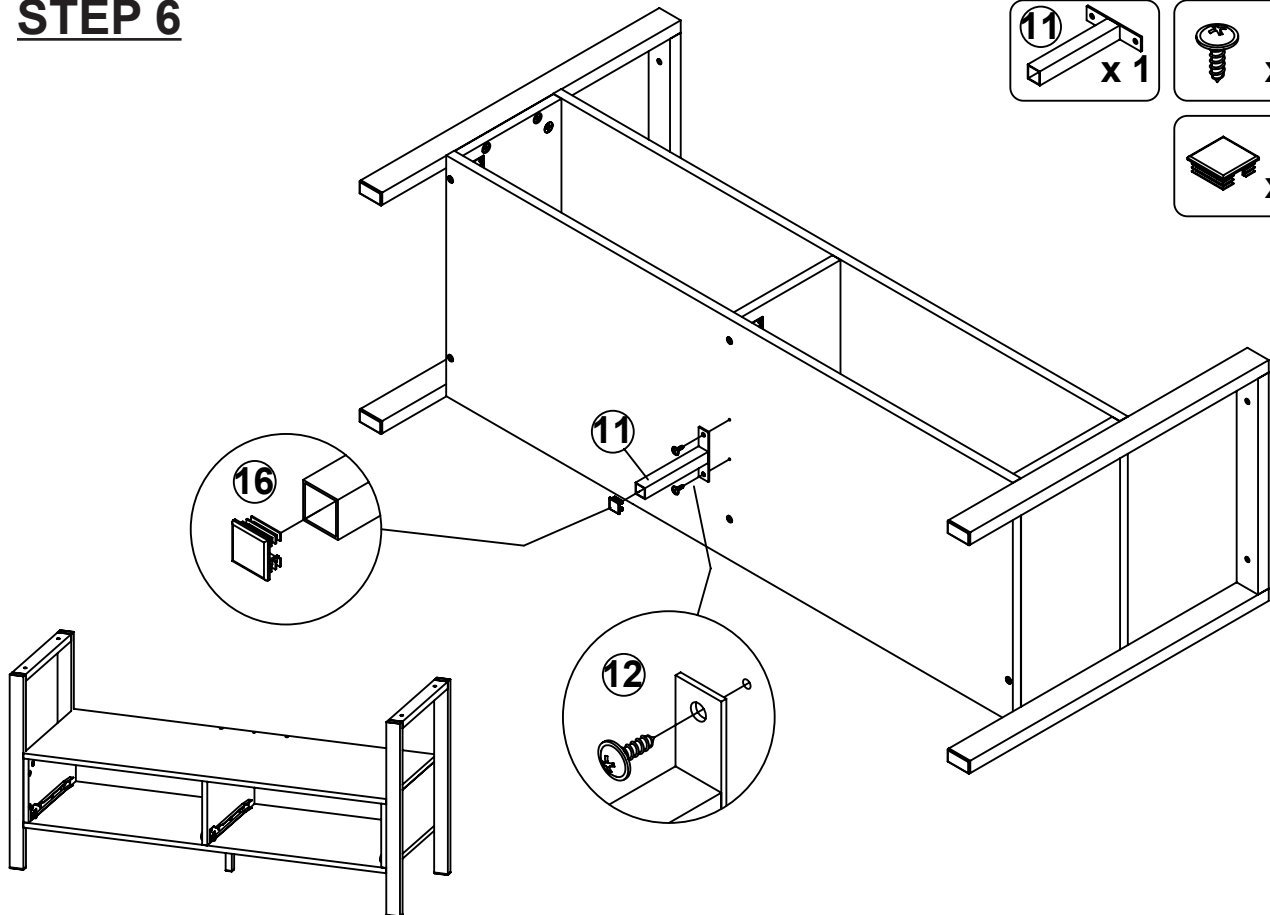
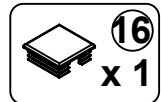
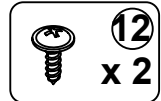
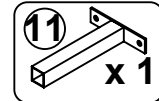

ITEM: 721881

**STEP 7**

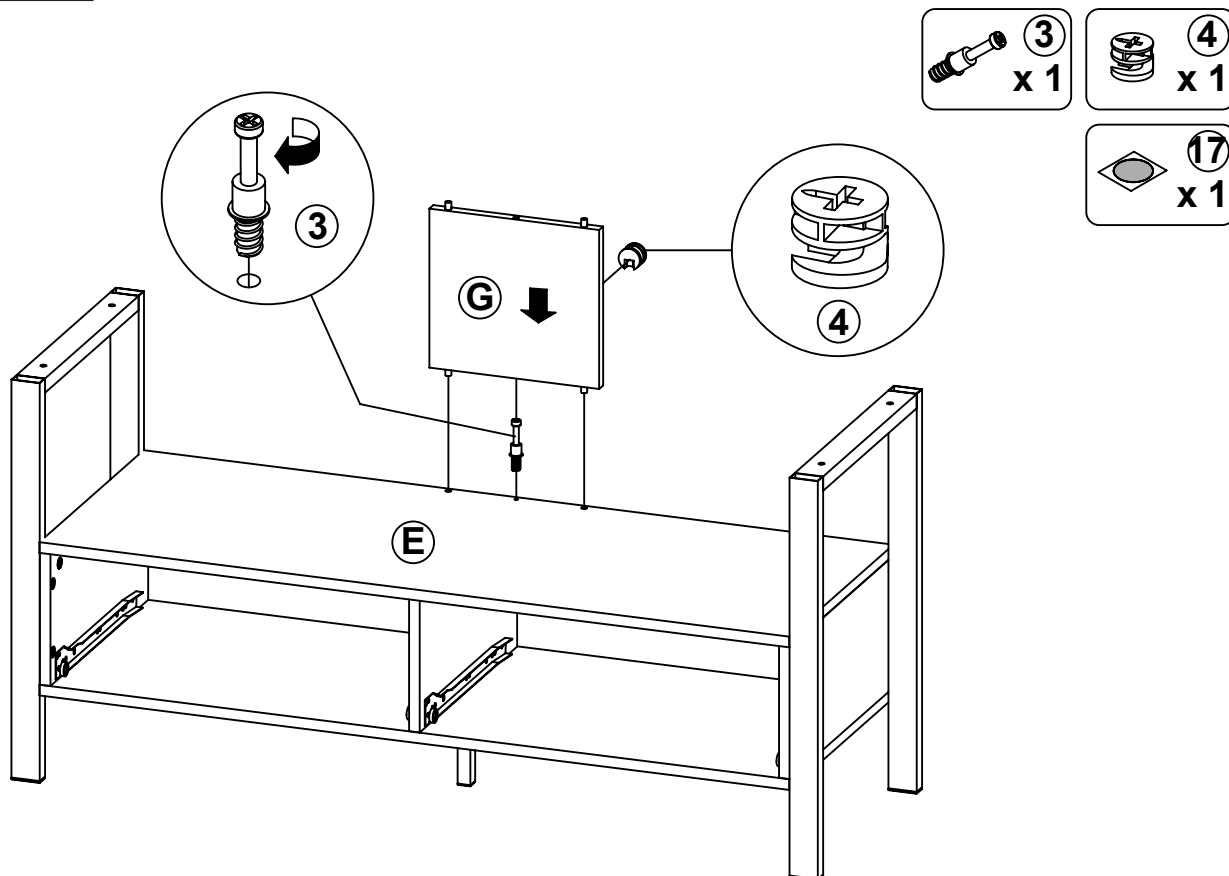

**STEP 8**

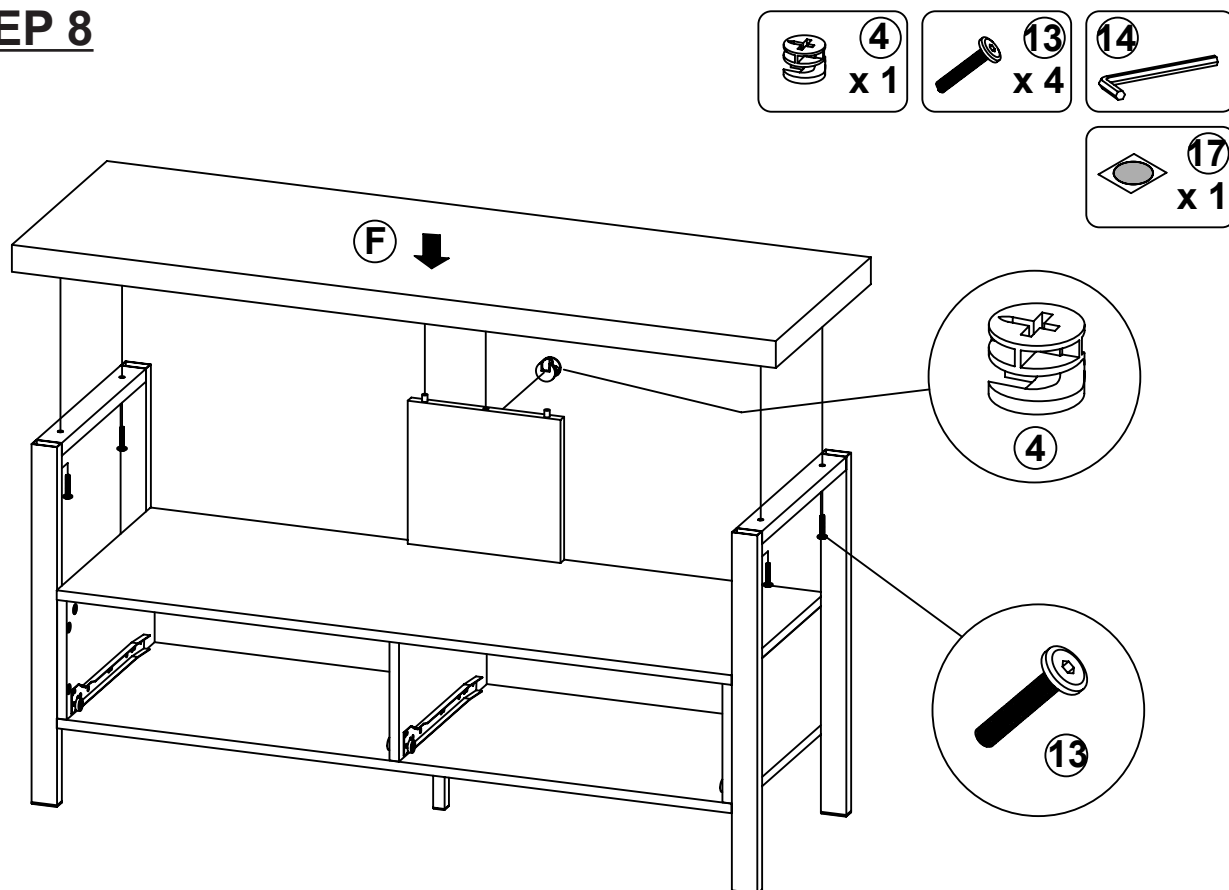



ITEM: 721881

**STEP 9-1**

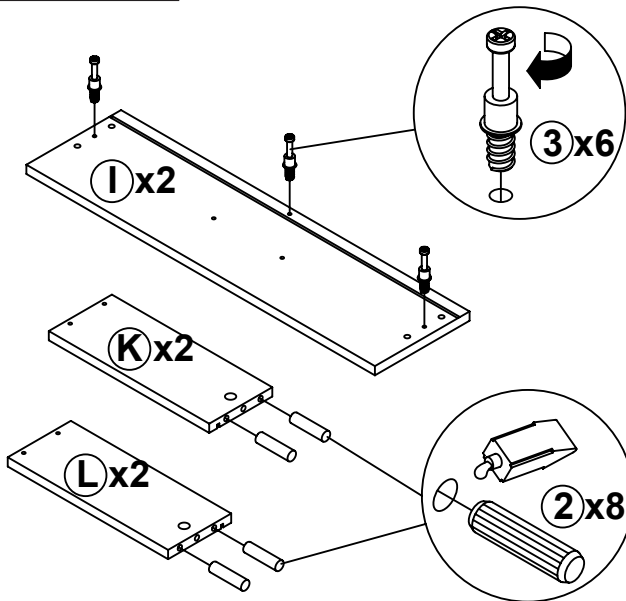

**STEP 9-2**

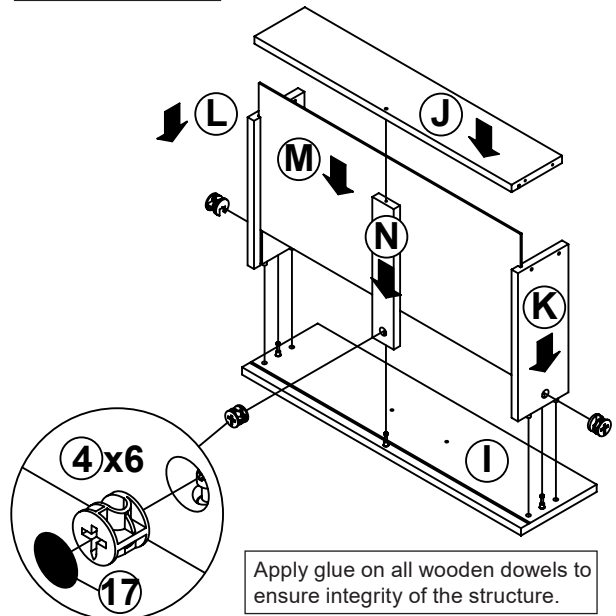

**STEP 9-3**

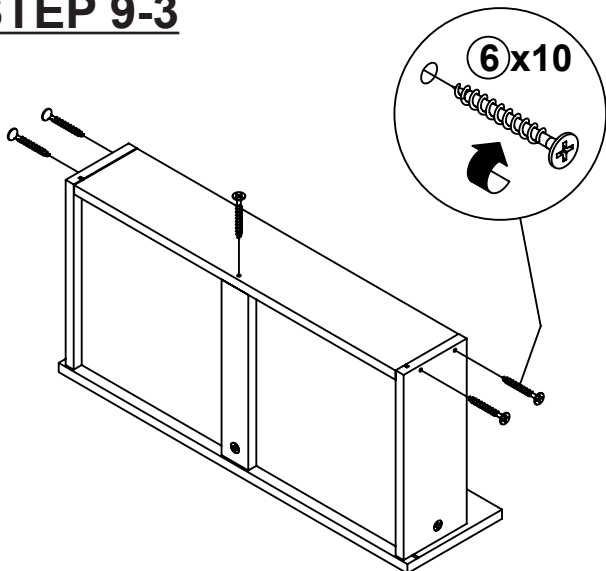

**STEP 9-4**

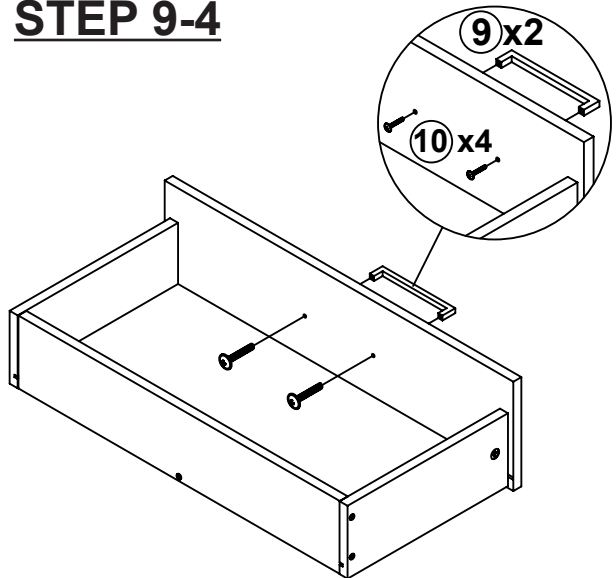

**STEP 9-5**

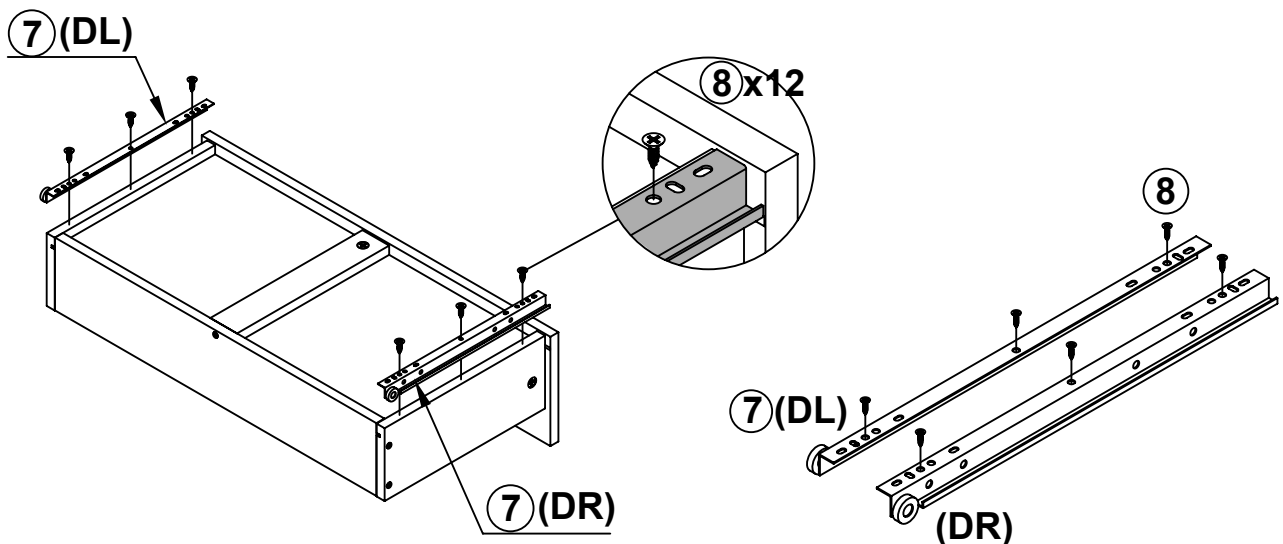

ITEM: 721881

**STEP 10**

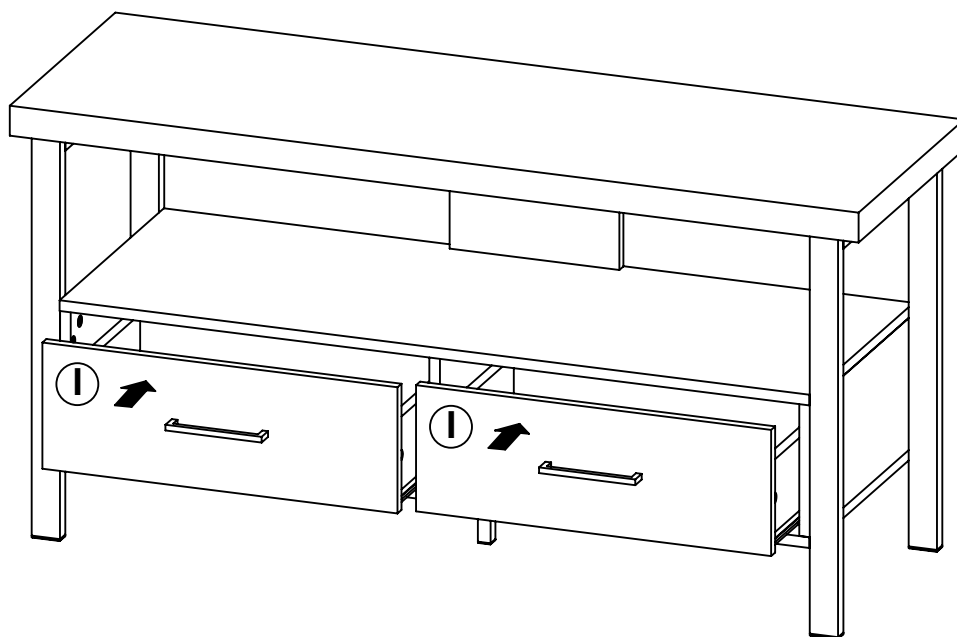

**STEP 11**

**COMPLETE**

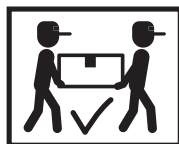
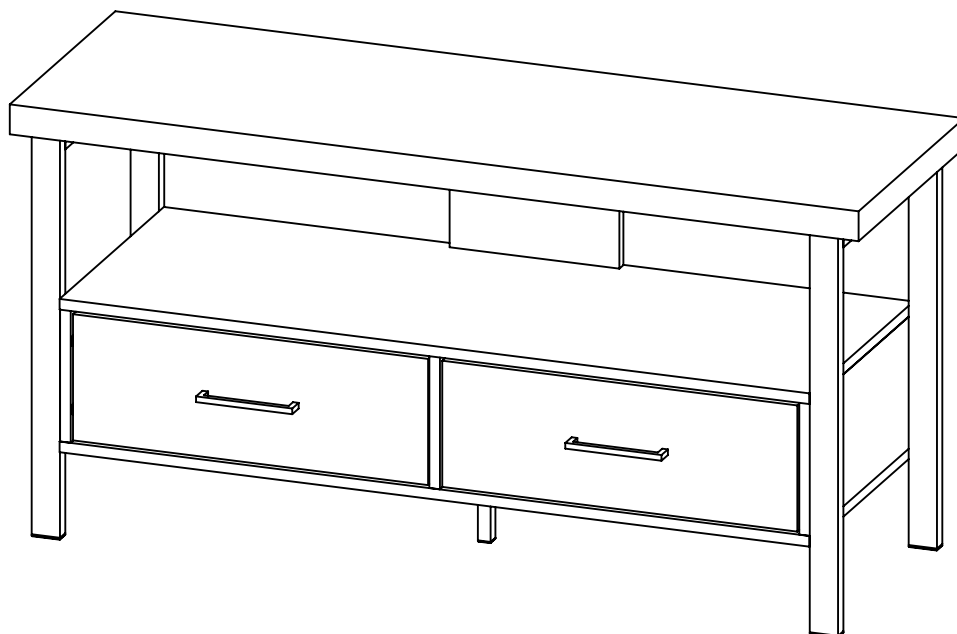

ITEM: 721881

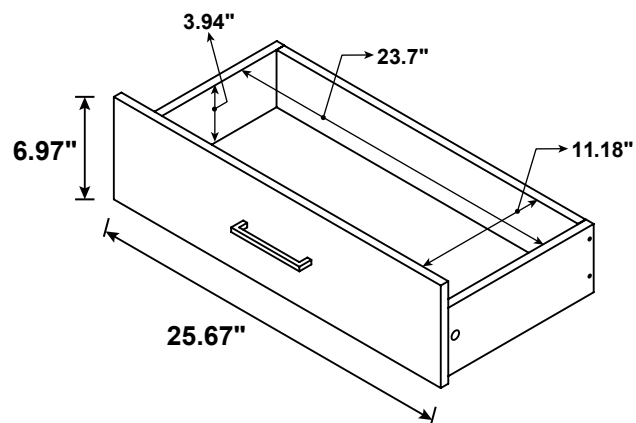
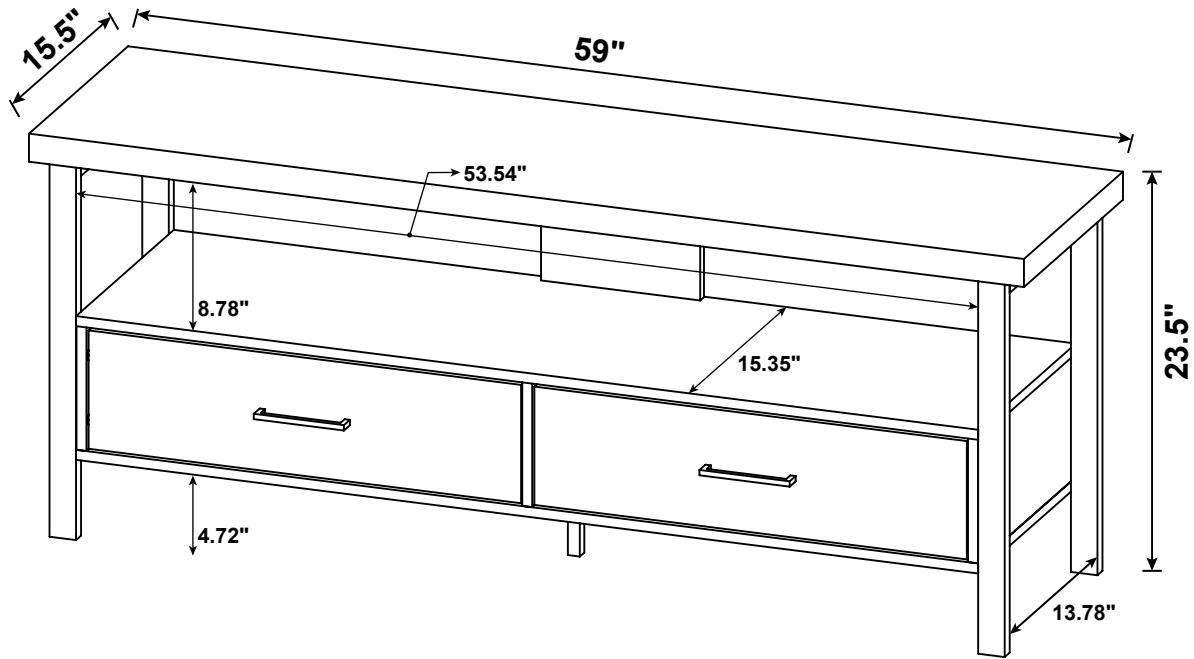

Note : Dimension tolerance  $\pm 5\%$