



ASSEMBLY INSTRUCTIONS
COASTER FINE FURNITURE



Fine Furniture for every stage of life

192951 (B1&B2)
Dining Table

ITEM: 192951 (B1&B2)

ASSEMBLY INSTRUCTIONS



ASSEMBLY TIPS:

1. Remove hardware from box and sort by size.
2. Please check to see that all hardware and parts are present prior to start of assembly.
3. Please follow attached instruction in the same sequence as numbered to assure fast and easy assembly.



WARNING !



1. Don't attempt to repair or modify parts that are broken or defective. Please contact the store immediately.
2. This product is for home use only and not intended for commercial establishment.



ASSEMBLY TIME



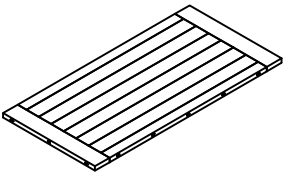
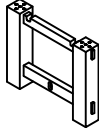
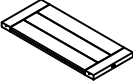



20 MINUTES

PARTS IDENTIFICATION

A	TOP		1PC	C	LEG FRAME		2PCS
B	LEAF		2PCS	D	CROSS BAR		1PC

HARDWARE IDENTIFICATION

Z-B2 (BOX 2) - HARDWARE PACK IS LOCATED IN 192951 (B2)

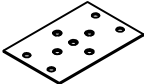
1	LONG BOLT (M8 x 70mm - ATQ)		4PCS	5	LOCK WASHER (M8 - BLK)		20PCS
2	SHORT BOLT (M8 x 25mm - BLK)		16PCS	6	FLAT WASHER (M8 - BLK)		20PCS
3	FLAT HEAD SCREW (M6 x 25mm - BLK)		16PCS	7	WRENCH (M12&17 - BLK)		1PC
4	METAL PLATE (146 x 220mm - BLK)		4PCS				

NOTE:

Philips head screw driver is required in the assembly process; however, manufacturer does not provide this item.

ITEM: 192951 (B1&B2)

ASSEMBLY INSTRUCTIONS

192951 (B2) - BOX 2

STEP 1

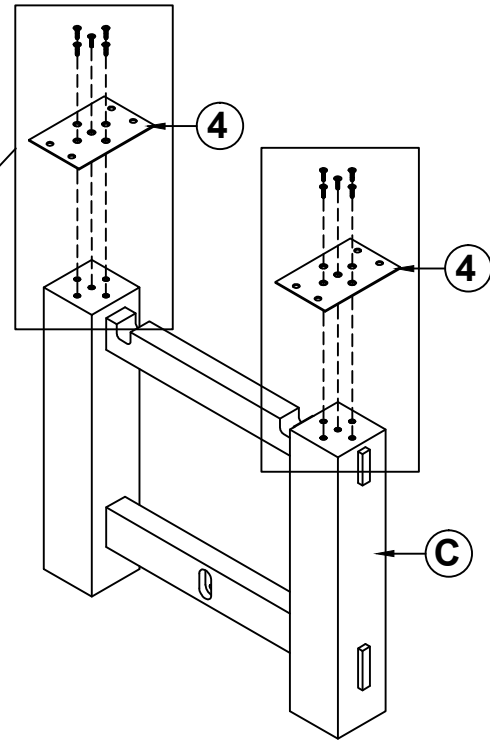
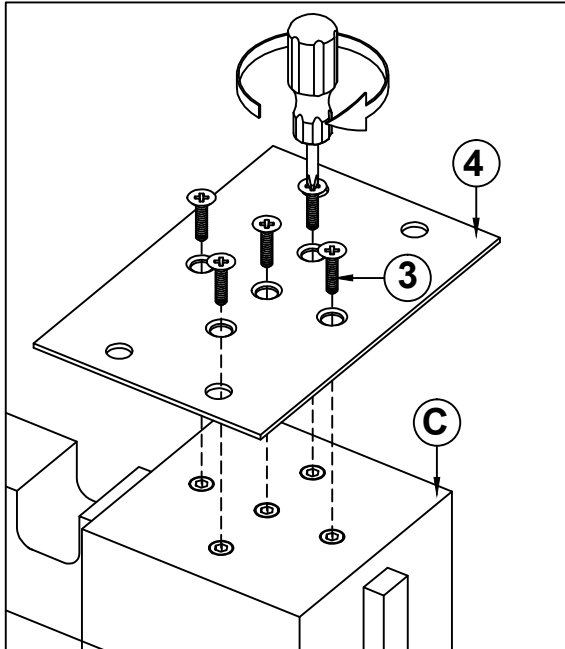

192951 (B1&B2) - BOX 1 TO BOX 2

STEP 2

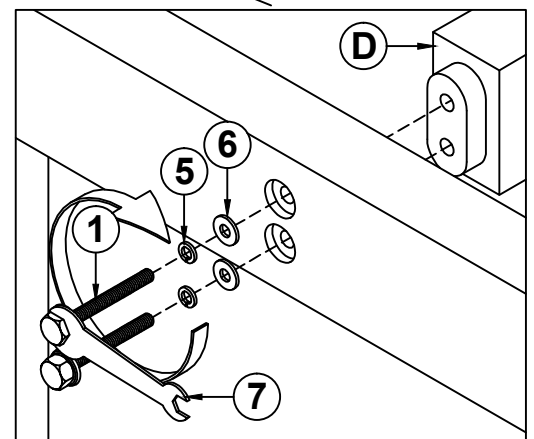
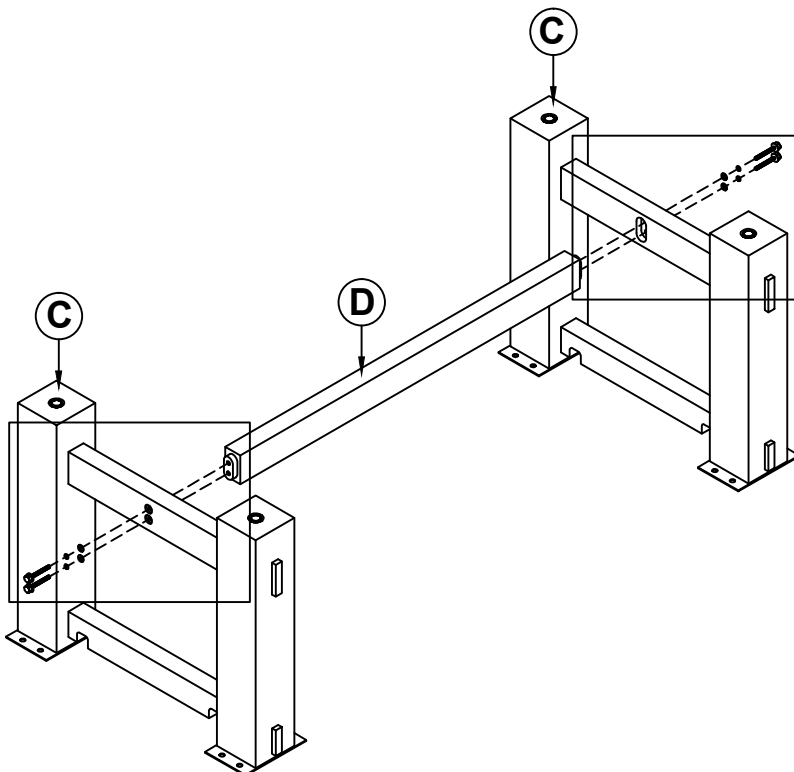

ITEM: 192951 (B1&B2)

ASSEMBLY INSTRUCTIONS

STEP 3

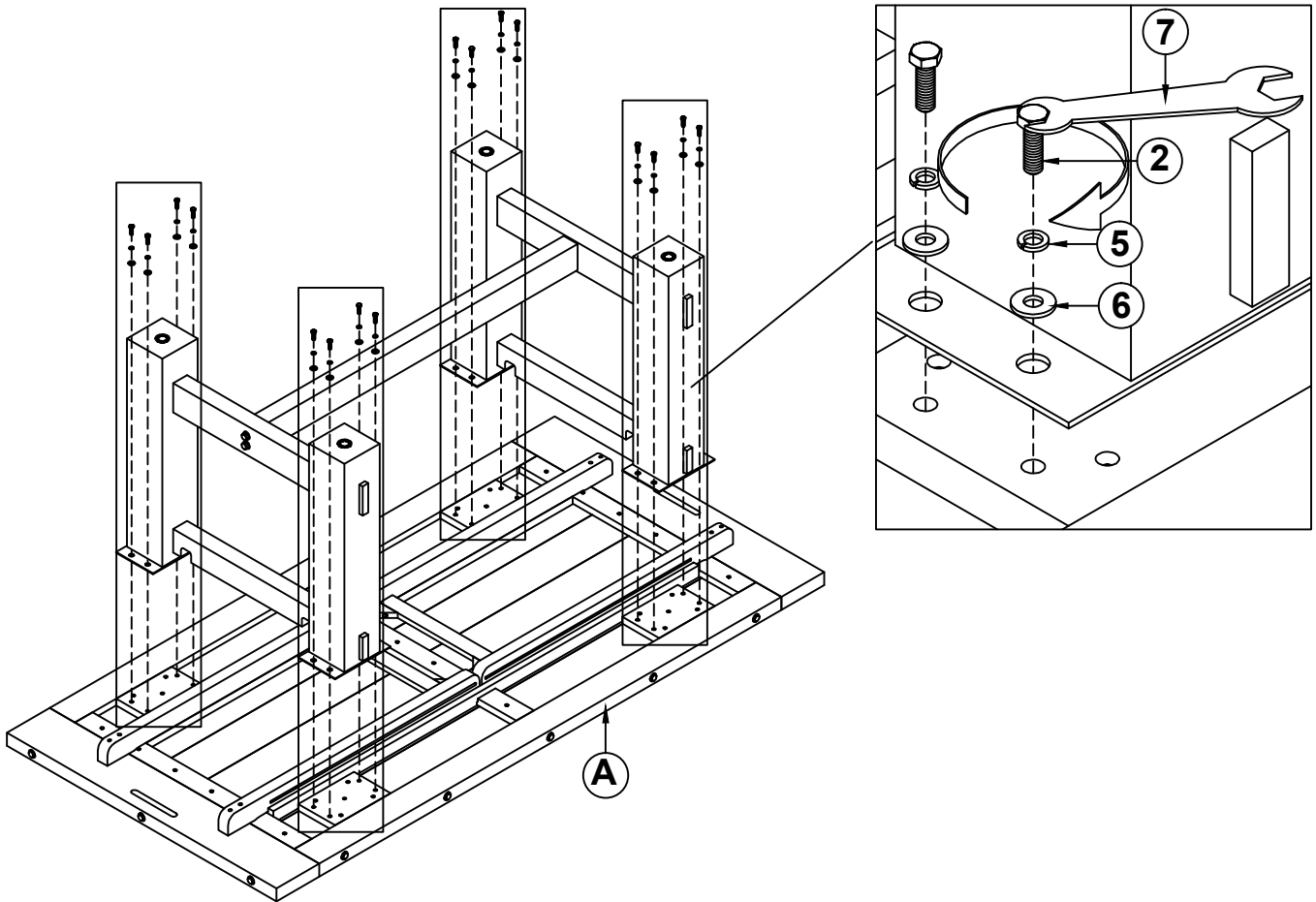

STEP 4

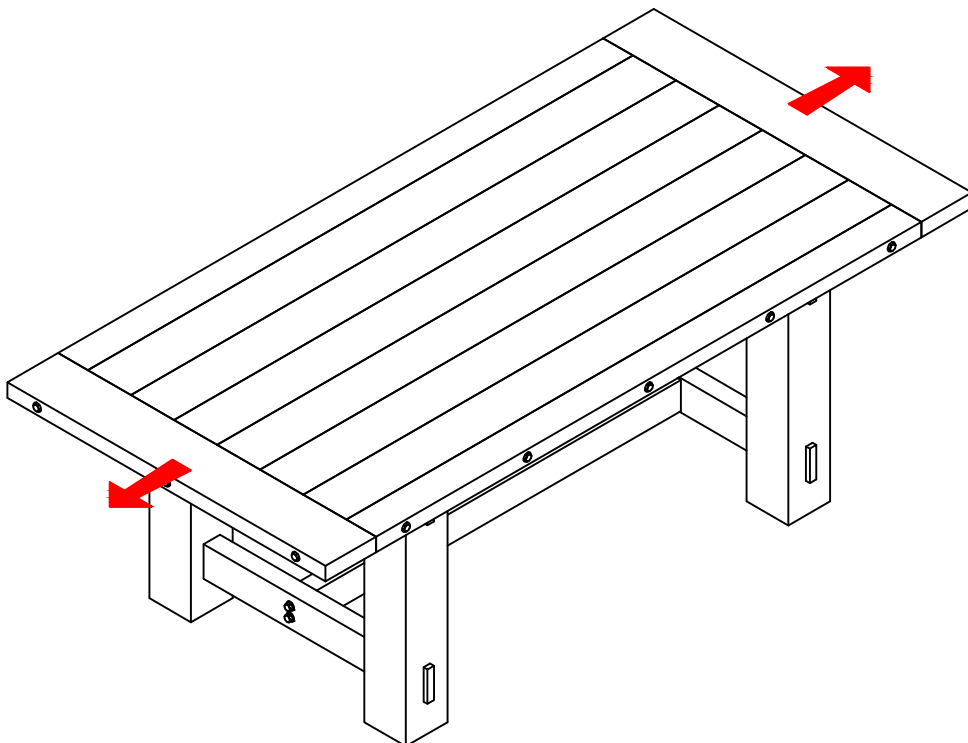

ITEM: 192951 (B1&B2)

ASSEMBLY INSTRUCTIONS

STEP 5

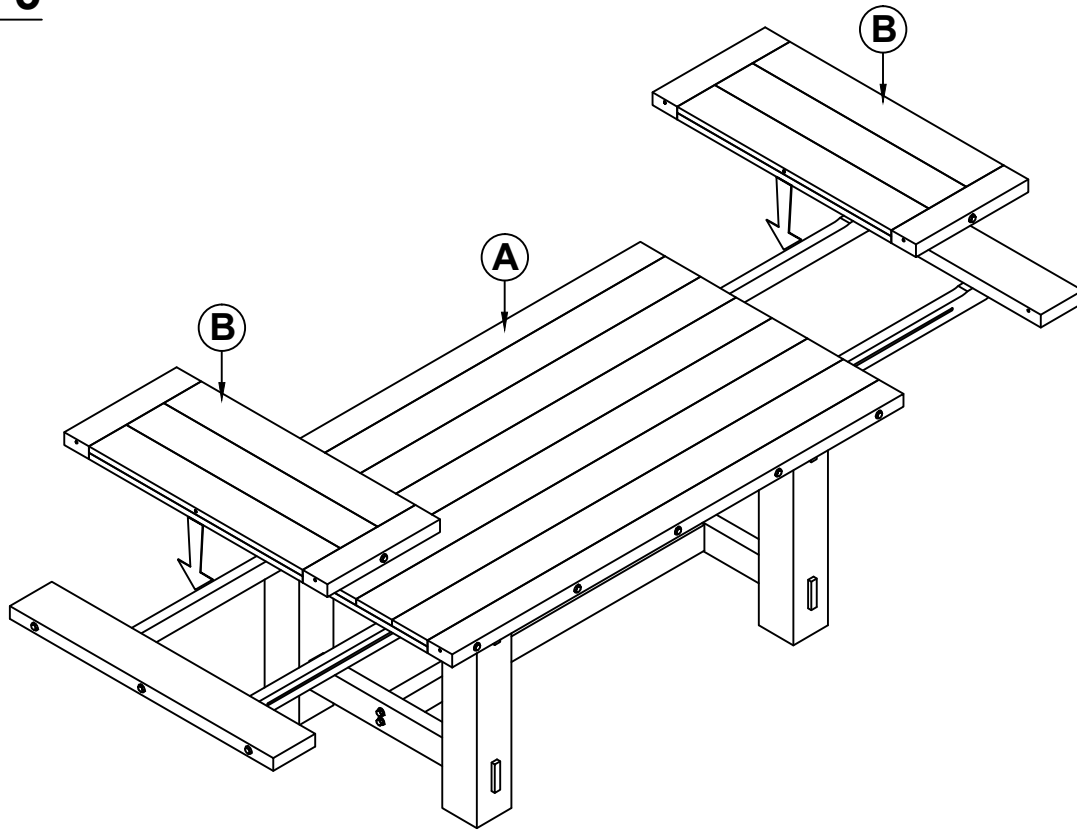

STEP 6

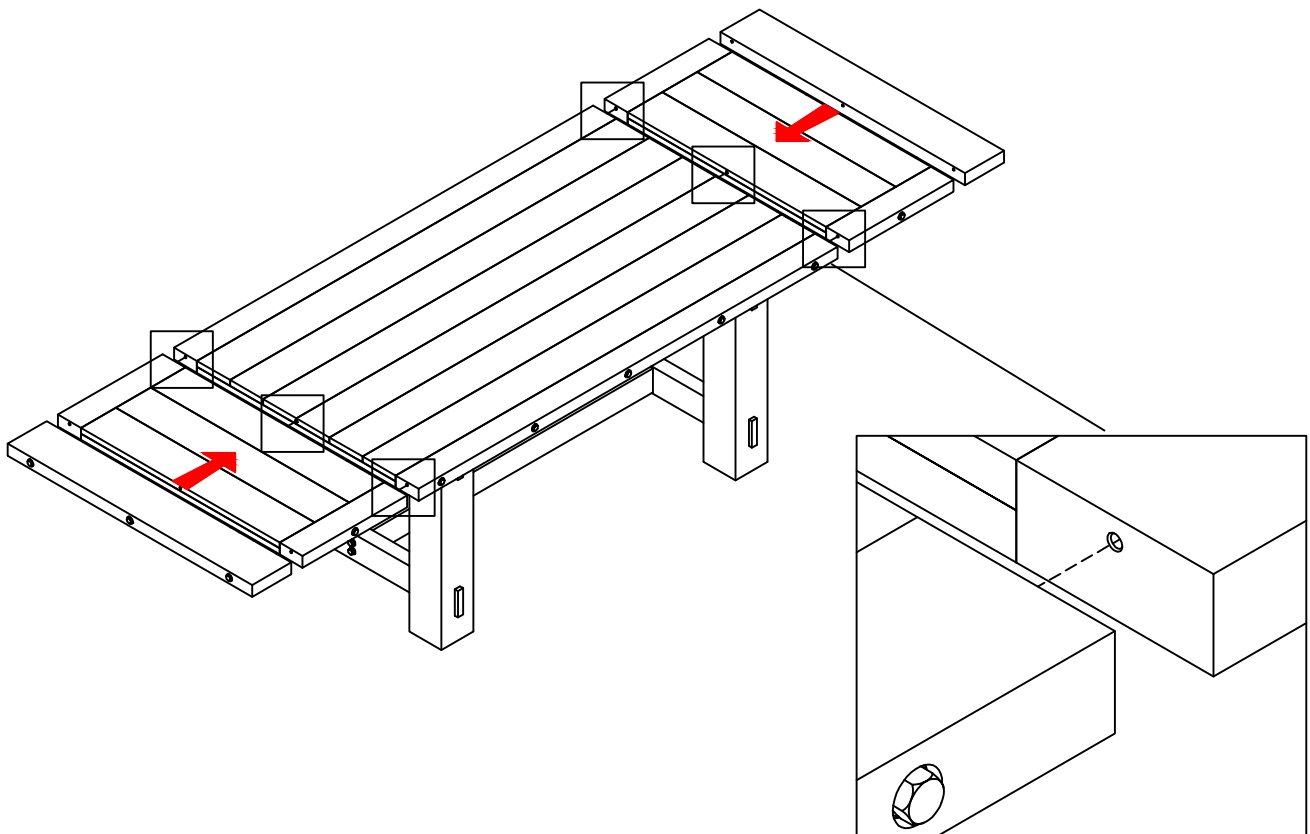

ITEM: 192951 (B1&B2)

ASSEMBLY INSTRUCTIONS

STEP 7

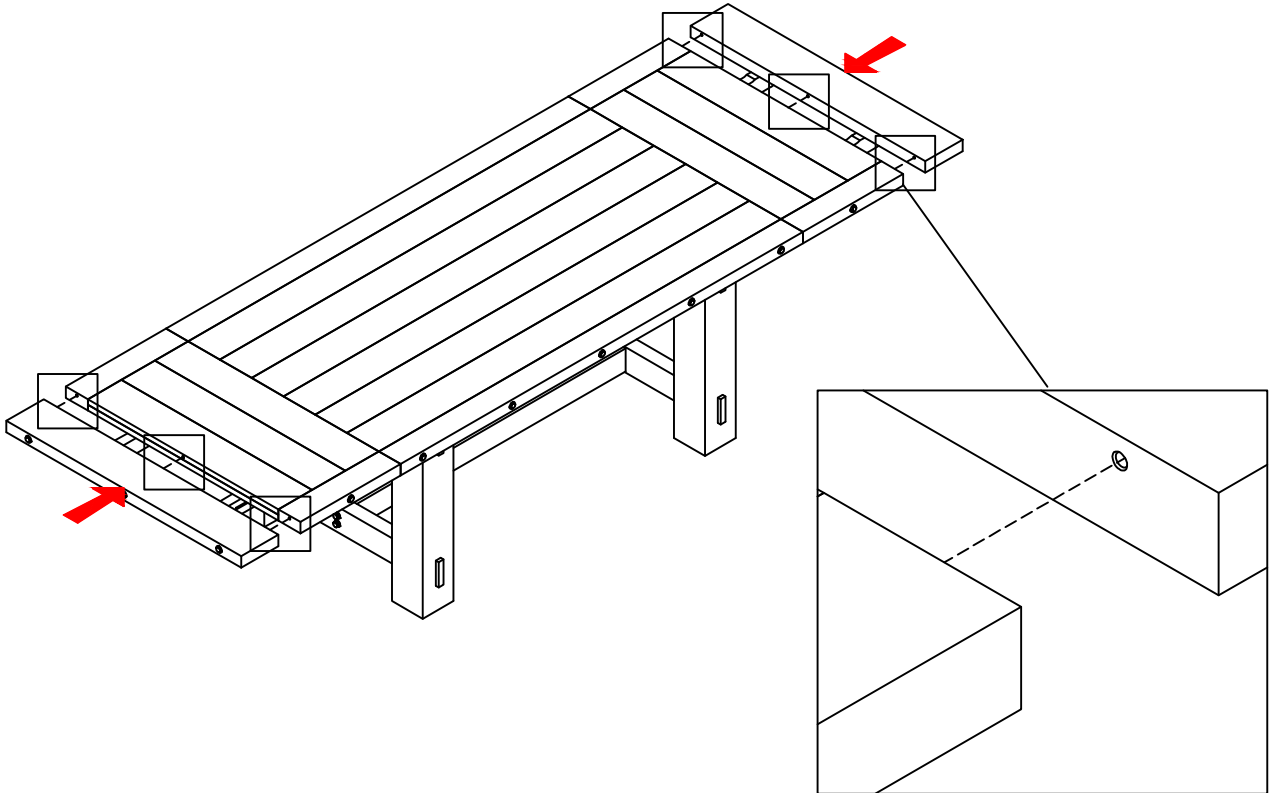

STEP 8

COMPLETE

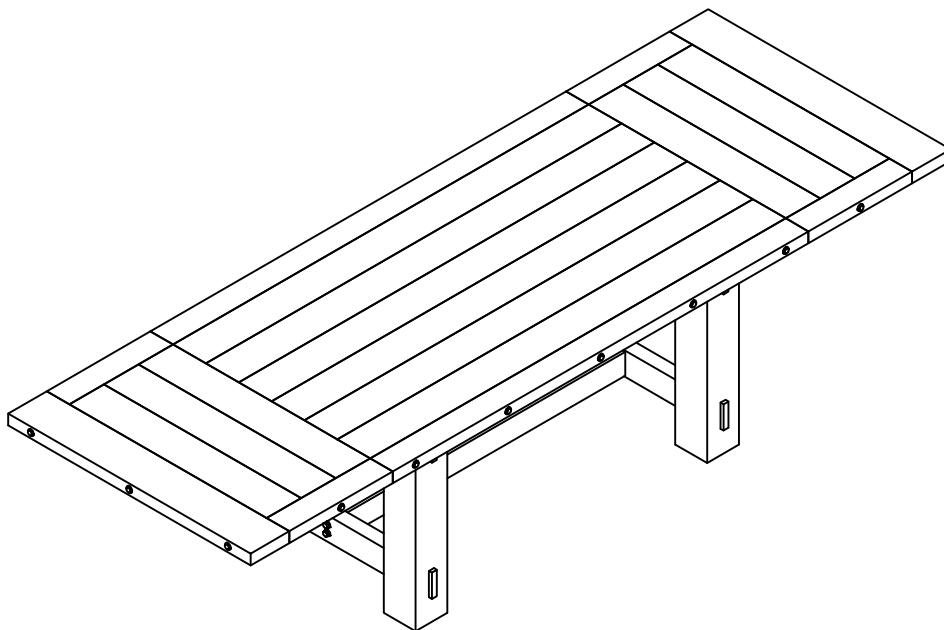

ITEM: 192951 (B1&B2)

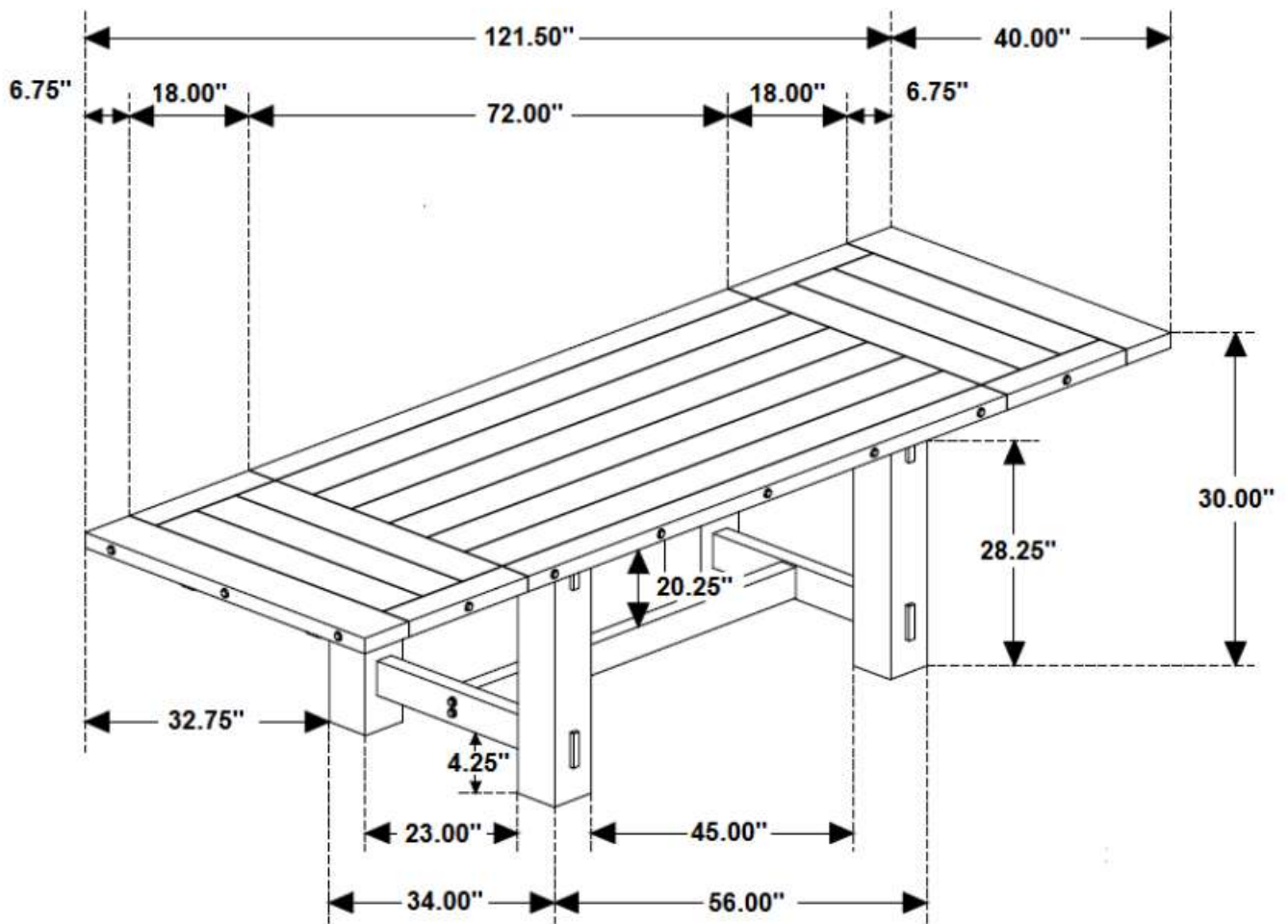

Note: Dimension tolerance $\pm 5\%$