

ASSEMBLY INSTRUCTIONS
COASTER FINE FURNITURE



Fine Furniture for every stage of life

192956
Bench

ITEM: 192956

ASSEMBLY INSTRUCTIONS

ASSEMBLY TIPS:

1. Remove hardware from box and sort by size.
2. Please check to see that all hardware and parts are present prior to start of assembly.
3. Please follow attached instruction in the same sequence as numbered to assure fast and easy assembly.



WARNING !

1. Don't attempt to repair or modify parts that are broken or defective. Please contact the store immediately.
2. This product is for home use only and not intended for commercial establishment.





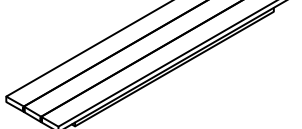
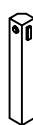
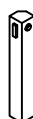

ASSEMBLY TIME

20 MINUTES

PARTS IDENTIFICATION

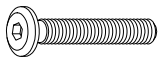
A	SEAT		1PC
B	LEG (WITH "B" LABEL")		2PCS
C	LEG (WITH "C" LABEL")		2PCS

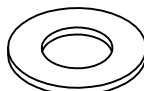
HARDWARE IDENTIFICATION

1	BOLT (M8 x 60mm - BLK)		8PCS
2	LOCK WASHER (M8 - BLK)		8PCS
3	FLAT WASHER (M8 - BLK)		8PCS
4	ALLEN WRENCH (M5 - BLK)		1PC

ITEM: **192956**
ASSEMBLY INSTRUCTIONS

STEP 1

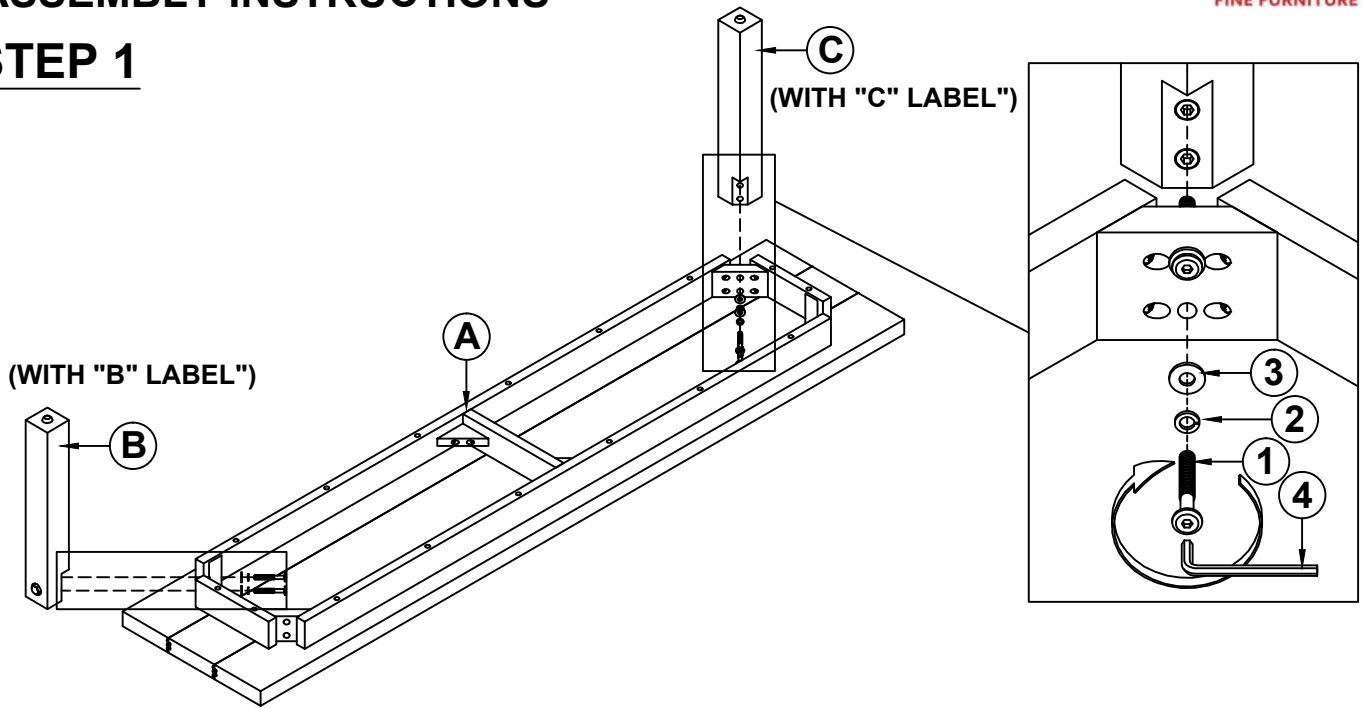

STEP 2

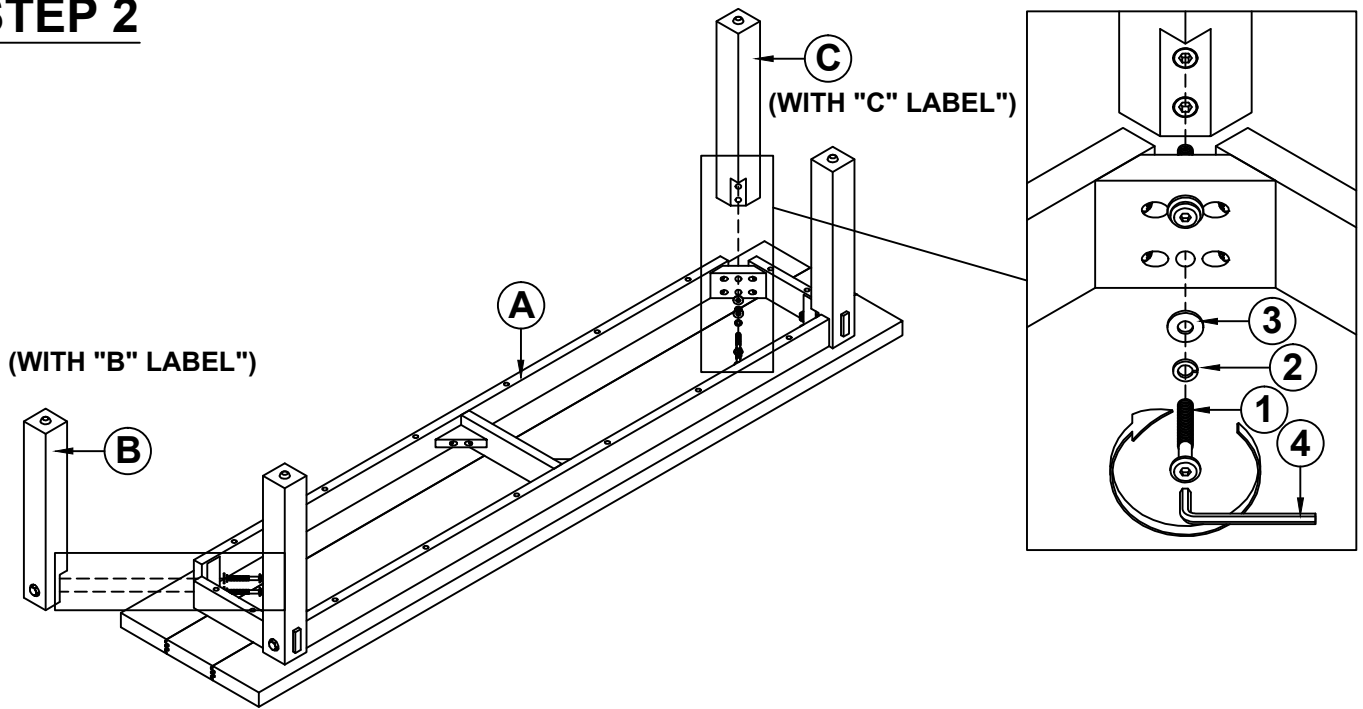

STEP 3
COMPLETE

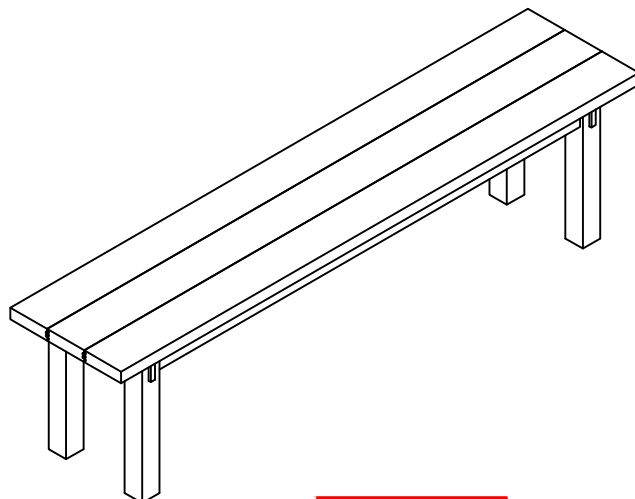

ITEM: 192956

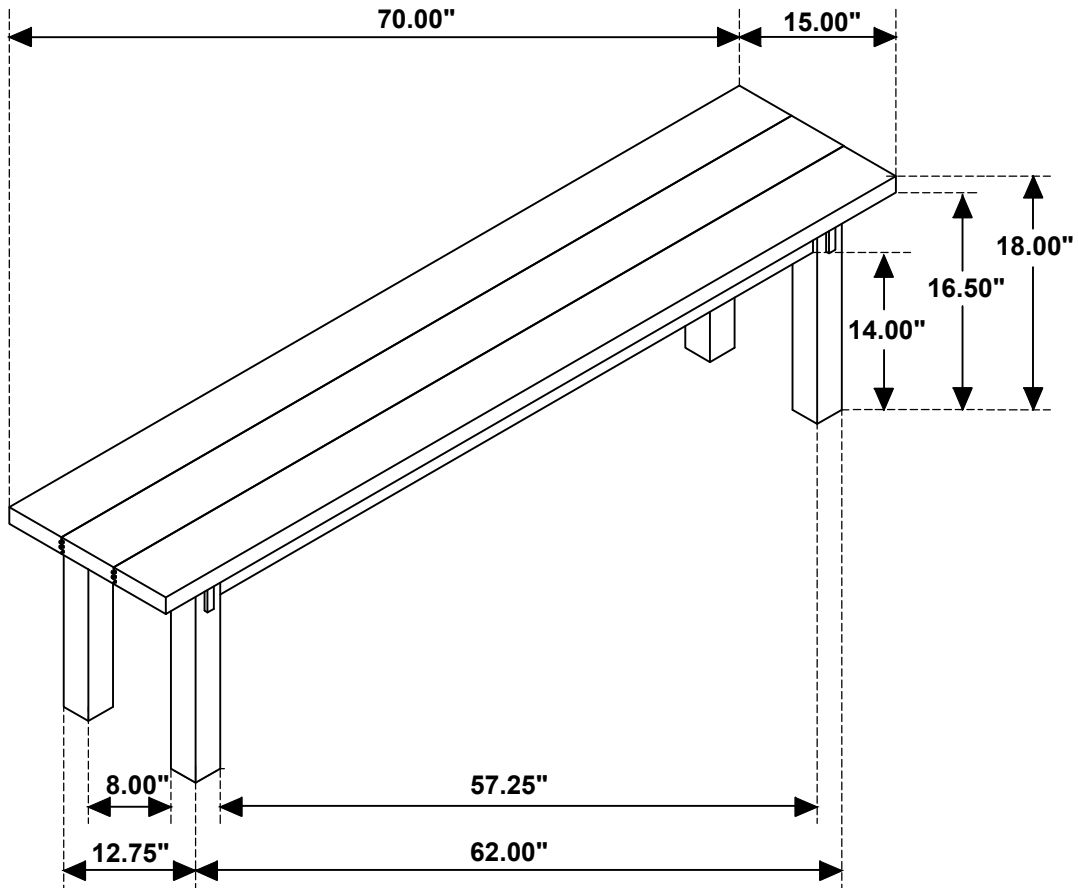

Note: Dimension tolerance $\pm 5\%$