

ASSEMBLY INSTRUCTIONS
COASTER FINE FURNITURE



Fine Furniture for every stage of life

721891
TV CONSOLE

ITEM: 721891



ASSEMBLY INSTRUCTIONS

ASSEMBLY TIPS:

1. Remove hardware from box and sort by size.
2. Please check to see that all hardware and parts are present prior to start of assembly.
3. Please follow attached instructions in the same sequence as numbered to assure fast & easy assembly.



WARNING!

1. Don't attempt to repair or modify parts that are broken or defective. Please contact the store immediately.
2. This product is for home use only and not intended for commercial establishments.



ASSEMBLY TIME

60 MINUTES

MAX TV SIZE : 75"

PARTS IDENTIFICATION











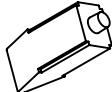

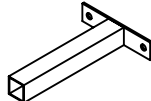
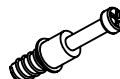
A	LEFT SIDE PANEL		1 PC	H	LOWER BACK PANEL		1 PC
B	RIGHT SIDE PANEL		1 PC	I	DRAWER FRONT PANEL		3 PCS
C	MIDDLE DIVIDER PANEL		2 PCS	J	DRAWER BACK PANEL		3 PCS
D	BOTTOM PANEL		1 PC	K	LEFT DRAWER SIDE PANEL		3 PCS
E	CROSS PANEL		1 PC	L	RIGHT DRAWER SIDE PANEL		3 PCS
F	TOP		1 PC	M	DRAWER BOTTOM PANEL		3 PCS
G	UPPER BACK PANEL		1 PC	N	LEG		2 PCS

NOTE:

Phillips head screw driver is required in the assembly process; however, manufacturer does not provide this item.

ITEM: 721891

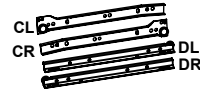
HARDWARE IDENTIFICATION

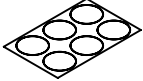
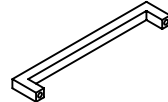
Z							
NO	DESCRIPTION	FIGURE	Q'TY	NO	DESCRIPTION	FIGURE	Q'TY
1	GLUE 40g		1 PC	10	HANDLE BOLT Ø 4x28mm BLK		6 PCS
2	WOODEN DOWEL Ø 8x30mm		32 PCS	11	SQUARE FOOT		2 PCS
3	CAM BOLT Ø 7x35.5mm SR		16 PCS	12	SCREW Ø 4x17mm RBW		4 PCS
4	CAM LOCK Ø 15x12mm SR		16 PCS	13	LONG BOLT M 6x38mm BLK		12 PCS
5	LONG SCREW Ø 4.5x42mm SR		8 PCS	14	ALLEN WRENCH 4mm SR		1 PC
6	SCREW Ø 4.3x35mm SR		12 PCS	15	FLOOR PROTECTOR 40x20mm		4 PCS
7	GLIDES L = 300mm WHT		3 SET	16	FLOOR PROTECTOR 18x18mm		2 PCS
8	GLIDES SCREW Ø 3x10mm SR		36 PCS	17	STICKER Ø 20mm		4 PCS
9	HANDLE L = 137.5mm		3 PCS				







Z7,Z9,Z11 not included in blister packaging.

NOTE:

Phillips head screw driver is required in the assembly process; however, manufacturer does not provide this item.

ITEM: 721891

STEP 1

- | | | |
|---|---|--|
|  ②
x 8 |  ⑦ x 1
CL
CR |  ⑧
x 6 |
|  ⑬
x 8 |  ⑭ |  ⑮
x 4 |

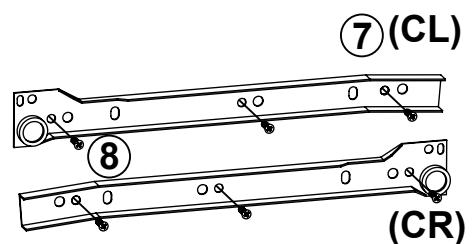
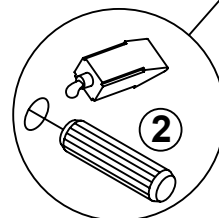
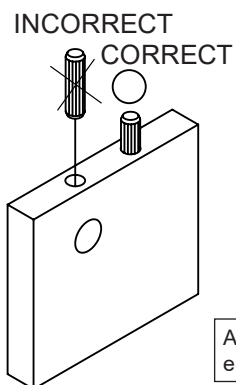
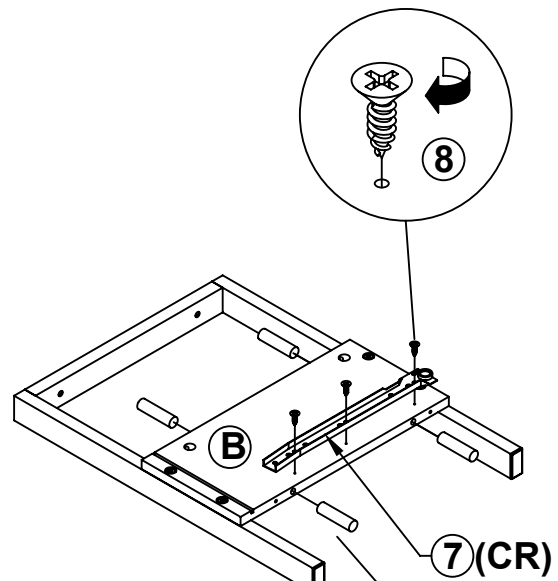
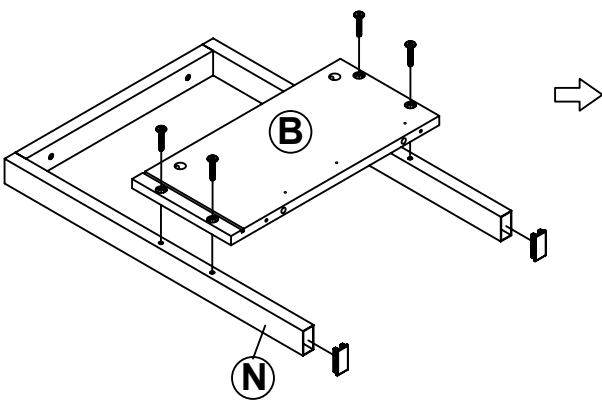
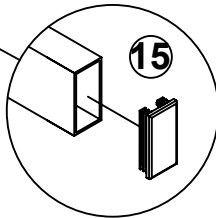
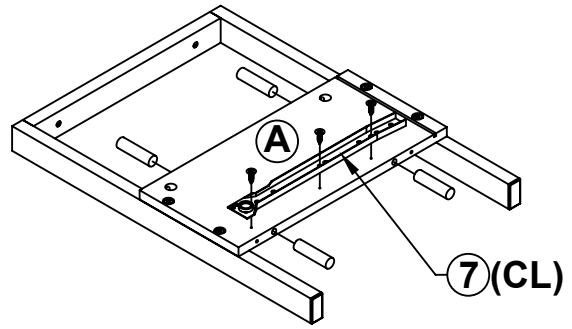
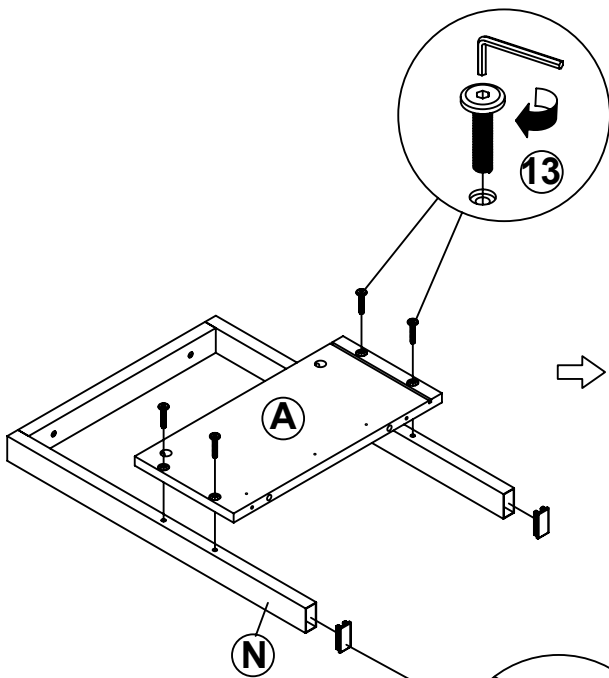

ITEM: 721891

COASTER
FINE FURNITURE

STEP 3

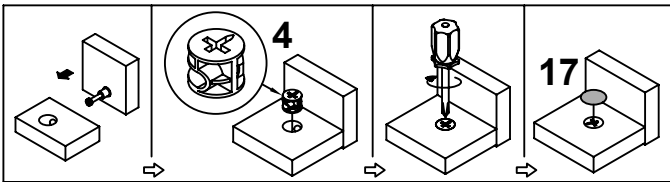
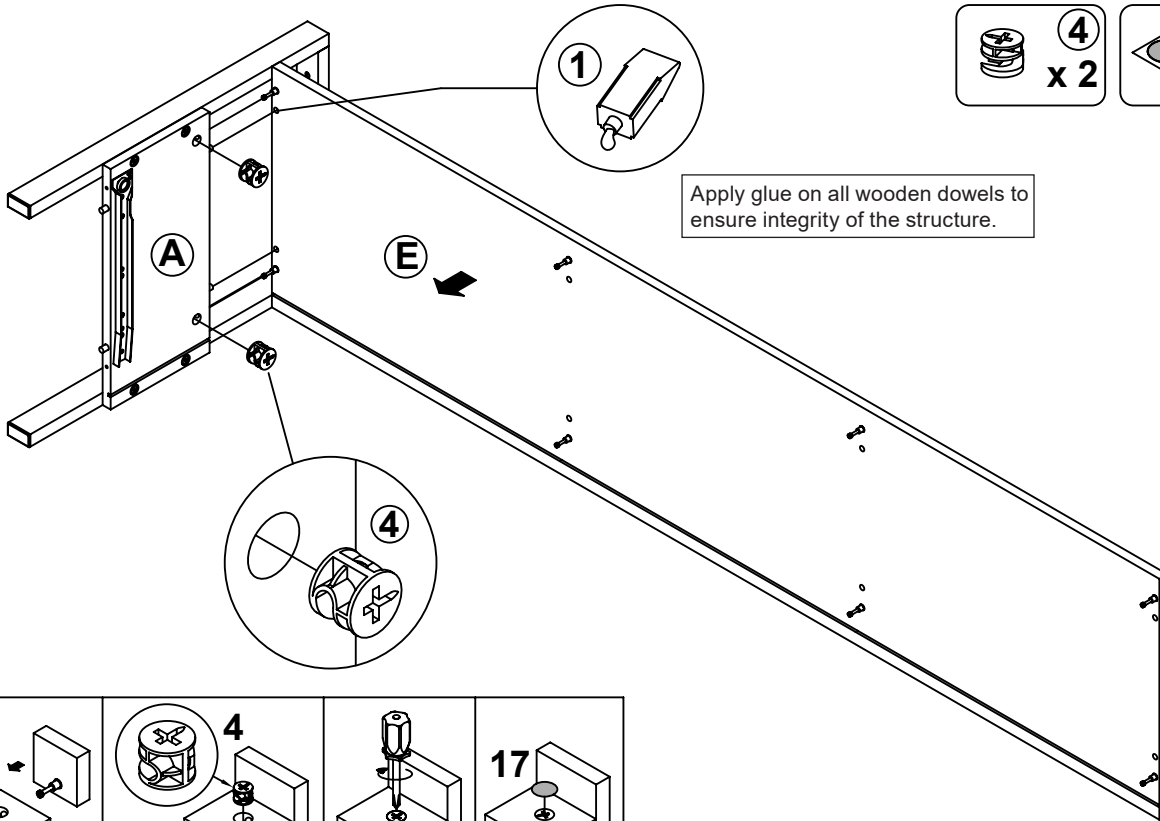
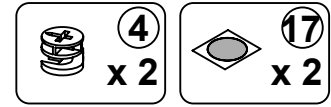

STEP 4

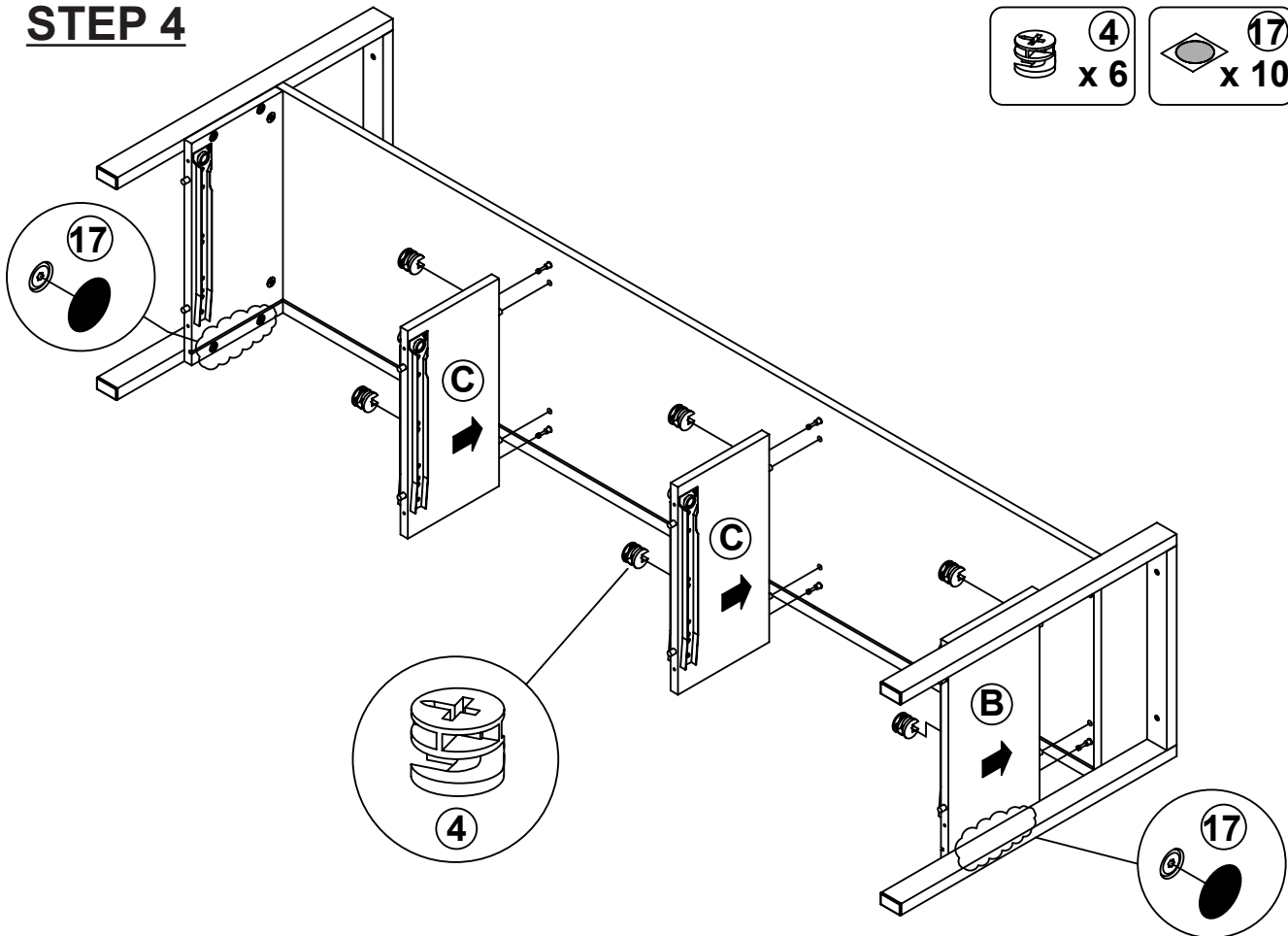
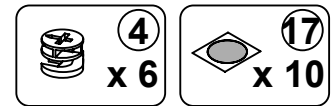

ITEM: 721891

COASTER
FINE FURNITURE

STEP 5

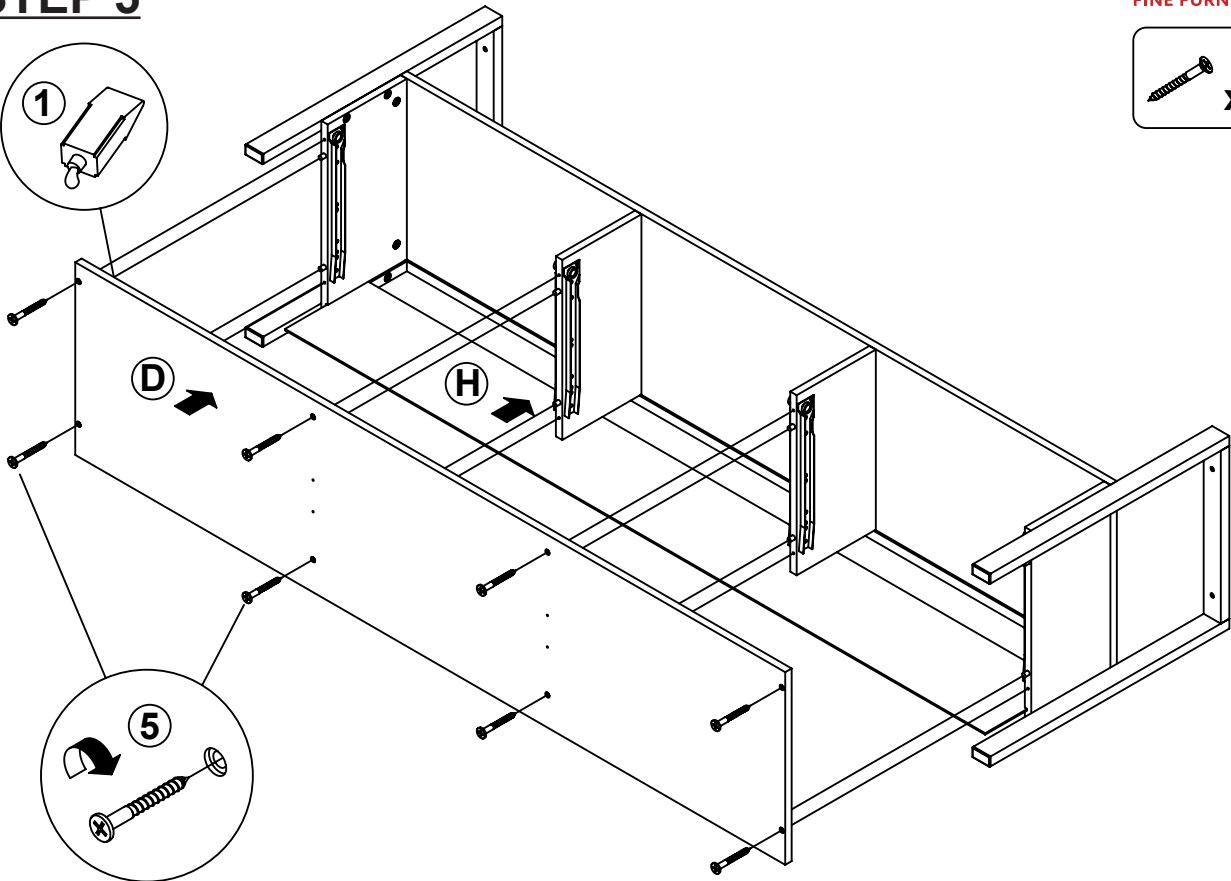
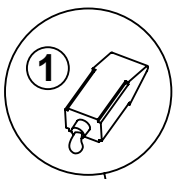
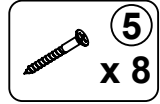

STEP 6

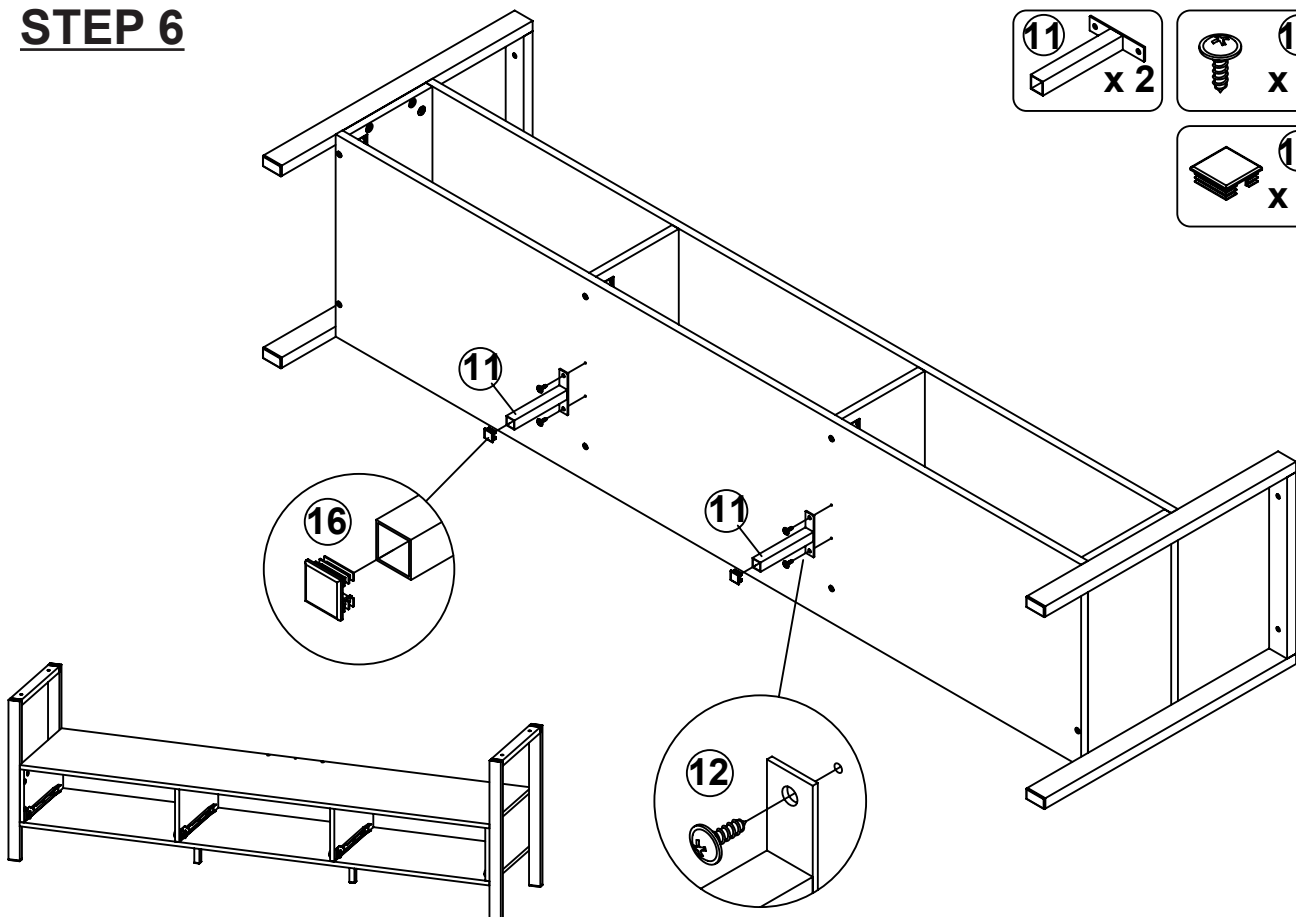
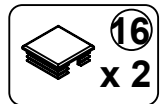
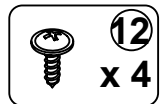
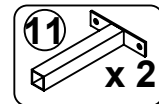

ITEM: 721891

STEP 7

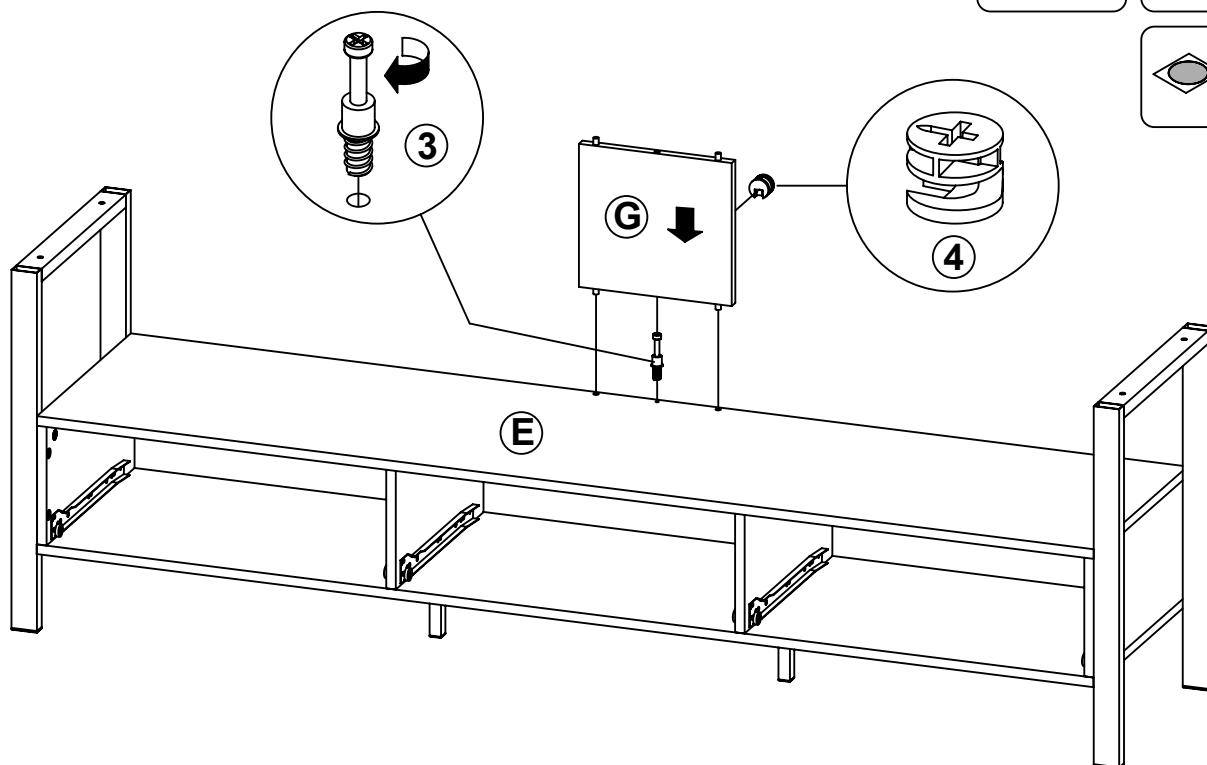
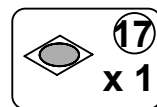

STEP 8

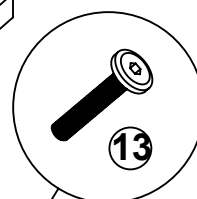
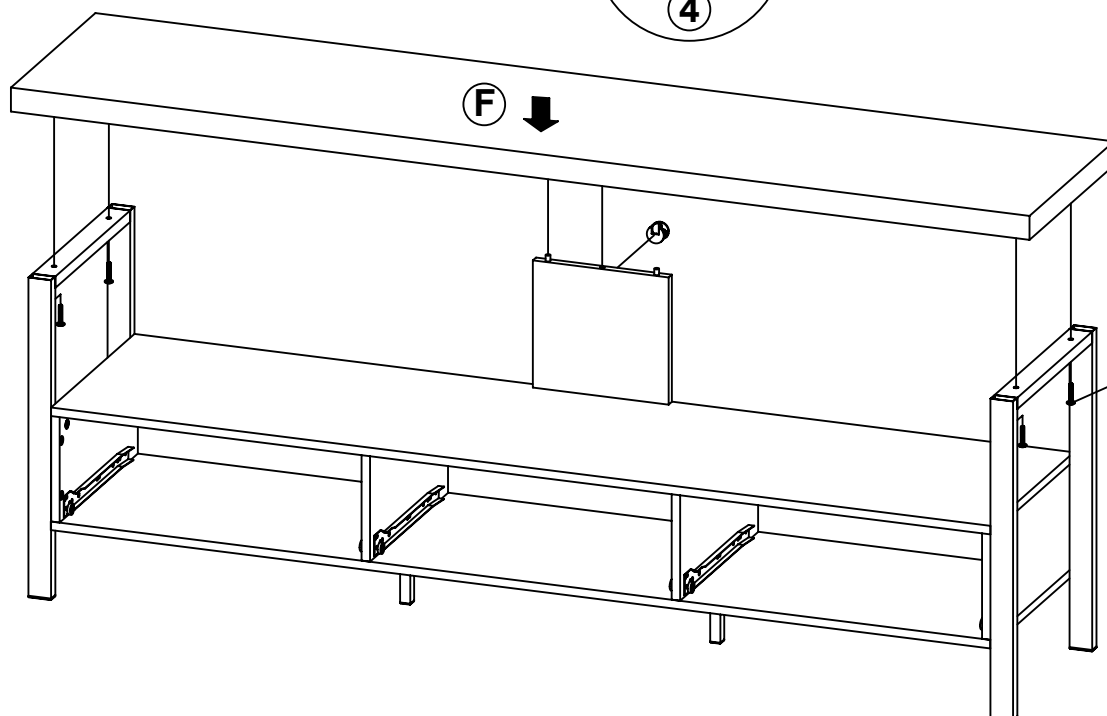
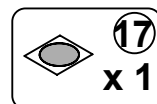
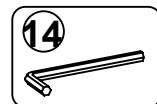
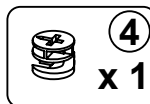
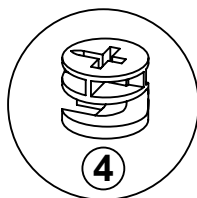

ITEM: 721891

STEP 9-1

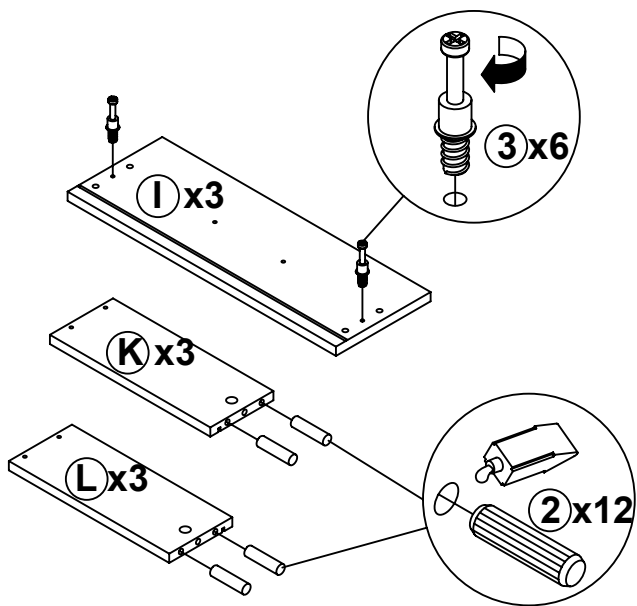

STEP 9-2

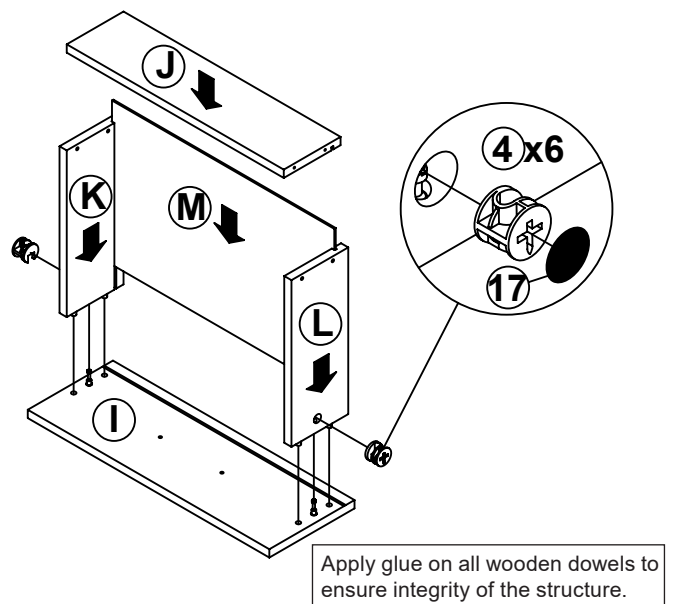

STEP 9-3

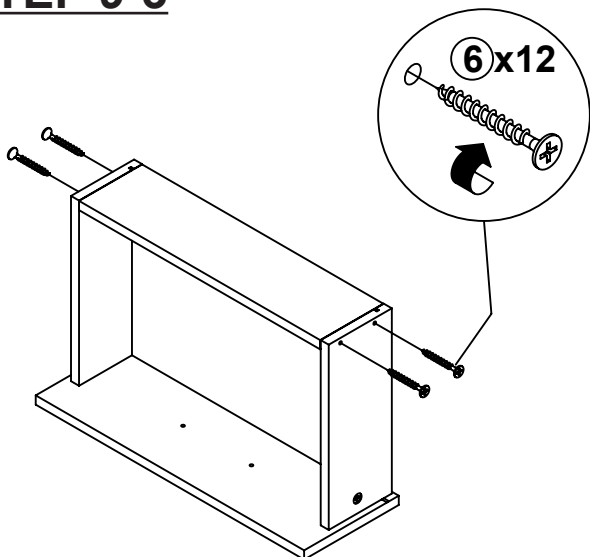

STEP 9-4

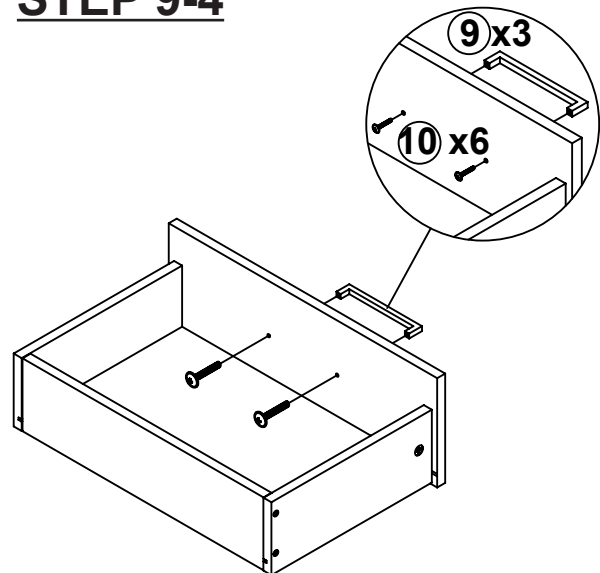

STEP 9-5

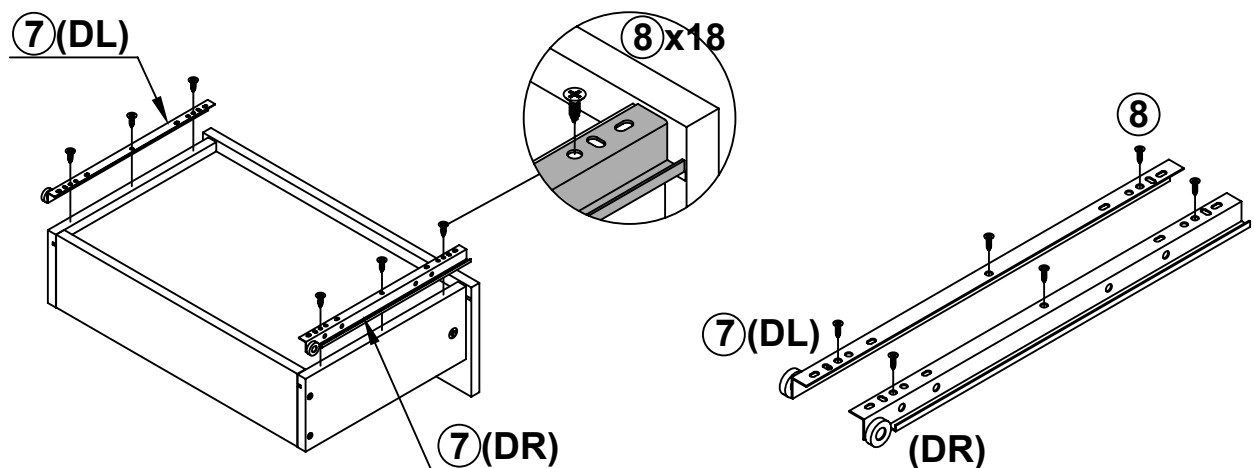

ITEM: 721891

STEP 10

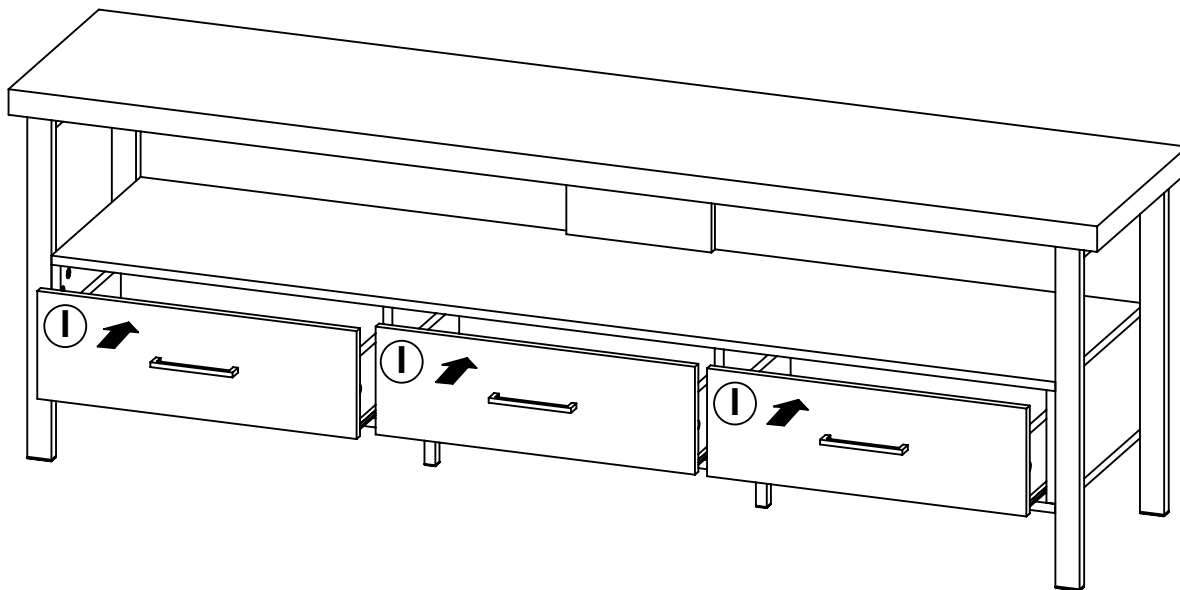

STEP 11
COMPLETE

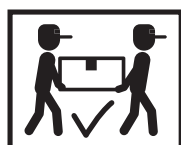
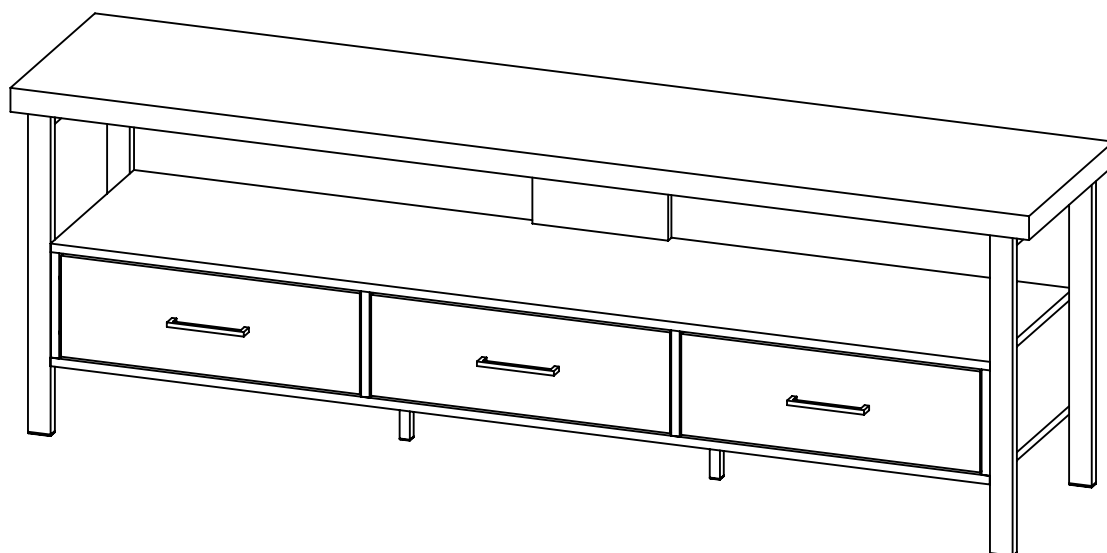

ITEM: 721891

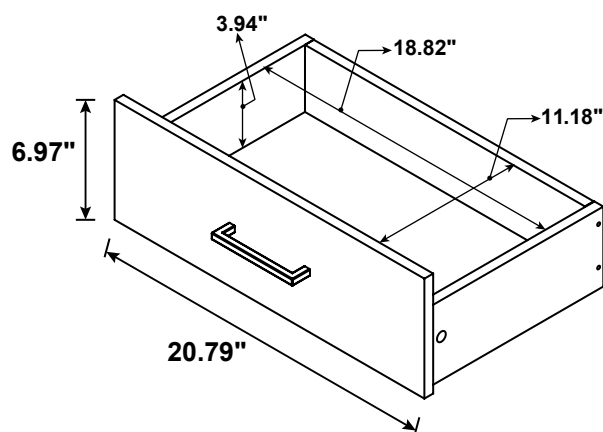
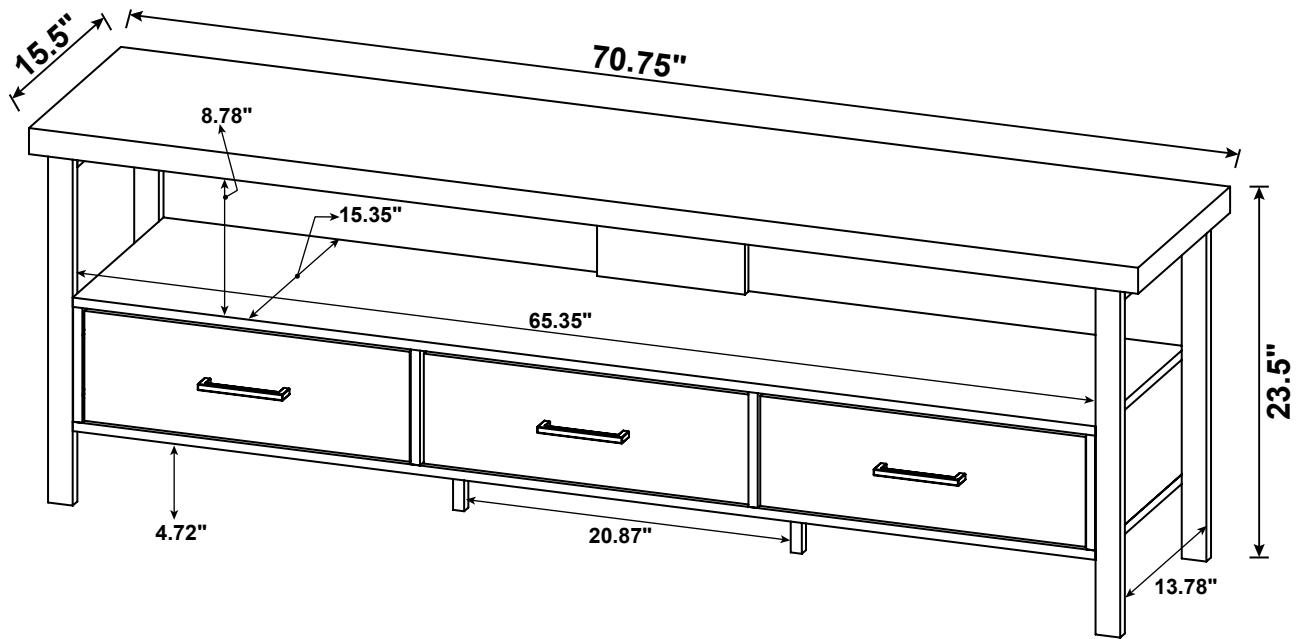

Note : Dimension tolerance $\pm 5\%$