

*ASSEMBLY INSTRUCTIONS*  
*COASTER FINE FURNITURE*

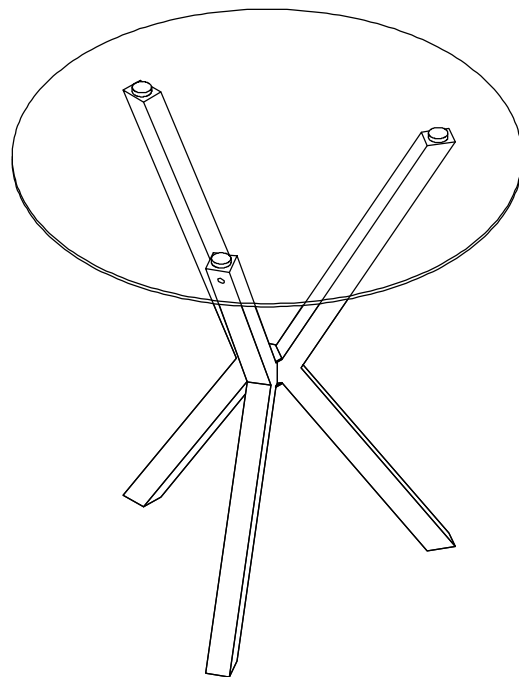

*Fine Furniture for every stage of life*

100186  
**BAR TABLE**

REVISION 0 : 12/12/2019  
REVISION 1 : 08/26/2022

ITEM:100186



# ASSEMBLY INSTRUCTIONS

## ASSEMBLY TIPS:

1. Remove hardware from box and sort by size.
2. Please check to see that all hardware and parts are present prior to start of assembly.
3. Please follow attached instructions in the same sequence as numbered to assure fast & easy assembly.



## WARNING!

1. Don't attempt to repair or modify parts that are broken or defective. Please contact the store immediately.
2. This product is for home use only and not intended for commercial establishments.

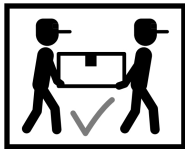

ASSEMBLY TIME 15 MINUTES

## PARTS IDENTIFICATION

B1: TOP

AN GLASS TOP

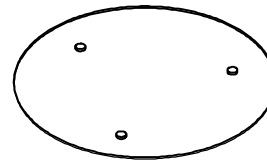

1PC

B2: BASE

BN METAL LEG



3PCS

CN TRIANGLE TOP COVER

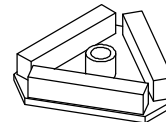

1PC

DN TRIANGLE BOTTOM COVER

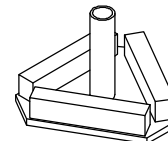

1PC

## HARDWARE IDENTIFICATION

1 SHORT BOLT  
( $\phi$ 1/4" x 35mm SR)



3PCS

3 ADHESIVE



3PCS

2 LONG BOLT  
( $\phi$ 1/4" x 56mm SR)

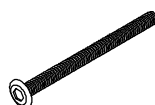

1PC

4 ALLEN WRENCH  
(4mm)

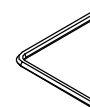

1PC

HARDWARE PACK IS LOCATED IN 100186 (B2)

ITEM:100186



# ASSEMBLY INSTRUCTIONS

**STEP 1** Do not tighten until each step is completed or instructed.

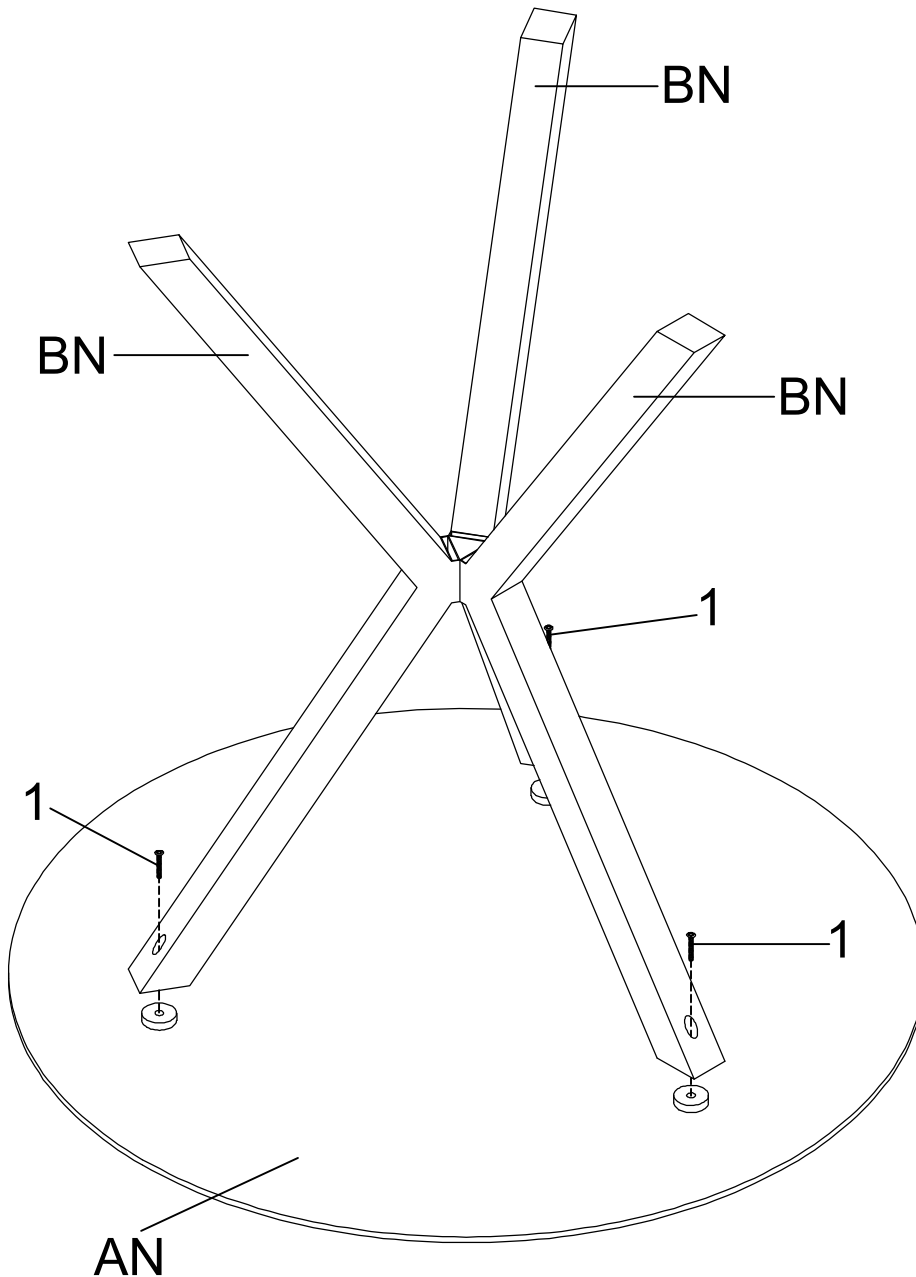

ITEM:100186

# ASSEMBLY INSTRUCTIONS

STEP 2

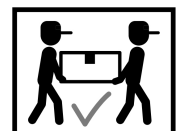
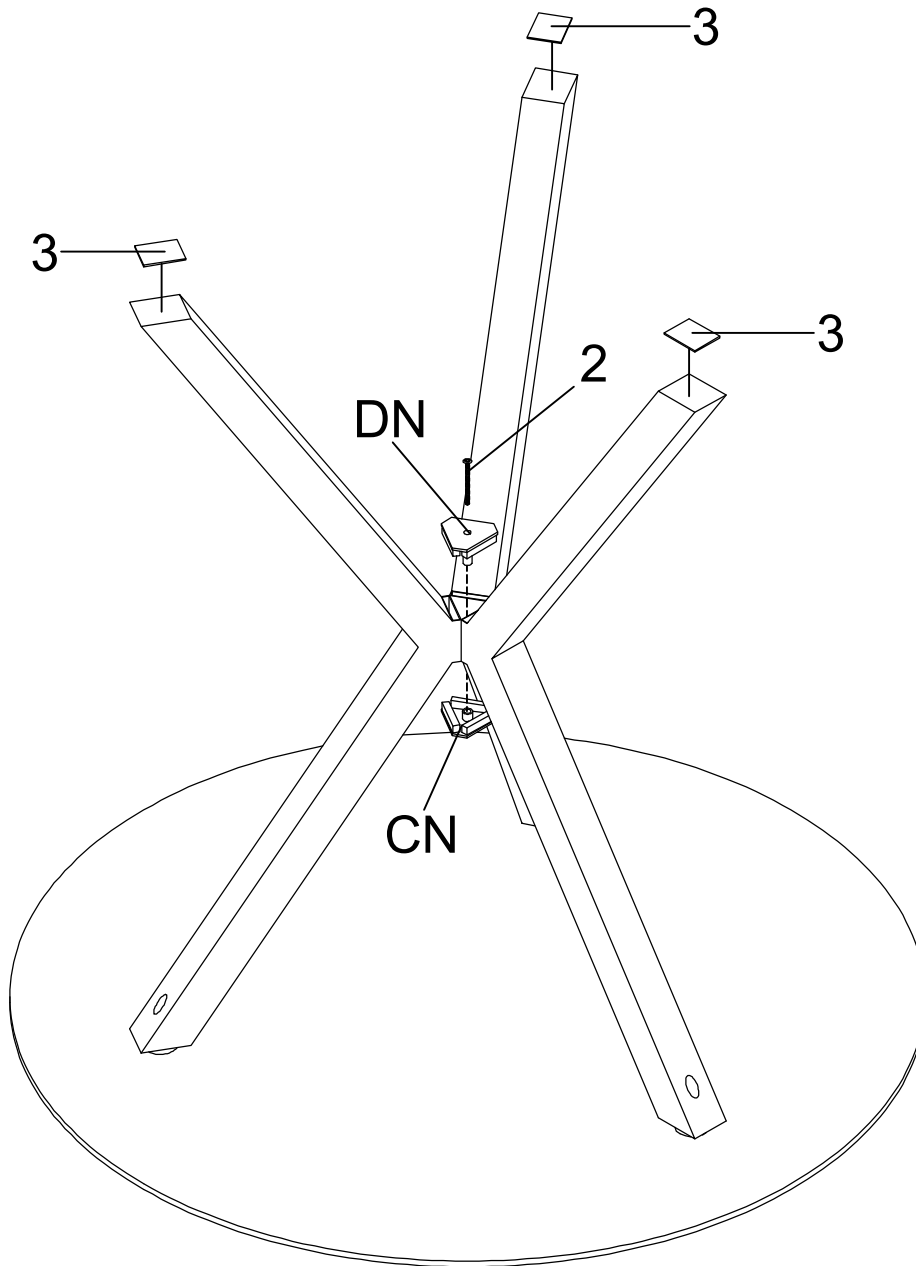

# ITEM:100186 ASSEMBLY INSTRUCTIONS



<b>Product Size : 889 DIA X 1048H (MM)</b>
<b>Product Size : 35" DIA X 41 <math>\frac{1}{4}</math>"</b>

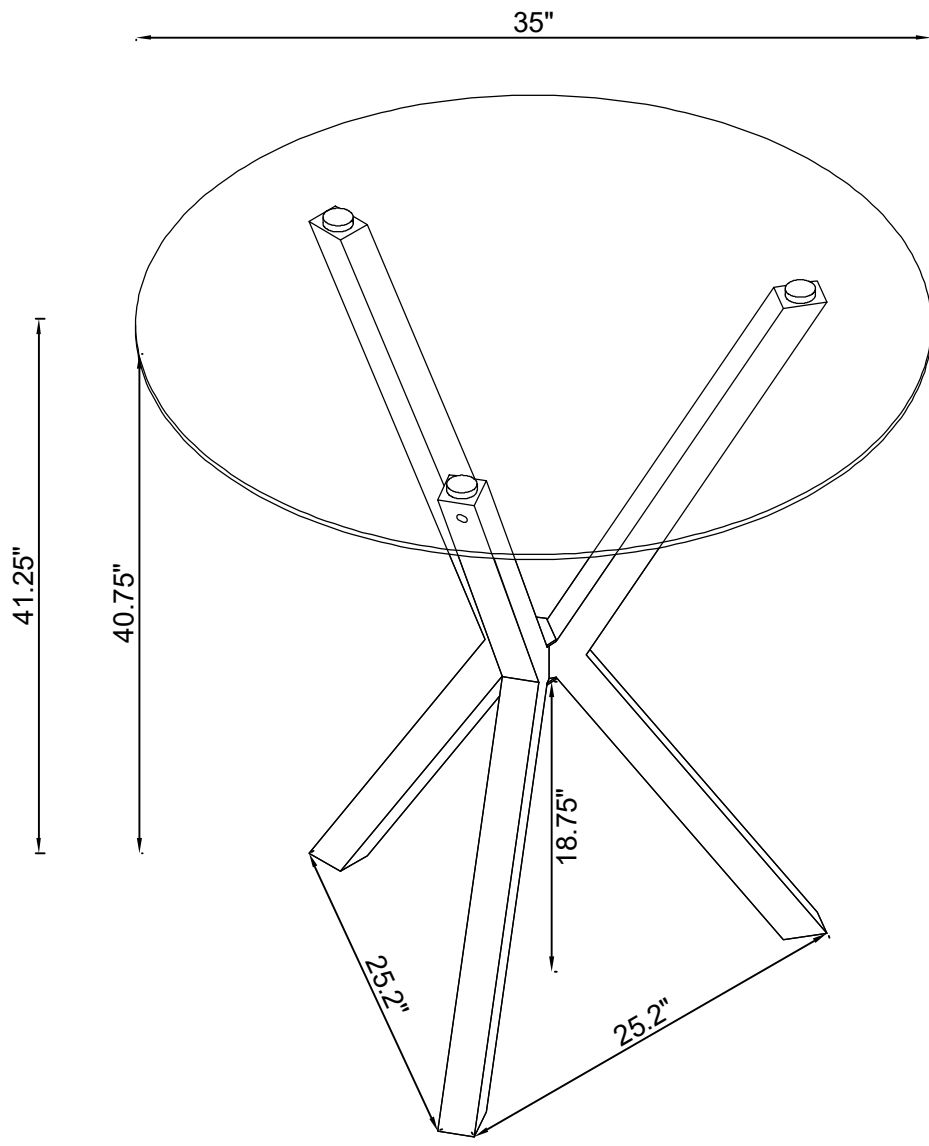

Note : Dimension tolerance  $\pm 5\%$