

**ASSEMBLY INSTRUCTIONS**  
**COASTER FINE FURNITURE**

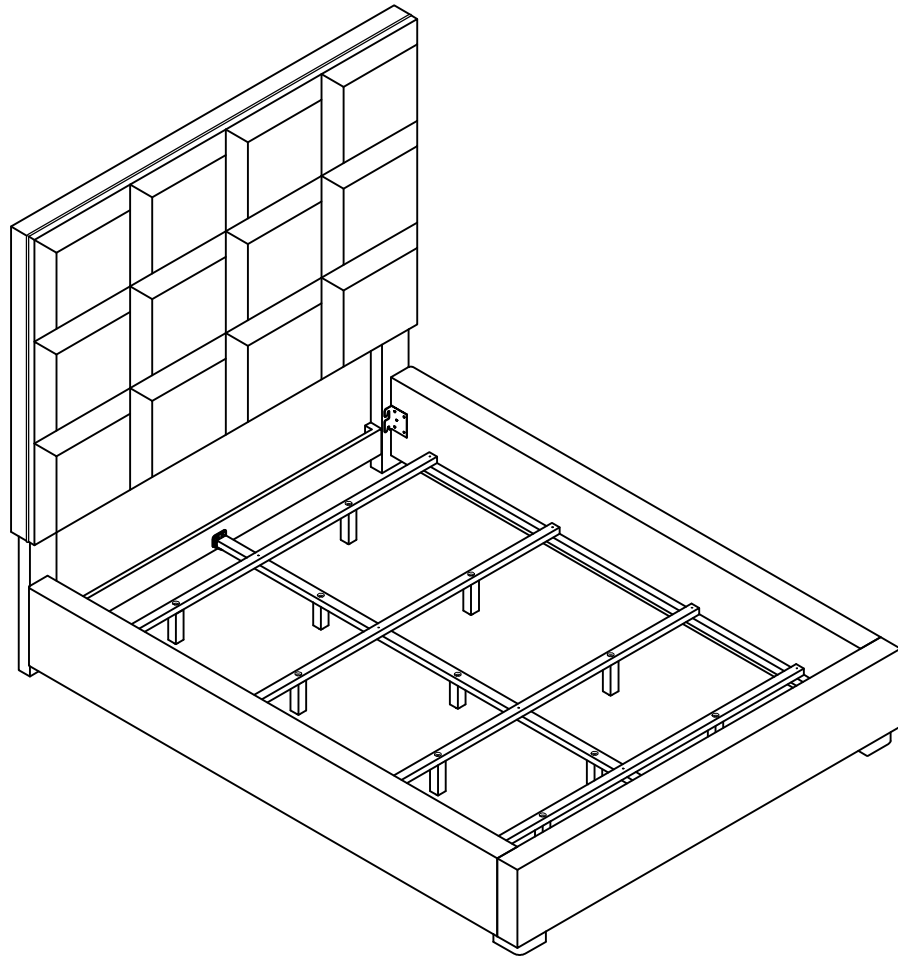

*Fine Furniture for every stage of life*

**315850Q(B1&B2)**  
**Queen Bed**

# ITEM: 315850Q(B1&B2)



## ASSEMBLY INSTRUCTIONS

### ASSEMBLY TIPS:

1. Remove hardware from box and sort by size.
2. Please check to see that all hardware and parts are present prior to start of assembly.
3. Please follow attached instructions in the same sequence as numbered to assure fast & easy assembly.



### WARNING!

1. Don't attempt to repair or modify parts that are broken or defective. Please contact the store immediately.
2. This product is for home use only and not intended for commercial establishments.

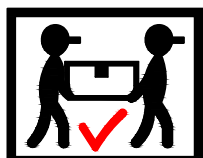

ASSEMBLY TIME

30 MINUTES

## PARTS IDENTIFICATION

### B1(BOX1):

A HEADBOARD PANEL

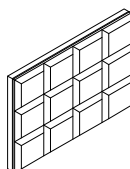

1PC

C RIGHT HEADBOARD LEG



1PC

### B2(BOX2):

E FOOTBOARD PANEL

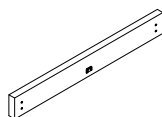

1PC

G RIGHT FOOTBOARD LEG

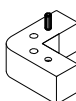

1PC

I CENTER RAIL

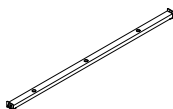

1PC

K BED SLAT SUPPORT WITH LEVELER

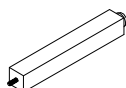

8PCS

HB

315850Q(B1)  
FROM BOX1  
HEADBOARD  
COMPLETE

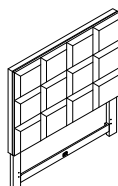

1PC

B LEFT HEADBOARD LEG

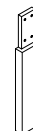

1PC

D HEADBOARD BOTTOM RAIL

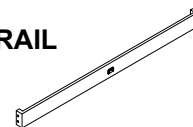

1PC

F LEFT FOOTBOARD LEG

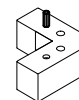

1PC

H BED RAIL

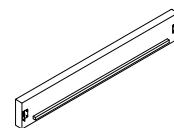

2PCS

J BED SLAT

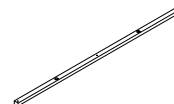

4PCS

L CENTER RAIL SUPPORT WITH LEVELER

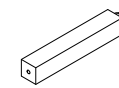

3PCS

FB

315850Q(B2)  
FROM BOX2  
FOOTBOARD  
COMPLETE

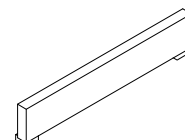

1PC

# ITEM: 315850Q(B1&B2)



## ASSEMBLY INSTRUCTIONS

### ASSEMBLY TIPS:

1. Remove hardware from box and sort by size.
2. Please check to see that all hardware and parts are present prior to start of assembly.
3. Please follow attached instructions in the same sequence as numbered to assure fast & easy assembly.







### WARNING!







1. Don't attempt to repair or modify parts that are broken or defective. Please contact the store immediately.
2. This product is for home use only and not intended for commercial establishments.

## HARDWARE IDENTIFICATION

### Z-B1(BOX1)-HARDWARE PACK IS LOCATED IN 315850Q(B1)

1	<b>BOLT</b> (Ø5/16"x50mm-RBW)		12PCS	2	<b>LOCK WASHER</b> (Ø5/16"-RBW)		12PCS
3	<b>FLAT WASHER</b> (Ø5/16"-RBW)		12PCS	4	<b>ALLEN WRENCH</b> (5MM-RBW)		1PC

### Z-B2(BOX2)-HARDWARE PACK IS LOCATED IN 315850Q(B2)

5	<b>LONG BOLT</b> (Ø5/16"x64mm-RBW)		2PCS	6	<b>SHORT BOLT</b> (Ø5/16"x38mm-RBW)		19PCS
7	<b>FLAT WASHER</b> (Ø5/16"-RBW)		21PCS	8	<b>LOCK WASHER</b> (Ø5/16"-RBW)		10PCS
9	<b>ALLEN WRENCH</b> (5MM-RBW)		1PC	10	<b>SHORT PAN HEAD SCREW</b> (M4x19mm-RBW)		4PCS
11	<b>LONG PAN HEAD SCREW</b> (M4x38mm-RBW)		12PCS				

### NOTE:

Phillips head screw driver is required in the assembly process; however, manufacturer does not provide this item.

# ITEM: 315850Q(B1&B2)



## ASSEMBLY INSTRUCTIONS

### STEP 1

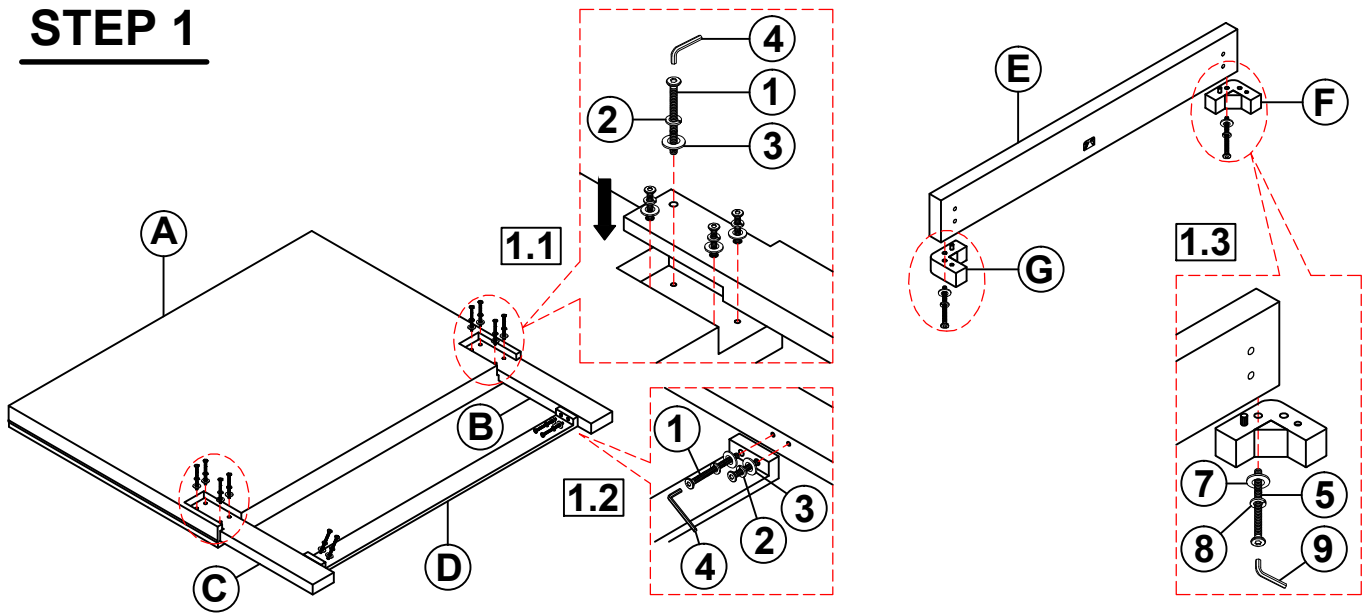

### STEP 2

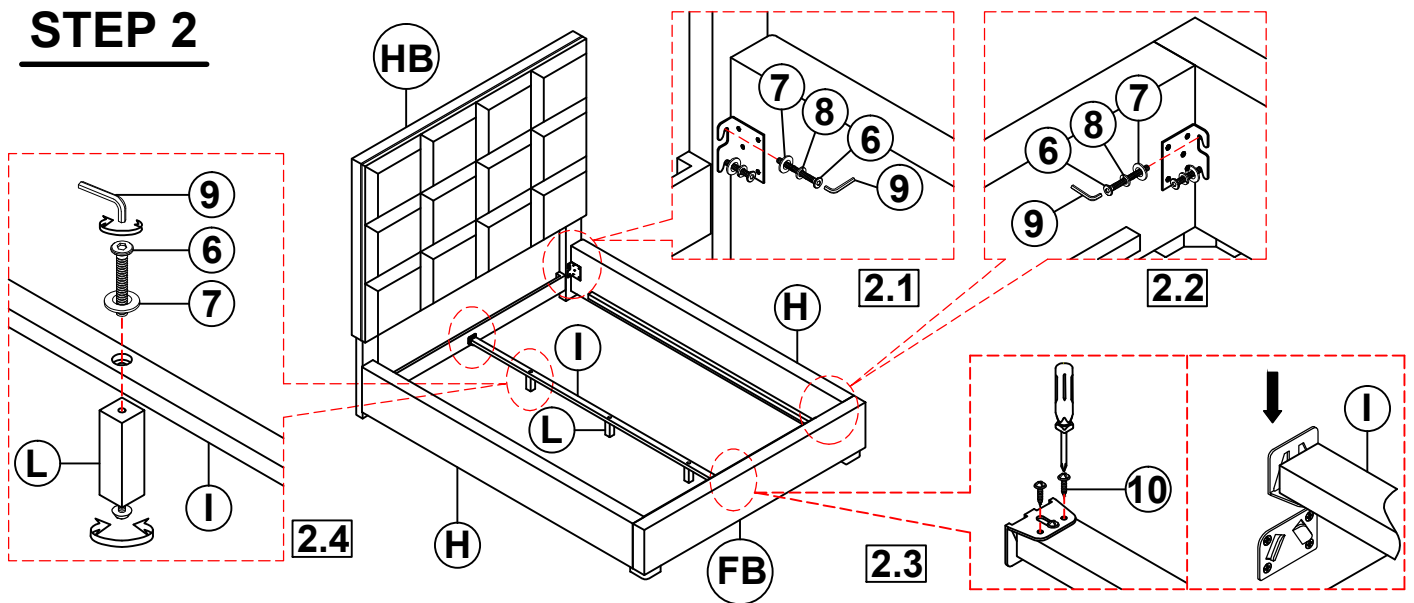

### STEP 3

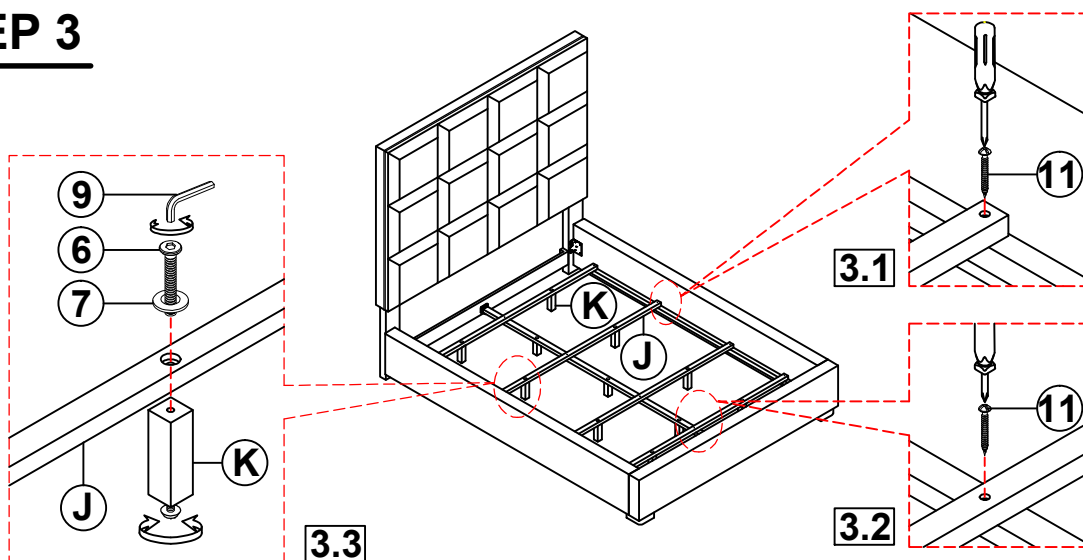

ITEM: **315850Q(B1&B2)**

**ASSEMBLY INSTRUCTIONS**

**STEP 4**

**COMPLETE**

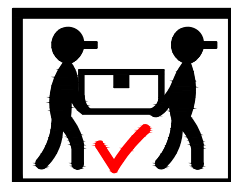
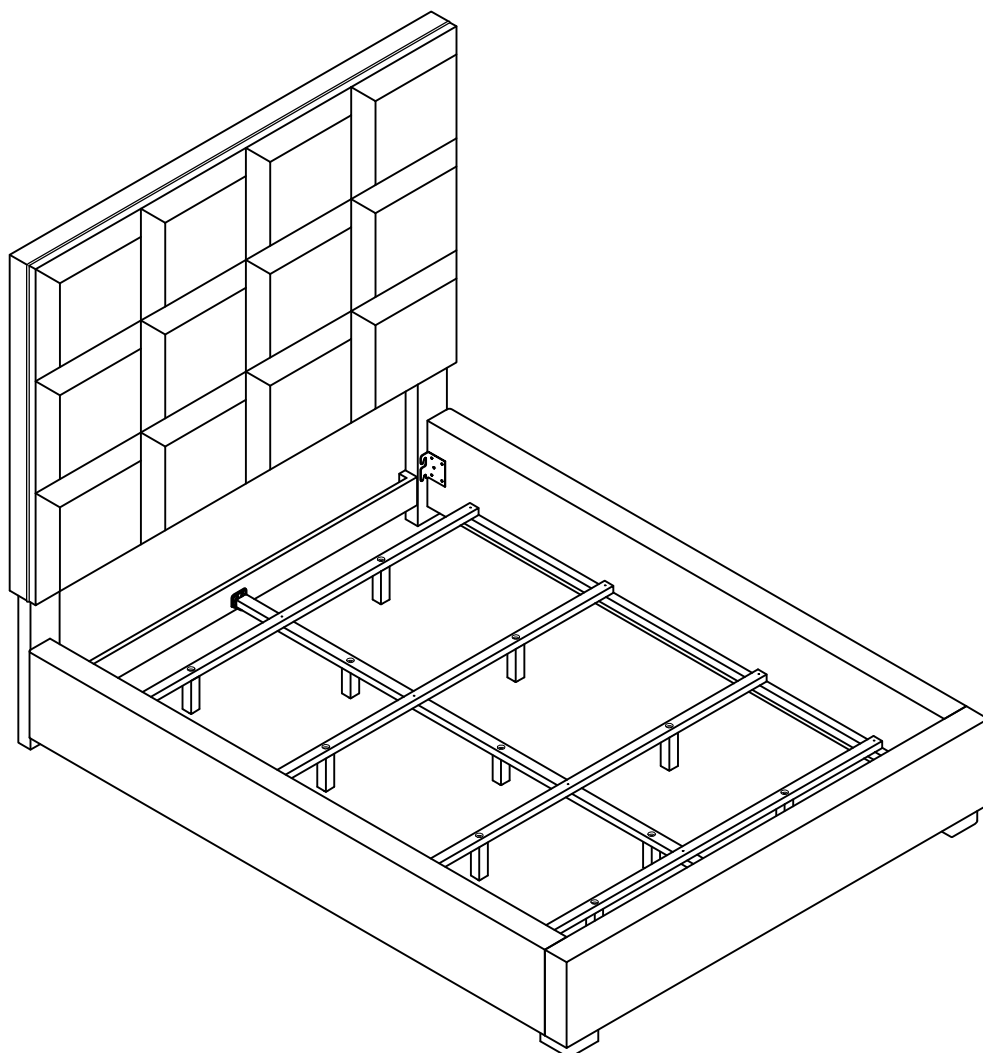

ITEM: 315850Q(B1&B2)



Inner Size : 61.00"W X 80.50"D

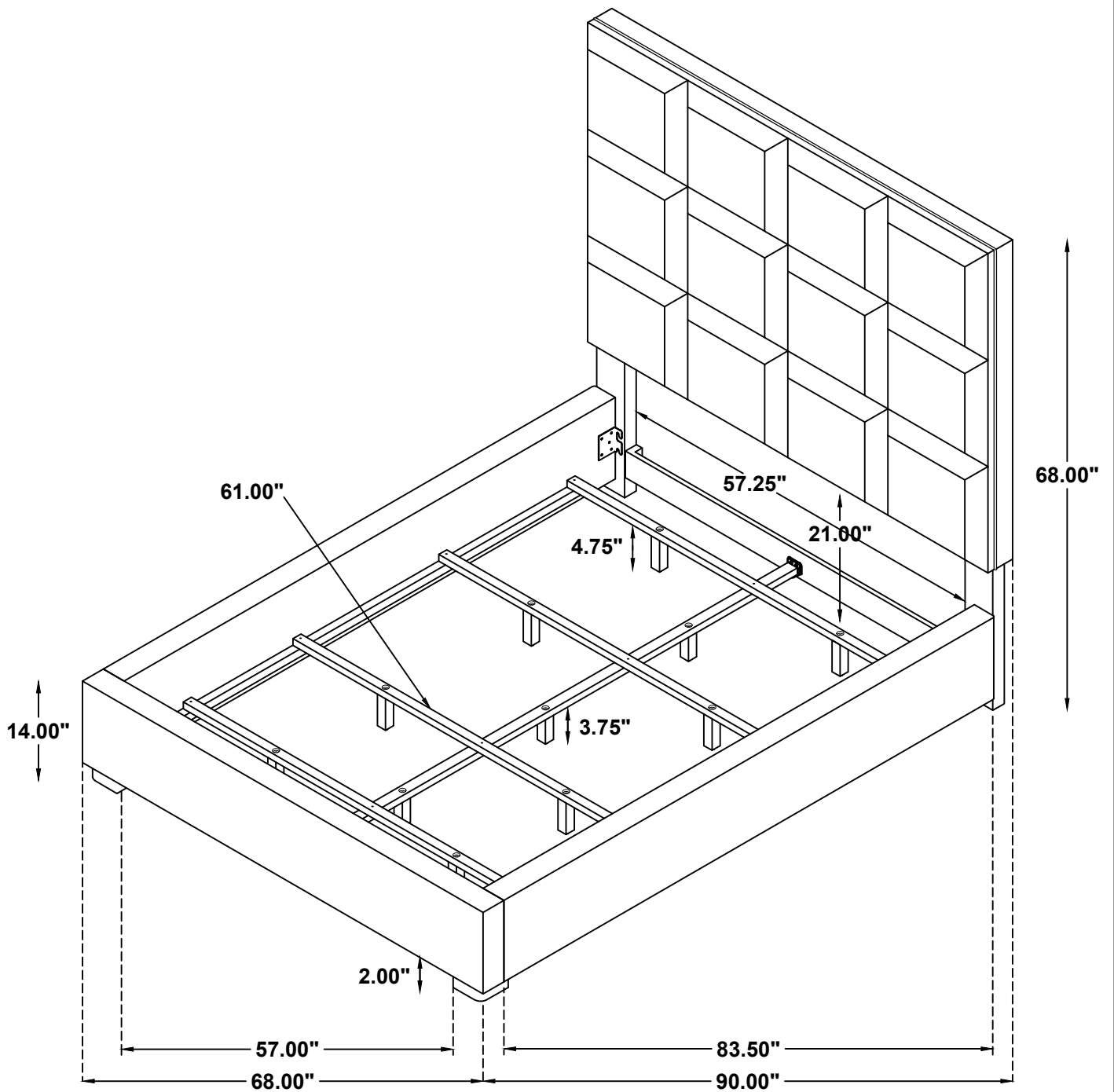

Note :Dimension tolerance  $\pm 5\%$