

ASSEMBLY INSTRUCTIONS
COASTER FINE FURNITURE

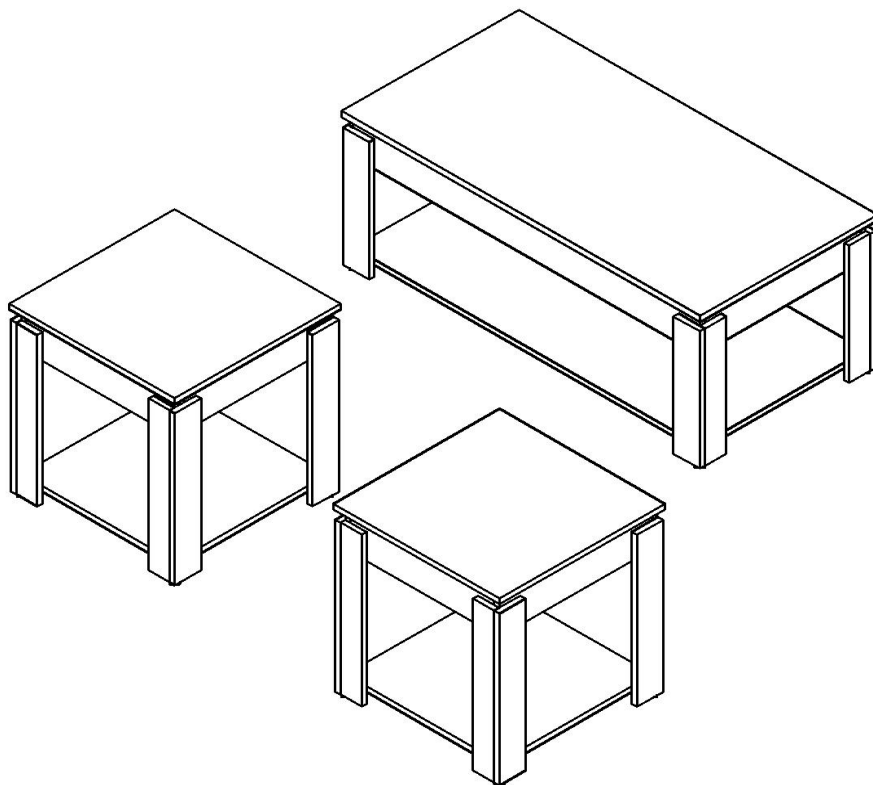

Fine Furniture for every stage of life

736145
3Pc Occasional Set

ITEM: **736145**



ASSEMBLY INSTRUCTIONS

ASSEMBLY TIPS:

1. Remove hardware from box and sort by size.
2. Please check to see that all hardware and parts are present prior to start of assembly.
3. Please follow attached instructions in the same sequence as numbered to assure fast & easy assembly.



WARNING!







1. Don't attempt to repair or modify parts that are broken or defective. Please contact the store immediately.
2. This product is for home use only and not intended for commercial establishments.



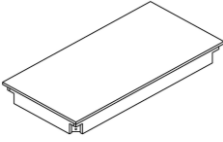
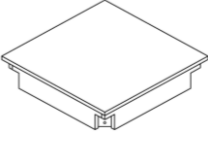

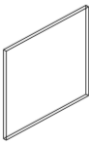

ASSEMBLY TIME

30 MINUTES

PARTS IDENTIFICATION

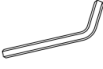
A	COFFEE TABLE TOP		1PC	E	END TABLE TOP		2PCS
B	LEFT COFFEE TABLE LEG (WITH "L" LABEL)		2PCS	F	LEFT END TABLE LEG (WITH "L" LABEL)		4PCS
C	RIGHT COFFEE TABLE LEG (WITH "R" LABEL)		2PCS	G	RIGHT END TABLE LEG (WITH "R" LABEL)		4PCS
D	COFFEE TABLE BASE		1PC	H	END TABLE BASE		2PCS

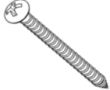
HARDWARE IDENTIFICATION

1	BOLT (M6 x 60mm - BLK)		24PCS	4	ALLEN WRENCH (M4 x 65mm - BLK)		1PC
2	LOCK WASHER (M6 - BLK)		24PCS	5	PAN HEAD SCREW (M4 x 30mm - BLK)		12PCS
3	FLAT WASHER (M6 x 19mm - BLK)		24PCS				

NOTE:

Phillips head screw driver is required in the assembly process; however, manufacturer does not provide this item.

ITEM: **736145**

ASSEMBLY INSTRUCTIONS

COFFEE TABLE

STEP 1

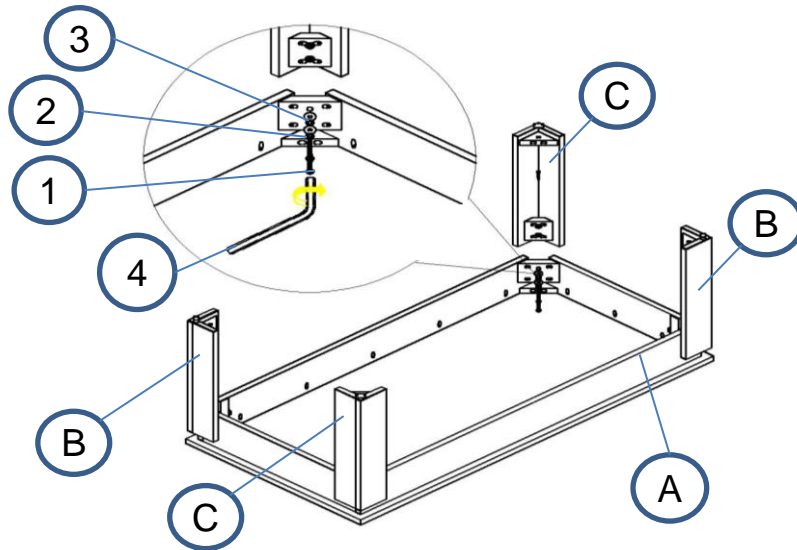

STEP 2

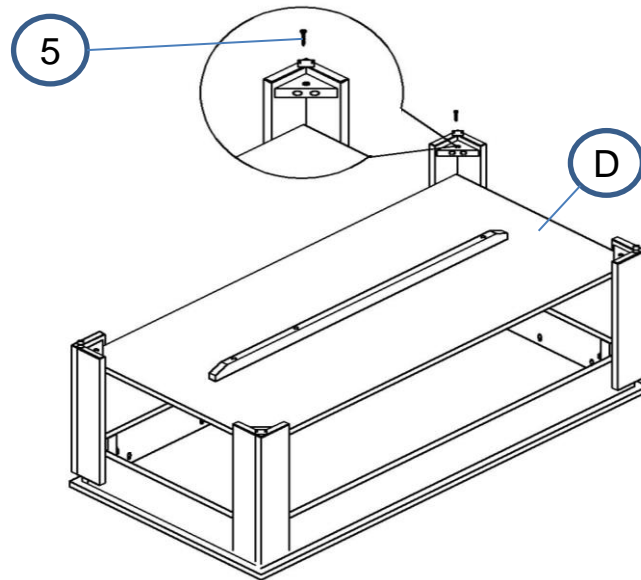

STEP 3
COMPLETE

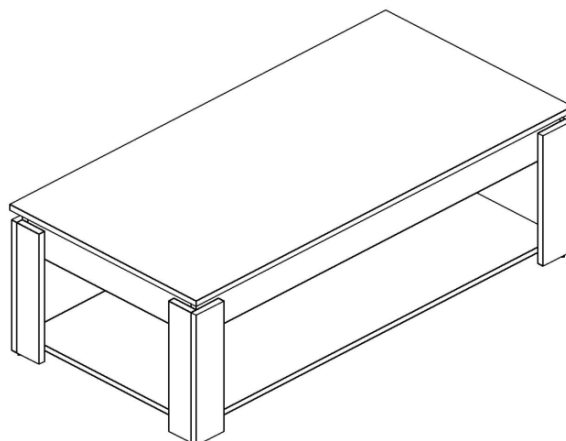

ITEM: 736145

ASSEMBLY INSTRUCTIONS
END TABLE

STEP 4

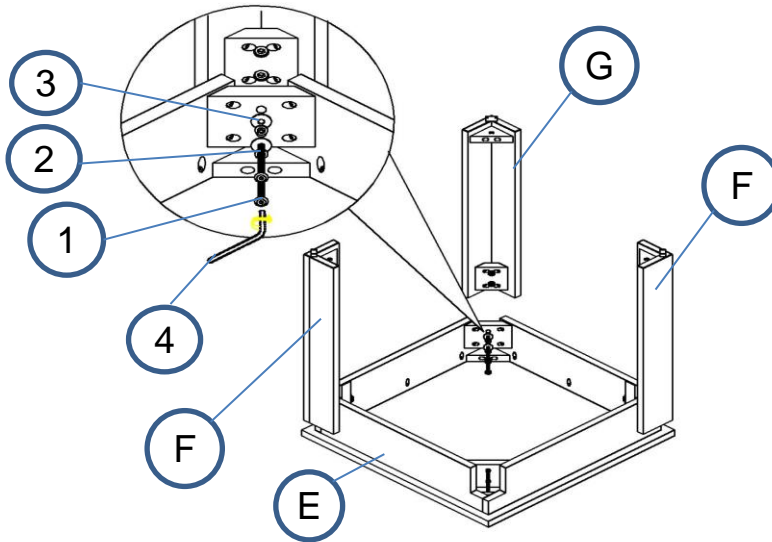

STEP 5

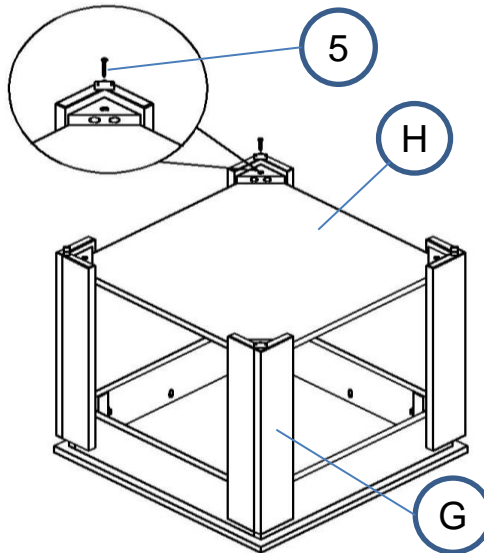

STEP 6
COMPLETE

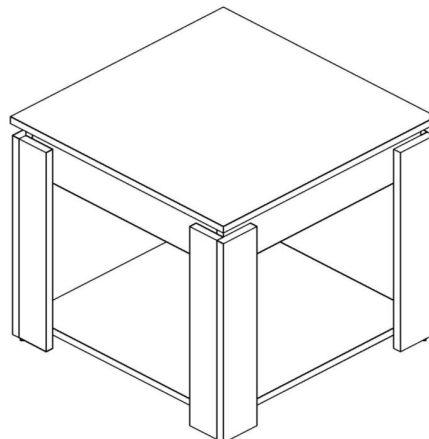

ITEM: 736145

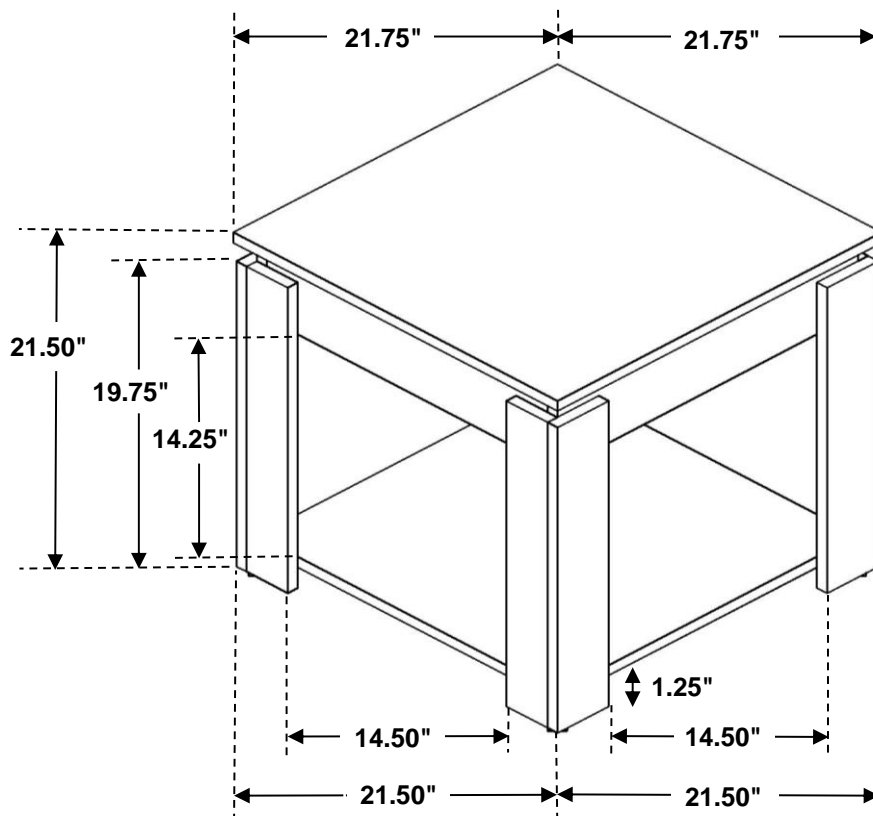
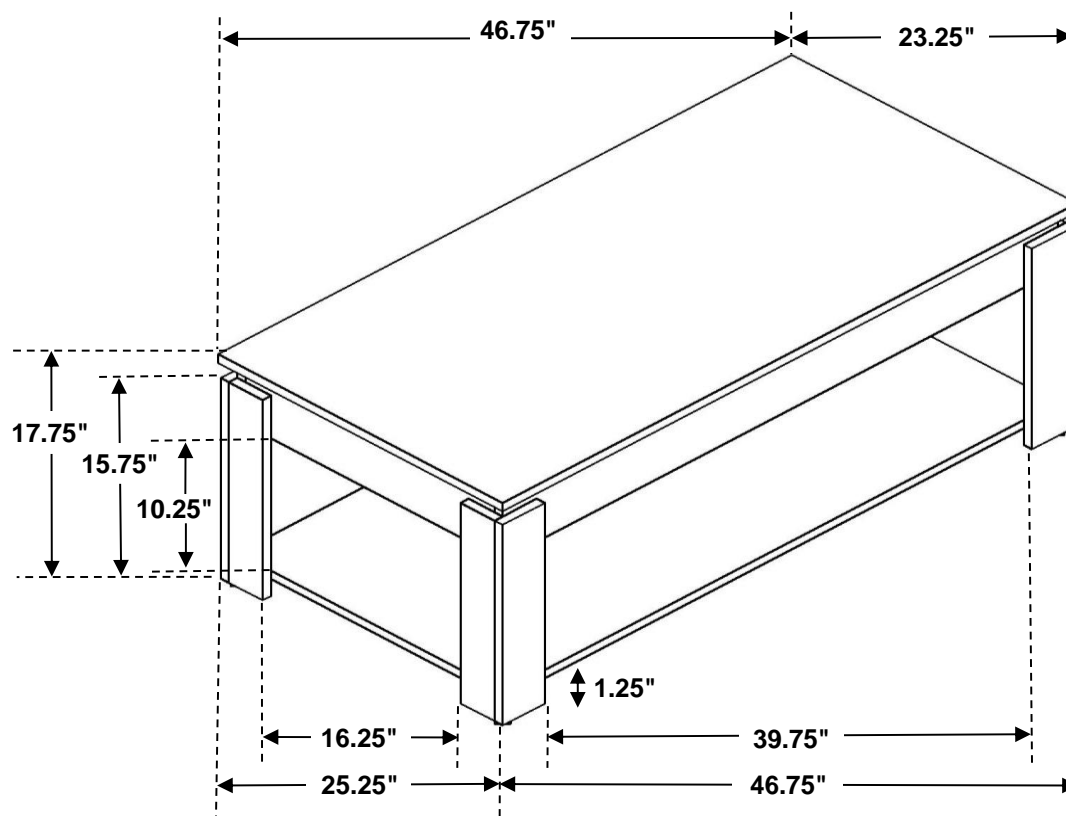

Note : Dimension tolerance $\pm 5\%$