



ASSEMBLY INSTRUCTIONS

COASTER FINE FURNITURE



Fine Furniture for every stage of life

223250SKE (B1-B3)

Eastern King Storage Bed

REVISION 0: 06/27/2018
REVISION 1: 04/22/2019
REVISION 2: 08/27/2019
REVISION 3: 01/11/2021

ITEM: 223250SKE (B1-B3)



ASSEMBLY INSTRUCTIONS

ASSEMBLY TIPS:

1. Remove hardware from box and sort by size.
2. Please check to see that all hardware and parts are present prior to start of assembly.
3. Please follow attached instructions in the same sequence as numbered to assure fast & easy assembly.



WARNING!

1. Don't attempt to repair or modify parts that are broken or defective. Please contact the store immediately.
2. This product is for home use only and not intended for commercial establishments.

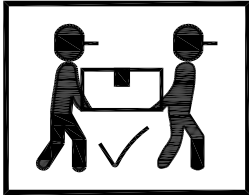

ASSEMBLY TIME

30 MINUTES

PARTS IDENTIFICATION

B1 (BOX 1)

A HEADBOARD PANEL

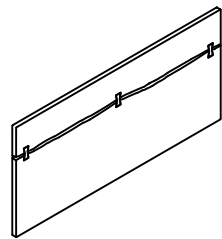

1PC

B HEADBOARD LEG

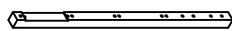

2PCS

C CENTER RAIL SUPPORT



1PC

B2 (BOX 2)

D FOOTBOARD

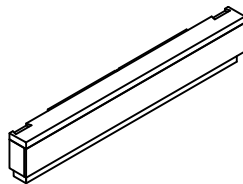

1PC

B3 (BOX 3)

E RIGHT STORAGE SIDE RAIL

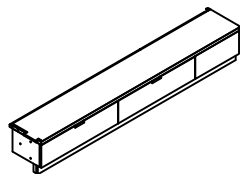

1PC

F LEFT STORAGE SIDE RAIL

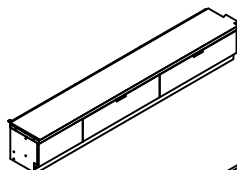

1PC

G TRESTLE BAR

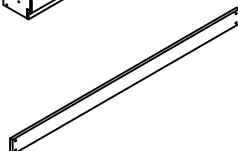

1PC

H CENTER RAIL

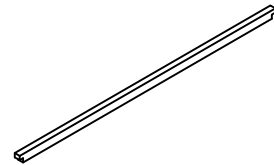

1PC

I ROLL SLAT (13PCS)

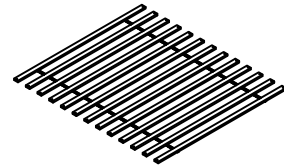

1SET

J CENTER RAIL SUPPORT WITH LEVELER



3PCS

K CONCEAL PANEL

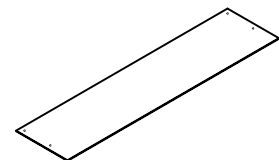

1PC

L DRAWER SUPPORT LEG WITHOUT LEVELER



4PCS

HB 223250SKE (B1)
* FROM BOX 1
HEADBOARD COMPLETE

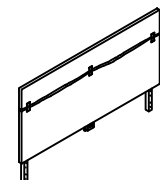

1PC

D 223250SKE (B2)
* FROM BOX 2
FOOTBOARD

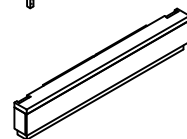

1PC

NOTE :

Phillips head screw driver is required in the assembly process; however, manufacturer does not provide this item.

ITEM: 223250SKE (B1-B3)



ASSEMBLY INSTRUCTIONS

ASSEMBLY TIPS:

1. Remove hardware from box and sort by size.
2. Please check to see that all hardware and parts are present prior to start of assembly.
3. Please follow attached instructions in the same sequence as numbered to assure fast & easy assembly.









WARNING!



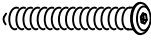
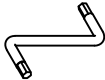





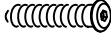

1. Don't attempt to repair or modify parts that are broken or defective. Please contact the store immediately.
2. This product is for home use only and not intended for commercial establishments.

HARDWARE IDENTIFICATION

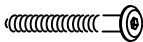
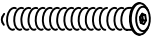
Z - B1 (BOX 1) - HARDWARE PACK IS LOCATED IN 223250SKE (B1)

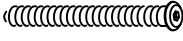
1	SHORT BOLT (M6 x 40mm - BLK)		2PCS	5	BIG FLAT WASHER (Ø20 x Ø8 x 2mm - BLK)		8PCS
2	LONG BOLT (M8 x 60mm - BLK)		8PCS	6	Z-ALLEN WRENCH (4mm - WHT)		1PC
3	LOCK WASHER (Ø13 x Ø8 x 2mm - BLK)		10PCS	7	ALLEN WRENCH (5mm - BLK)		1PC
4	SMALL FLAT WASHER (Ø16 x Ø6.5 x 1mm - BLK)		2PCS				

Z - B3 (BOX 3) - HARDWARE PACK IS LOCATED IN 223250SKE (B3)

8	BOLT 1 (M8 x 20mm - BLK)		2PCS	14	BIG FLAT WASHER (Ø20 x Ø8 x 2mm - BLK)		16PCS
9	BOLT 2 (M8 x 40mm - BLK)		4PCS	15	SMALL FLAT WASHER (Ø16 x Ø6.5 x 1mm - BLK)		2PCS
10	BOLT 3 (M6 x 50mm - BLK)		2PCS	16	Z-ALLEN WRENCH (4mm - WHT)		1PC
11	BOLT 4 (M8 x 50mm - BLK)		6PCS	17	ALLEN WRENCH (5mm - BLK)		1PC
12	BOLT 5 (M8 x 60mm - BLK)		4PCS	18	LONG PAN HEAD SCREW (Ø7 x Ø1 1/4" - BLK)		26PCS
13	LOCK WASHER (Ø13 x Ø8 x 2mm - BLK)		18PCS	19	SHORT PAN HEAD SCREW (Ø6 x Ø5/8" - BLK)		4PCS

NOTE :

Phillips head screw driver is required in the assembly process; however, manufacturer does not provide this item.

ITEM: 223250SKE (B1-B3)

ASSEMBLY INSTRUCTIONS



STEP 1

X - DONT USE , ✓ - USED

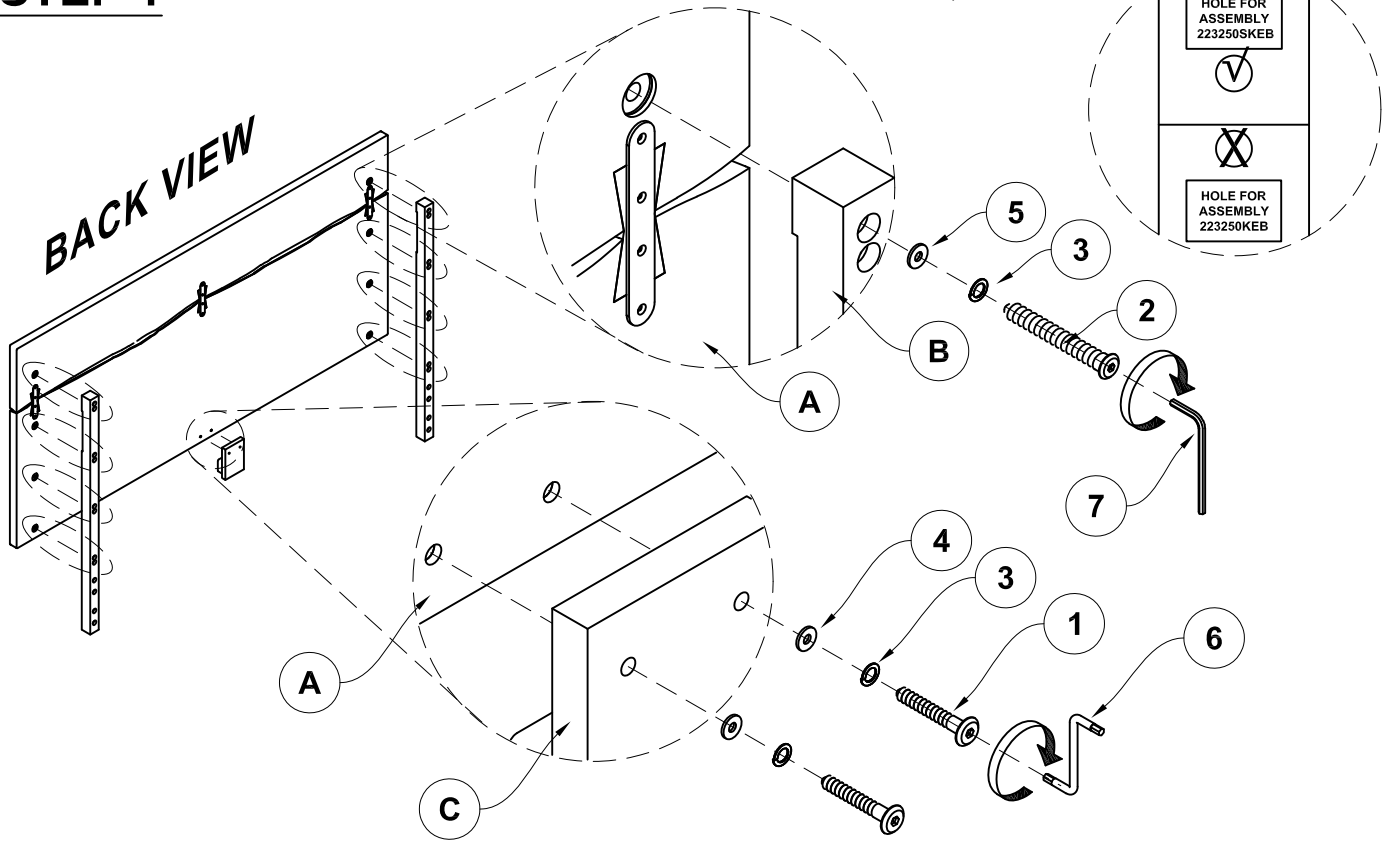

STEP 2

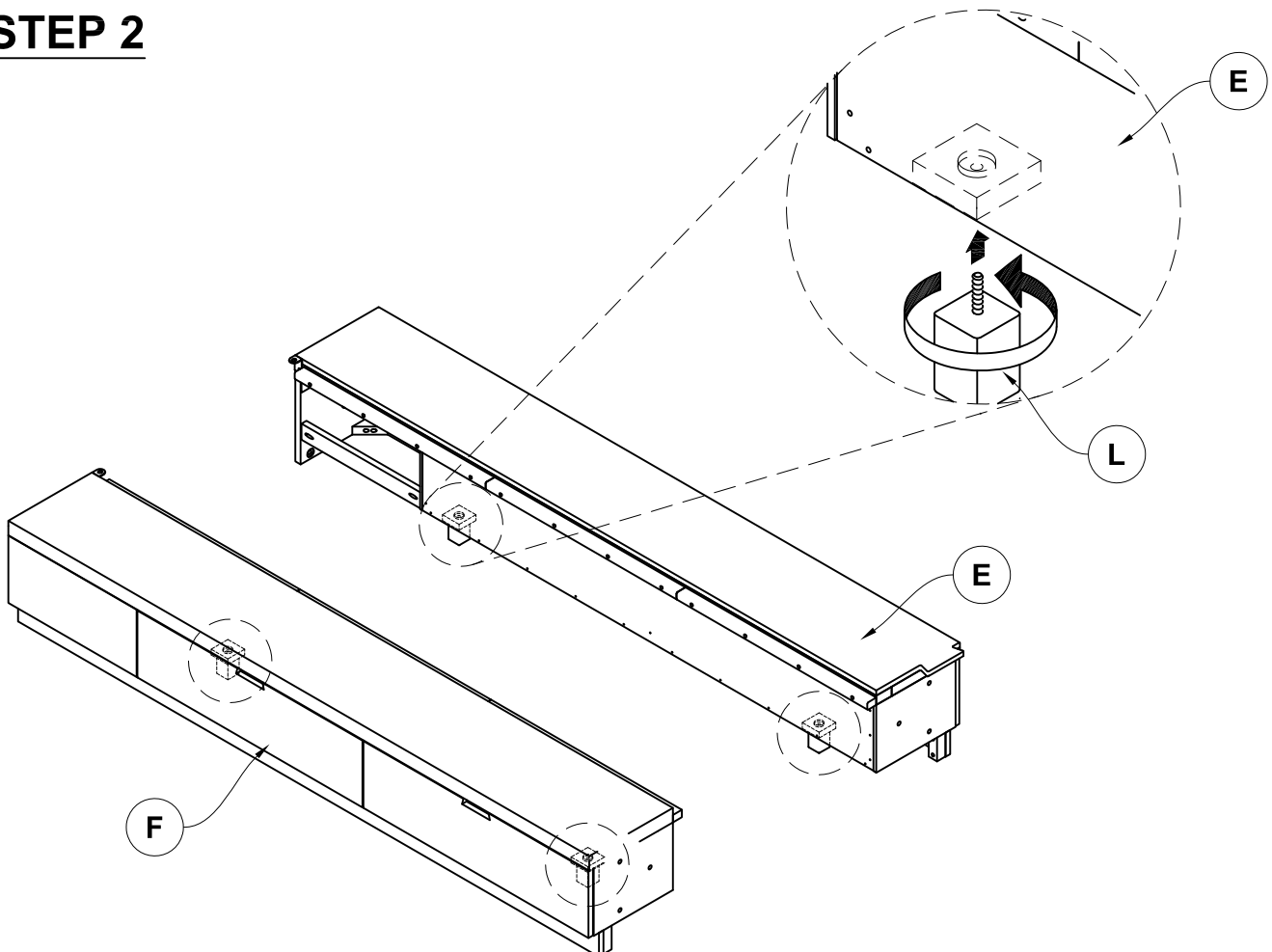

ITEM: 223250SKE (B1-B3)

ASSEMBLY INSTRUCTIONS



STEP 3

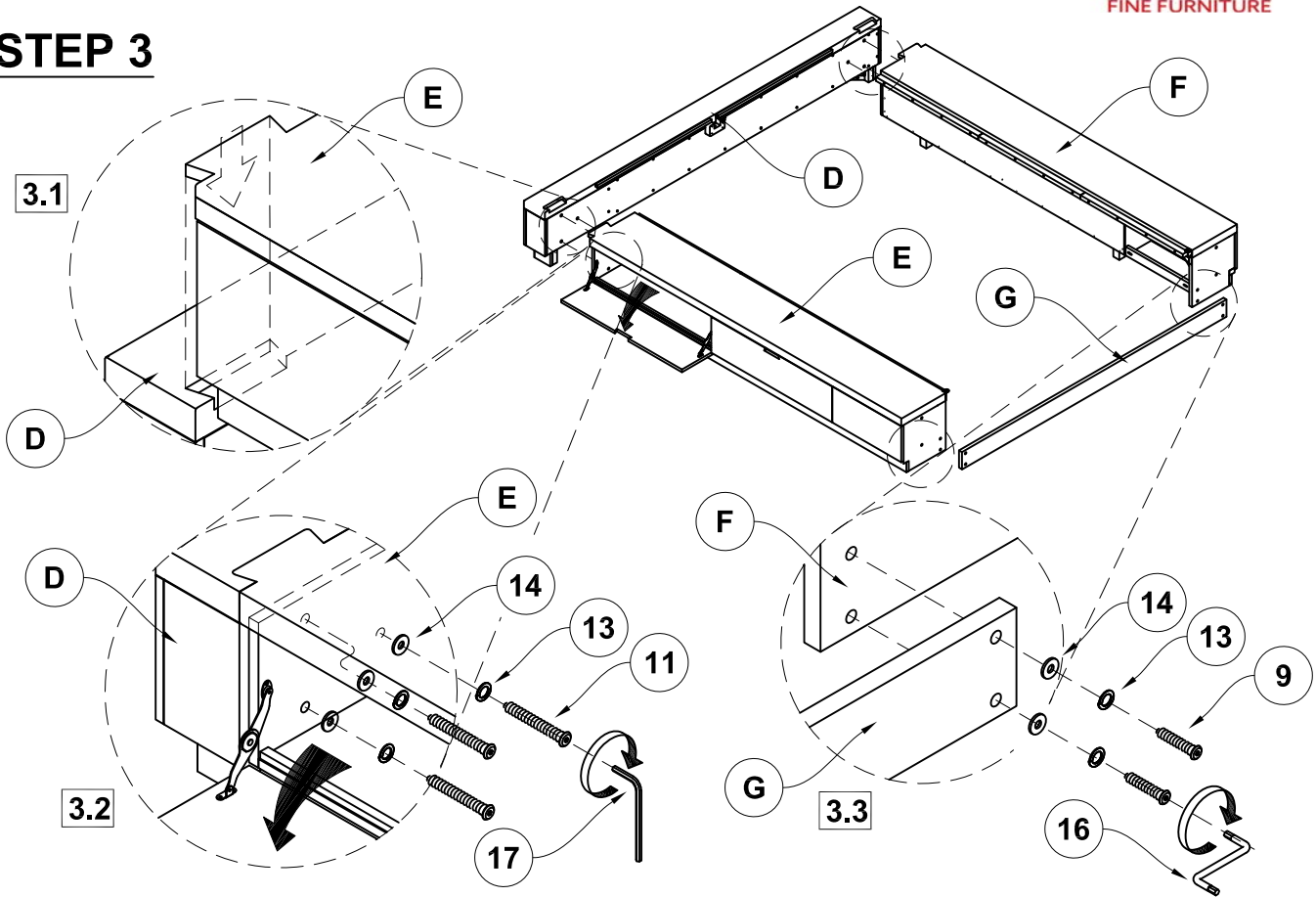

STEP 4

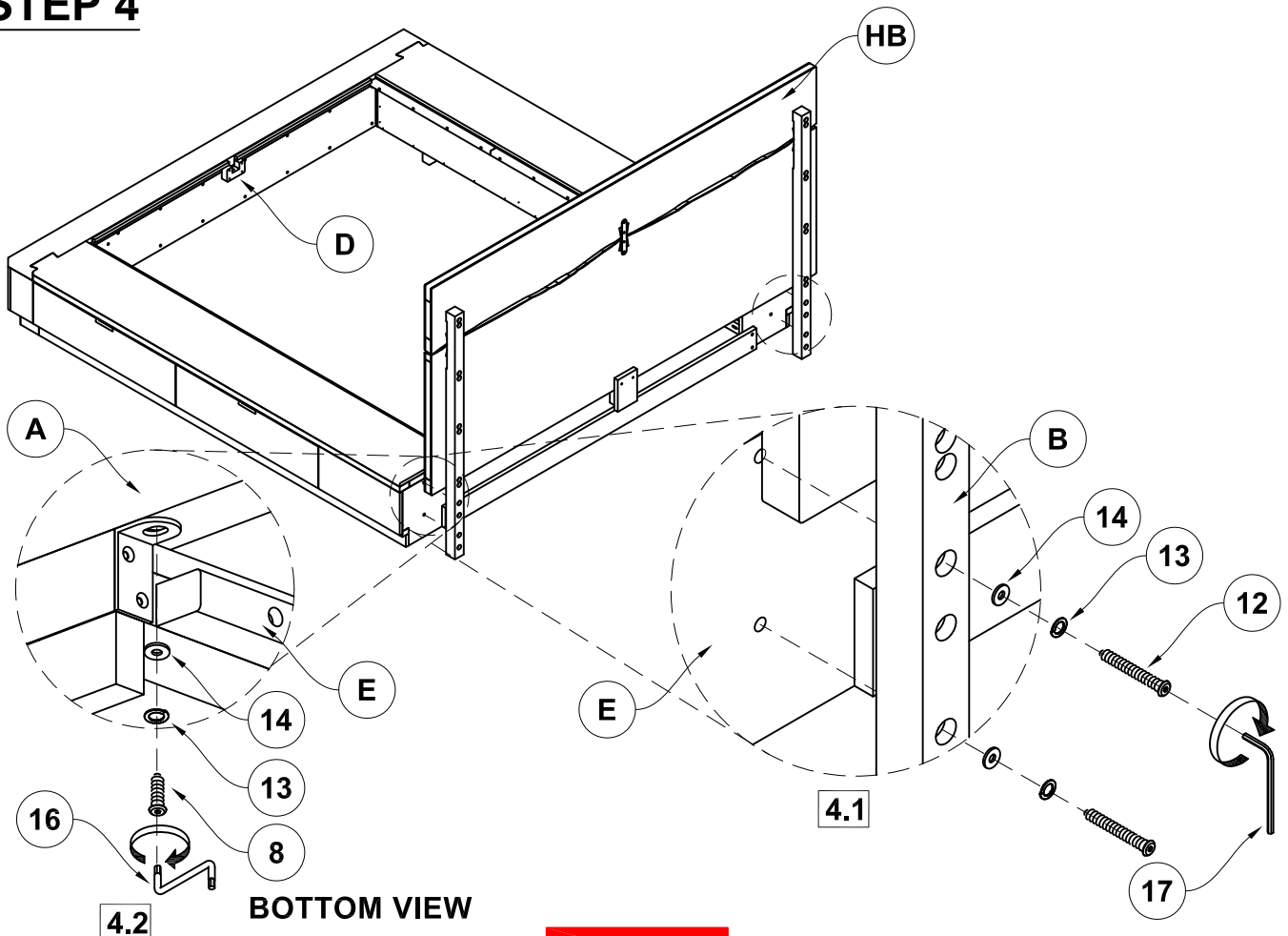

ITEM: 223250SKE (B1-B3)

ASSEMBLY INSTRUCTIONS



STEP 5

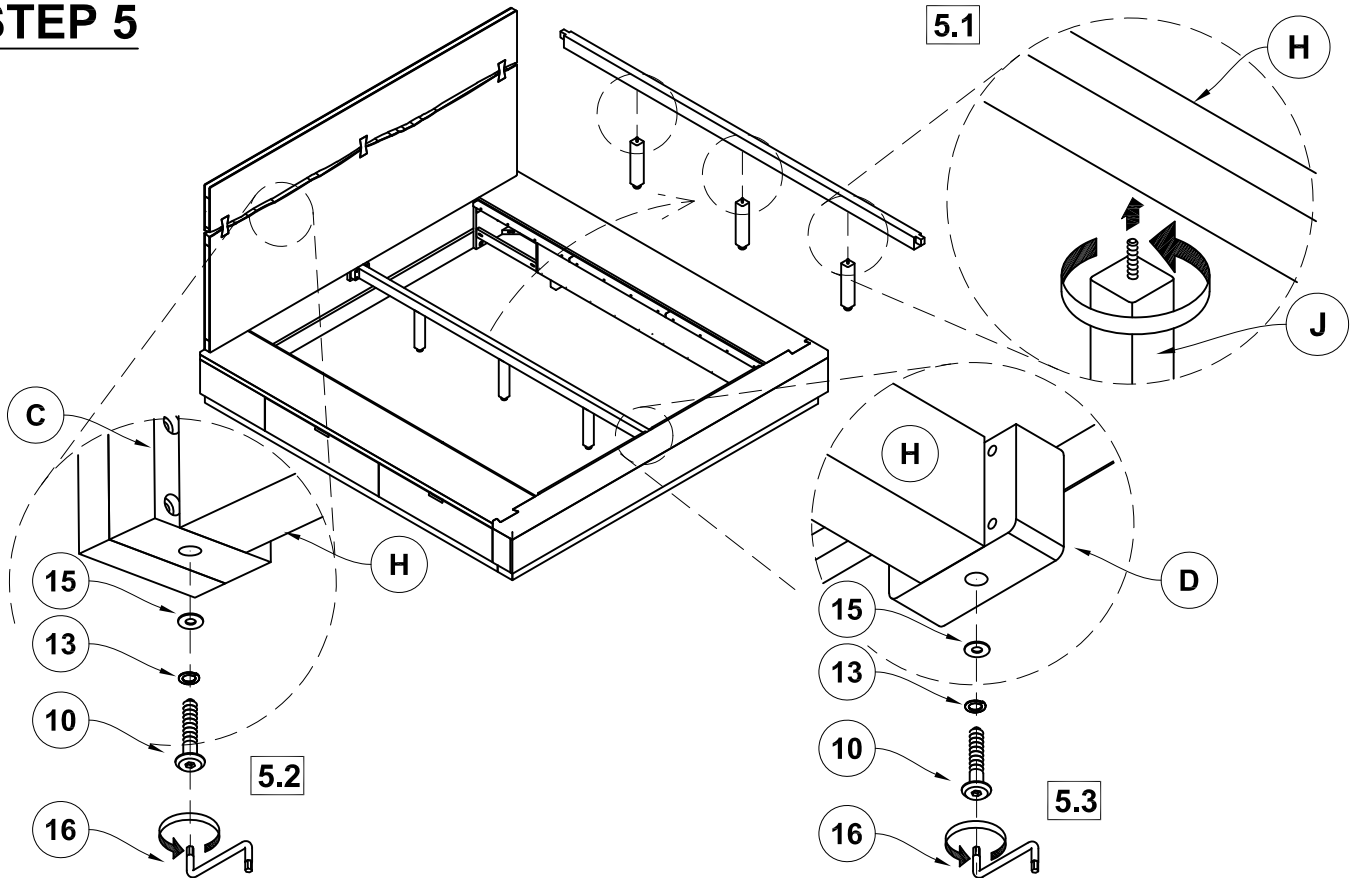

STEP 6

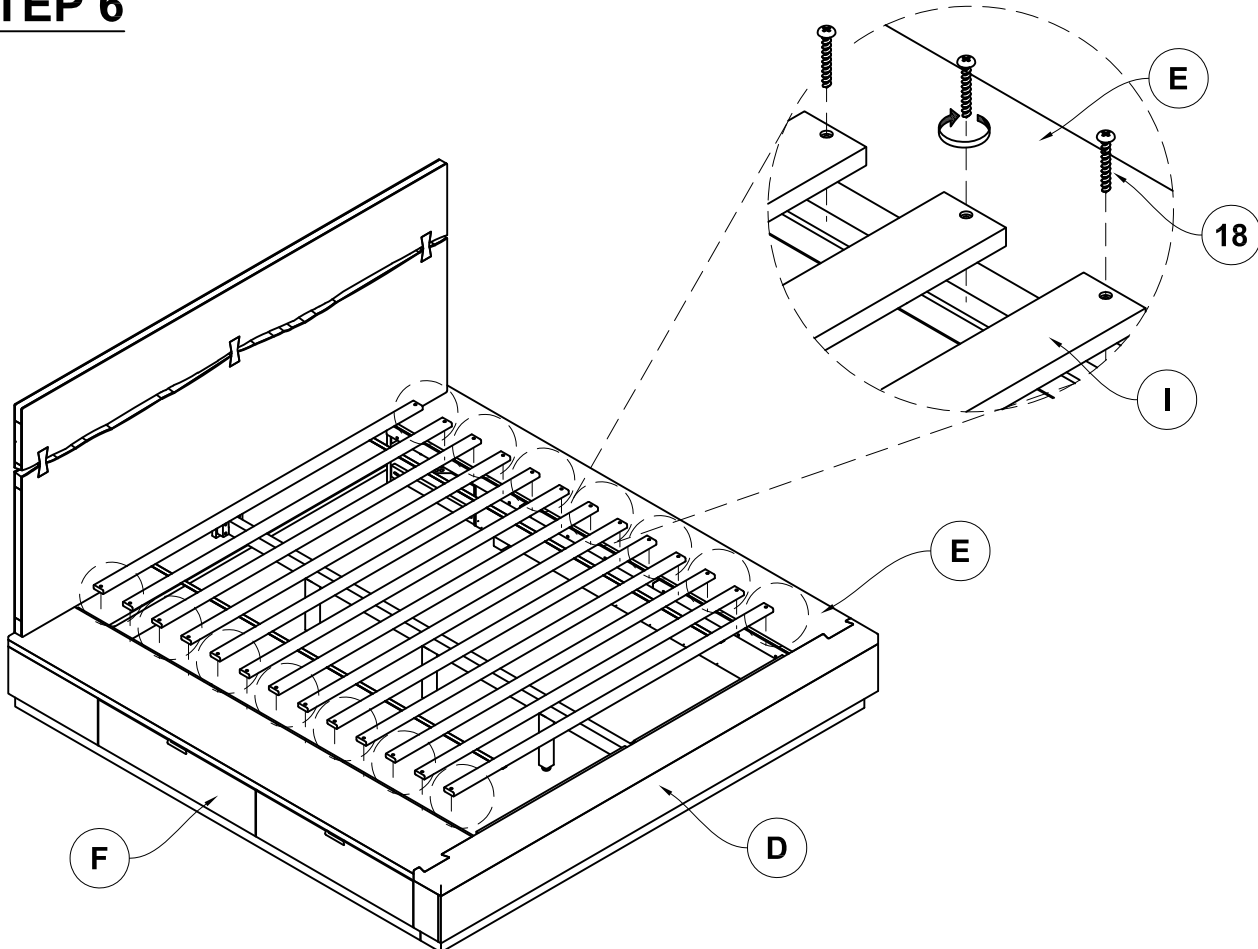

ITEM: 223250SKE (B1-B3)

ASSEMBLY INSTRUCTIONS

STEP 7

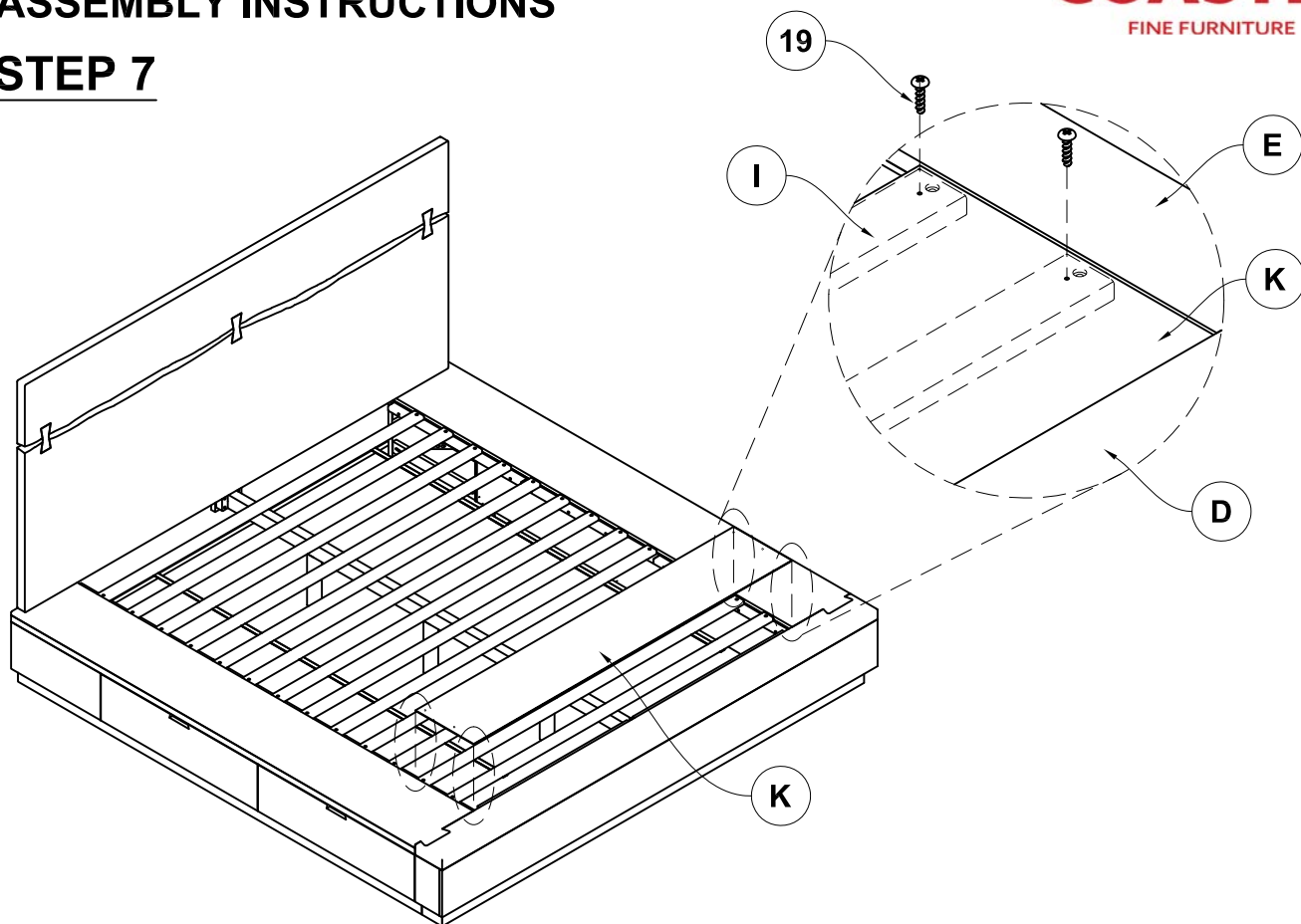

STEP 8 COMPLETE

