



ASSEMBLY INSTRUCTIONS
COASTER FINE FURNITURE



Fine Furniture for every stage of life

708167
END TABLE

REVISION 0 : 11/28/2018
REVISION 1 : 11/10/2022

PAGE 1 OF 4

COASTERFURNITURE.COM

ITEM: 708167



ASSEMBLY INSTRUCTIONS

ASSEMBLY TIPS:

1. Remove hardware from box and sort by size.
2. Please check to see that all hardware and parts are present prior to start of assembly.
3. Please follow attached instructions in the same sequence as numbered to assure fast & easy assembly.



WARNING!

1. Don't attempt to repair or modify parts that are broken or defective. Please contact the store immediately.
2. This product is for home use only and not intended for commercial establishments.

ASSEMBLY TIME 25 MINUTES

PARTS IDENTIFICATION

A TOP AND BOTTOM PANEL

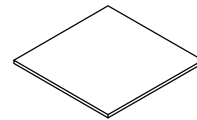

2PCS

B SIDE FRAME

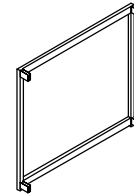

2PCS

C CROSSBAR

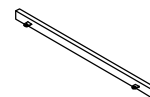

4PCS

HARDWARE IDENTIFICATION

1 SHORT BOLT
(1/4" x 12mm BLK)



16PCS

2 LONG BOLT
(4 x 12mm BLK)



8PCS

3 CAP
(16 x 16mm BLK)



4PCS

4 ALLEN WRENCH
(4mm)



1PC

ITEM: 708167 ASSEMBLY INSTRUCTIONS



STEP 1 Do not tighten until each step is completed or instructed.

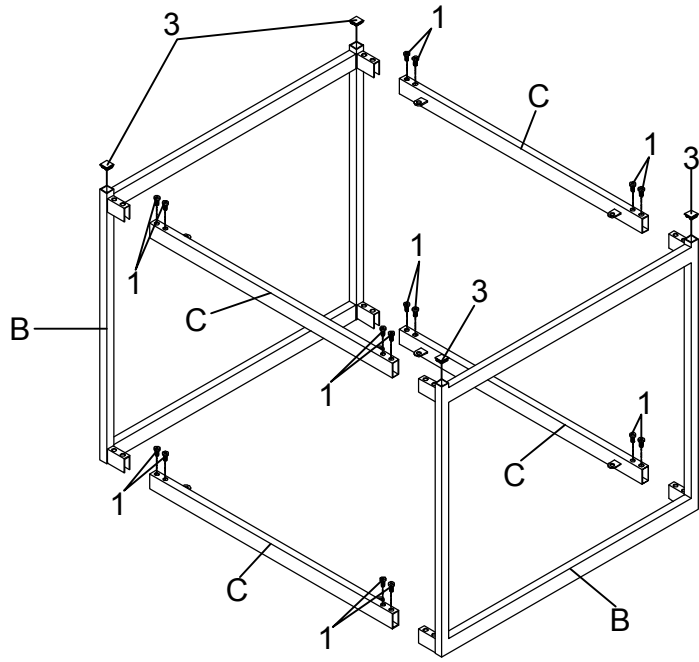

STEP 2

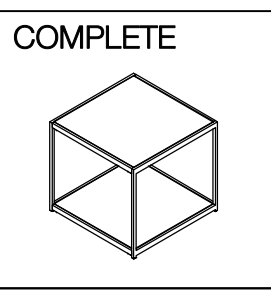
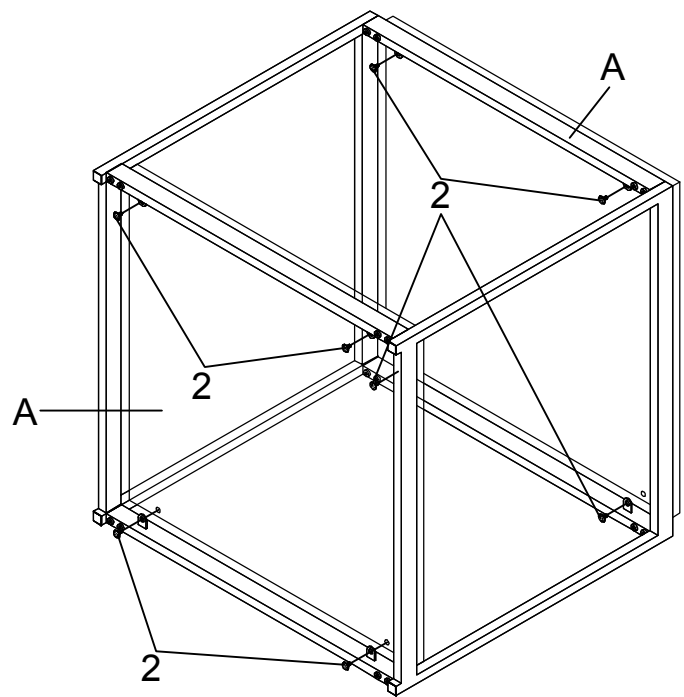

ITEM: 708167 ASSEMBLY INSTRUCTIONS



Product Size : 597 X 597 X 559 H (MM)
Product Size : 23.5" X 23.5" X 22"

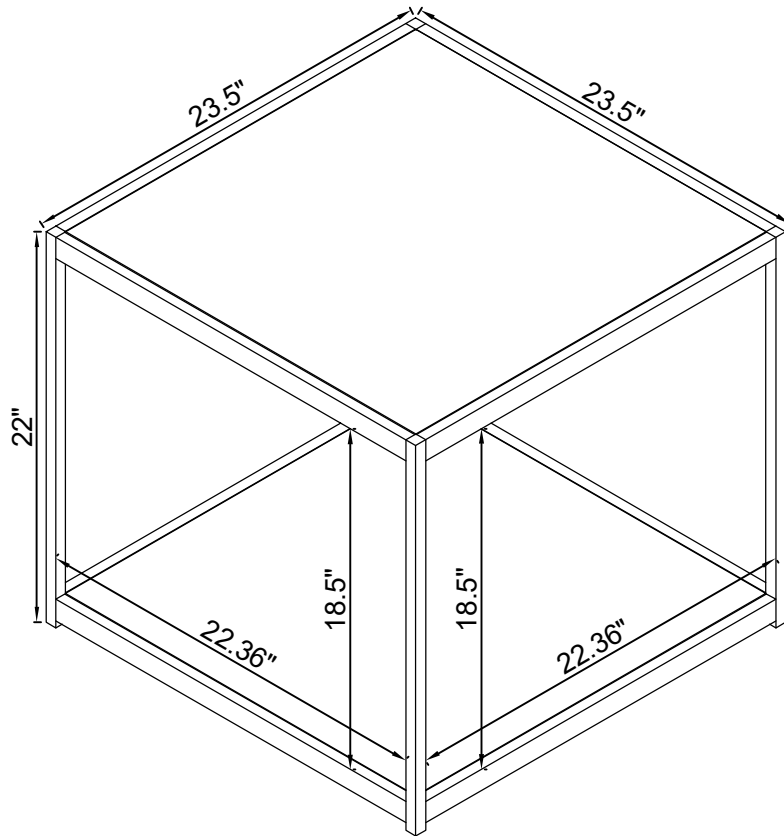

Note : Dimension tolerance $\pm 5\%$