

ASSEMBLY INSTRUCTIONS
COASTER FINE FURNITURE

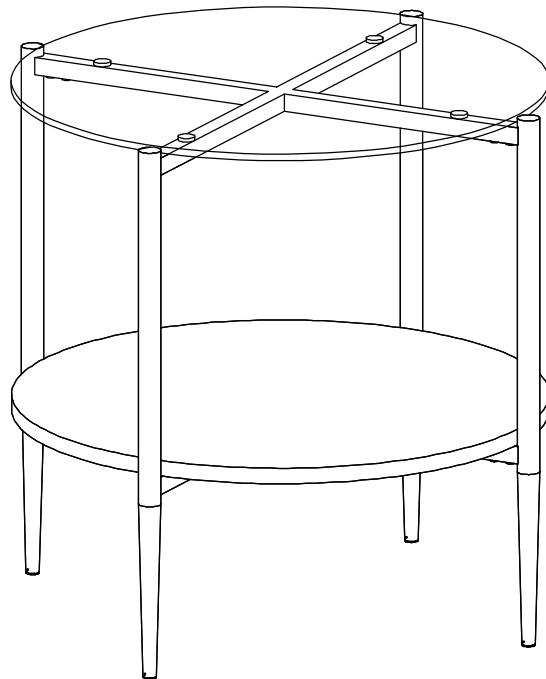

Fine Furniture for every stage of life

723277
END TABLE

REVISION 0 : 01/12/2021
REVISION 1 : 11/23/2022

ITEM:723277



ASSEMBLY INSTRUCTIONS

ASSEMBLY TIPS:

1. Remove hardware from box and sort by size.
2. Please check to see that all hardware and parts are present prior to start of assembly.
3. Please follow attached instructions in the same sequence as numbered to assure fast & easy assembly.



WARNING!

1. Don't attempt to repair or modify parts that are broken or defective. Please contact the store immediately.
2. This product is for home use only and not intended for commercial establishments.

ASSEMBLY TIME 35 MINUTES

PARTS IDENTIFICATION

A	GLASS		1PC
B	SHELF PANEL		1PC
C	FRAME		2PCS
D	LEG		4PCS

HARDWARE IDENTIFICATION

1	SHORT BOLT (1/4" x 12mm SR)		16PCS	4	CAP (Ø15mm BLK)		4PCS
2	MEDIUM BOLT (1/4" x 28mm SR)		4PCS	5	ALLEN KEY (4mm)		1PC
3	SUCTION CUP		4PCS				

ITEM:723277



ASSEMBLY INSTRUCTIONS

STEP 1 Do not tighten until each step is completed or instructed.

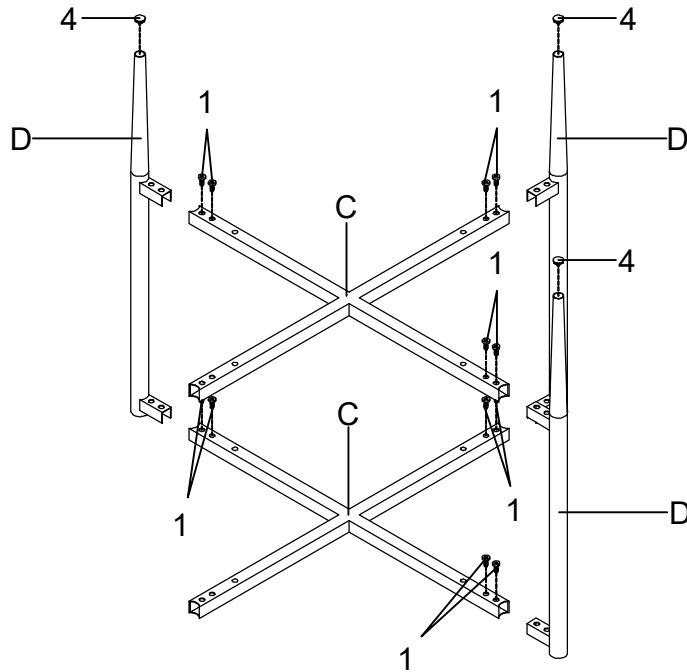

STEP 2

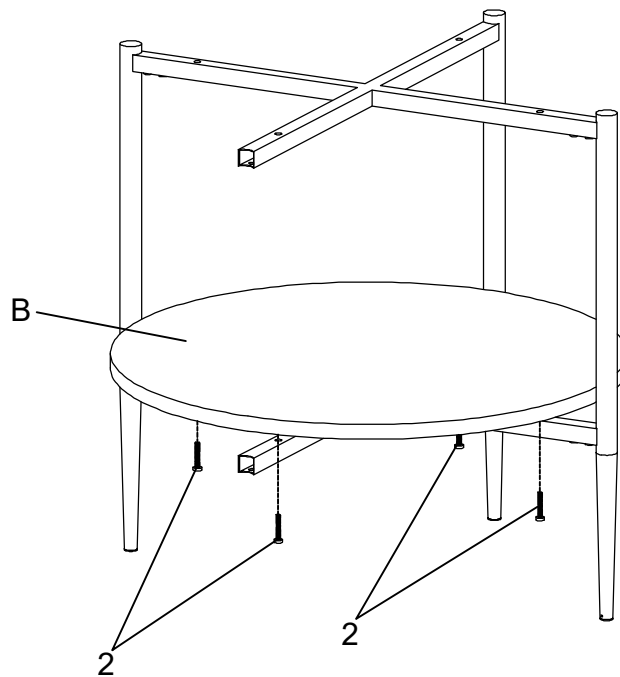

ITEM:723277

ASSEMBLY INSTRUCTIONS

STEP 3

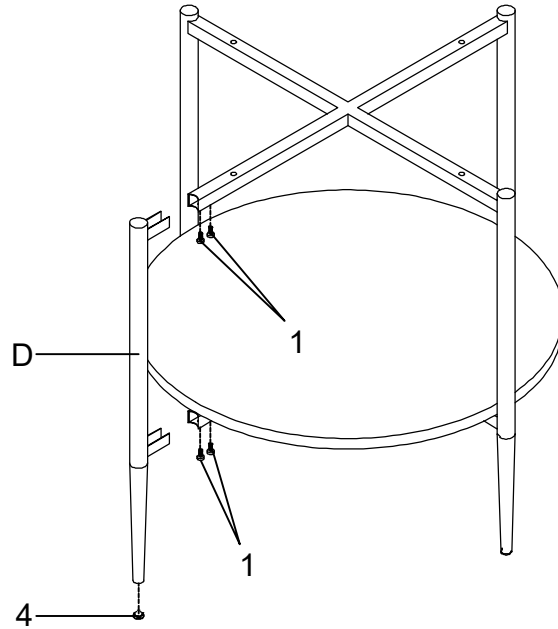

STEP 4

COMPLETE

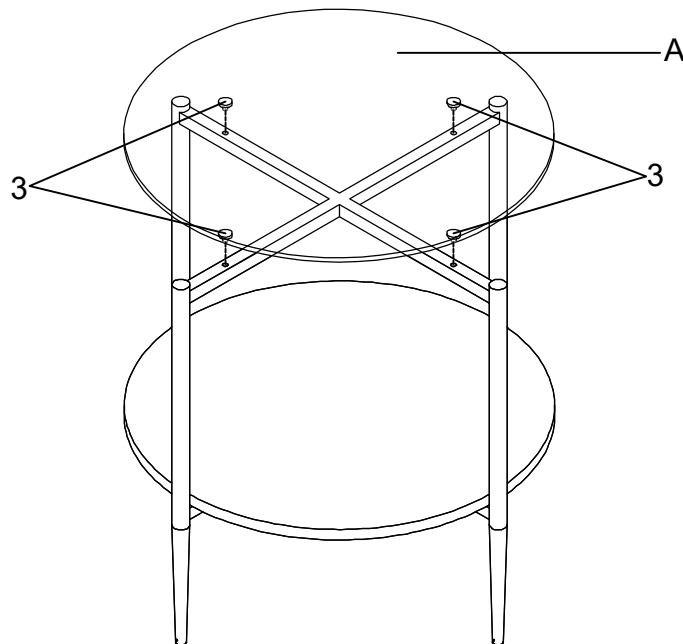

COMPLETE



ITEM:723277

ASSEMBLY INSTRUCTIONS



Product Size : 533 DIA X 610 H (MM)
Product Size : 21" DIA X 24"

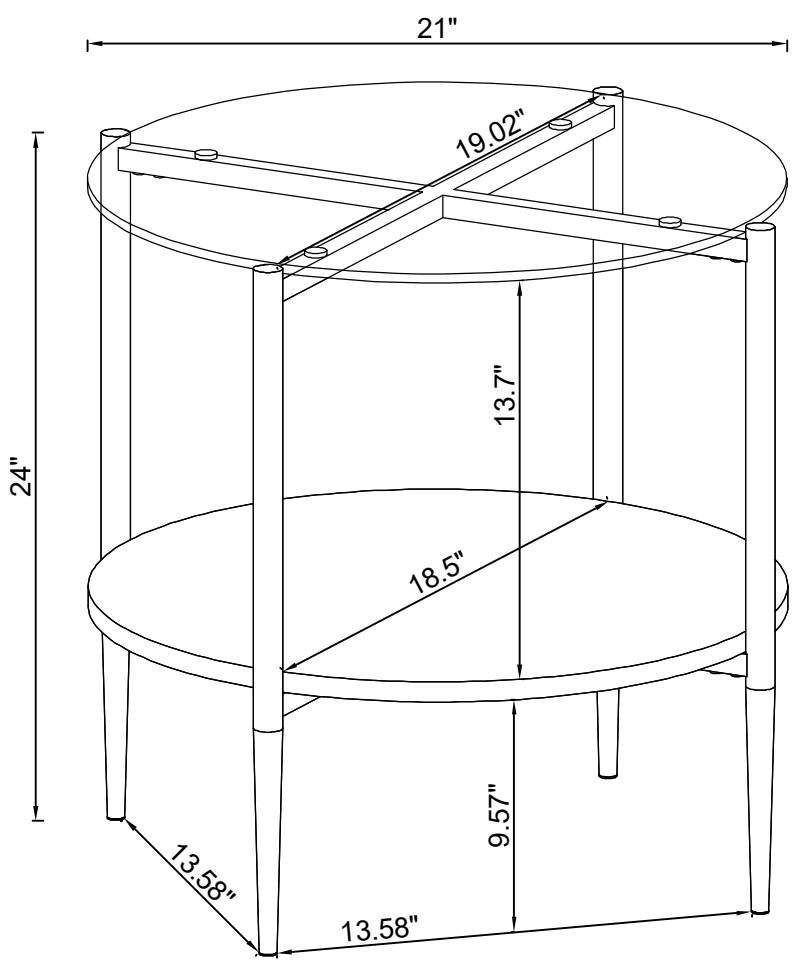

Note : Dimension tolerance $\pm 5\%$