

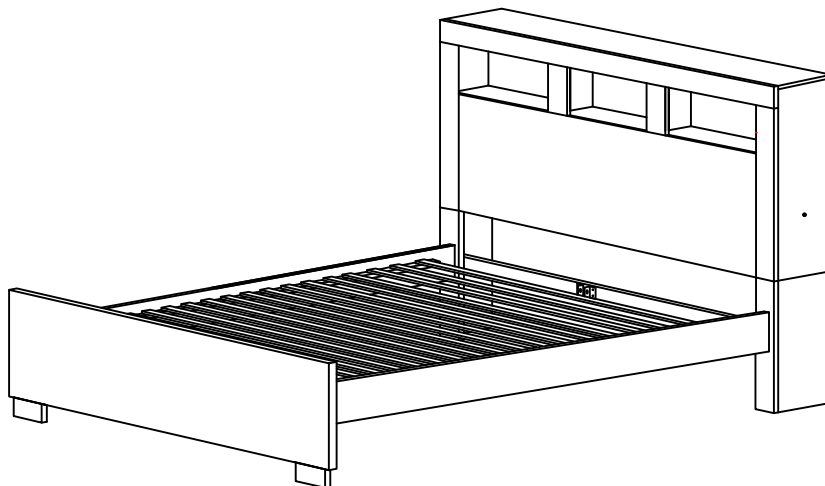

# ASSEMBLY INSTRUCTIONS COASTER FINE FURNITURE



*Fine Furniture for every stage of life*

## 200719KW (B1-B4) California King Bed

REVISION 0 : 07/03/2009  
REVISION 1 : 09/27/2012  
REVISION 2 : 02/09/2017  
REVISION 3 : 09/18/2018  
REVISION 4 : 12/02/2019  
REVISION 5 : 08/04/2020  
REVISION 6 : 12/02/2022

PAGE 1 OF 7

COASTERFURNITURE.COM

# ITEM:200719KW (B1-B4)



## ASSEMBLY INSTRUCTIONS

### ASSEMBLY TIPS:

1. Remove hardware from box and sort by size.
2. Please check to see that all hardware and parts are present prior to start of assembly.
3. Please follow attached instructions in the same sequence as numbered to assure fast & easy assembly.



### WARNING!

1. Don't attempt to repair or modify parts that are broken or defective. Please contact the store immediately.
2. This product is for home use only and not intended for commercial establishments.

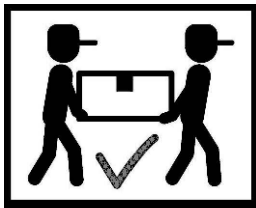





ASSEMBLY TIME

25 MINUTES

## PARTS IDENTIFICATION



### B1 ( BOX 1 )

|    |                       |  |     |
|----|-----------------------|--|-----|
| 1  | HEADBOARD PANEL       |   | 1PC |
| 2L | LEFT HEADBOARD LEG    |   | 1PC |
| 2R | RIGHT HEADBOARD LEG   |   | 1PC |
| 8  | HEADBOARD BOTTOM RAIL |  | 1PC |

### B2 ( BOX 2 )

|   |           |  |     |
|---|-----------|--|-----|
| 3 | FOOTBOARD |  | 1PC |
|---|-----------|--|-----|

### B3 ( BOX 3 )

|    |                |  |     |
|----|----------------|--|-----|
| 4L | LEFT BED RAIL  |  | 1PC |
| 4R | RIGHT BED RAIL |  | 1PC |
| 5  | CENTER RAIL    |  | 1PC |

# ITEM: 200719KW (B1-B4)



## ASSEMBLY INSTRUCTIONS

### ASSEMBLY TIPS:

1. Remove hardware from box and sort by size.
2. Please check to see that all hardware and parts are present prior to start of assembly.
3. Please follow attached instructions in the same sequence as numbered to assure fast & easy assembly.



### WARNING!

1. Don't attempt to repair or modify parts that are broken or defective. Please contact the store immediately.
2. This product is for home use only and not intended for commercial establishments.

6 CENTER RAIL SUPPORT  
WITH LEVELER



2PCS

### B4 (BOX 4)

7 ROLL SLAT (7PCS)



2SETS

HB 200719KW (B1)  
FROM BOX 1  
HEADBOARD COMPLETE

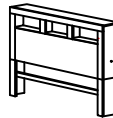

1PC

3 200719KW (B2)  
FROM BOX 2  
FOOTBOARD

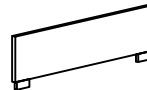

1PC

# ITEM: 200719KW (B1-B4)



## ASSEMBLY INSTRUCTIONS

### ASSEMBLY TIPS:

1. Remove hardware from box and sort by size.
2. Please check to see that all hardware and parts are present prior to start of assembly.
3. Please follow attached instructions in the same sequence as numbered to assure fast & easy assembly.







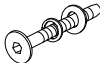

### WARNING!

1. Don't attempt to repair or modify parts that are broken or defective. Please contact the store immediately.
2. This product is for home use only and not intended for commercial establishments.

## HARDWARE IDENTIFICATION

### Z-B1 (BOX 1) - HARDWARE PACK IS LOCATED IN 200719KW(B1)

|   |   |   |       |
|---|---|---|-------|
| A | <b>ALLEN WRENCH</b><br>(M4 x 110mm - BLK)         |    | 1PC   |
| B | <b>BOLT</b><br>(M6 x 50mm - BLK)                  |   | 14PCS |
| C | <b>LONG FLAT HEAD SCREW</b><br>(M4 x 32mm- BLK)   |  | 28PCS |
| D | <b>SHORT FLAT HEAD SCREW</b><br>(M4 x 20mm - BLK) |  | 8PCS  |
| E | <b>WRENCH</b><br>(2 x 24.5 x 85 - RBW)            |  | 1PC   |
| F | <b>HEX NUT</b><br>(M6 - RBW)                      |  | 2PCS  |
| G | <b>U BRACKET</b><br>(26 x 63 x 70mm - RBW)        |  | 2PCS  |

### NOTE:

Phillips head screw driver is required in the assembly process; however, manufacturer does not provide this item.

# ITEM: 200719KW (B1-B4)



## ASSEMBLY INSTRUCTIONS

### STEP 1

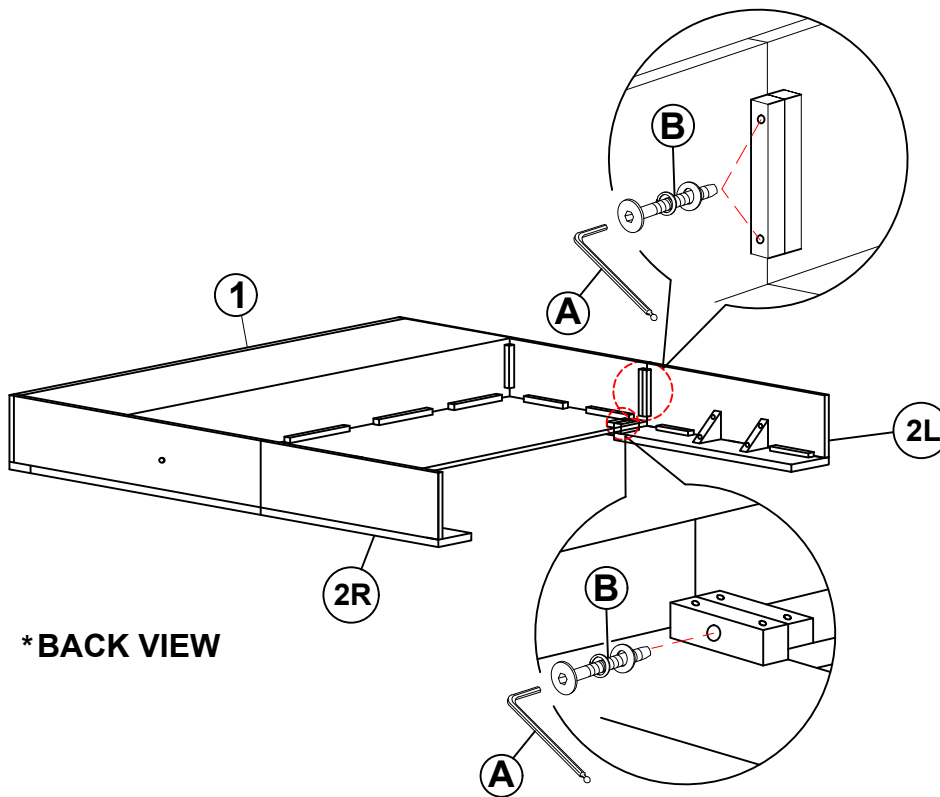

\*BACK VIEW

### STEP 2

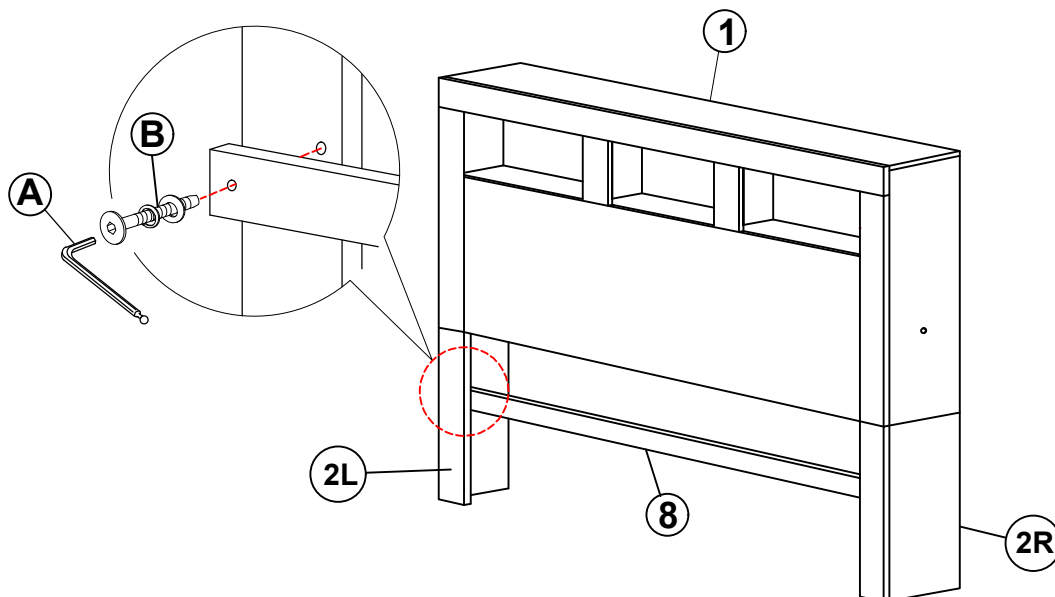

# ITEM: 200719KW (B1-B4)



## ASSEMBLY INSTRUCTIONS STEP 3

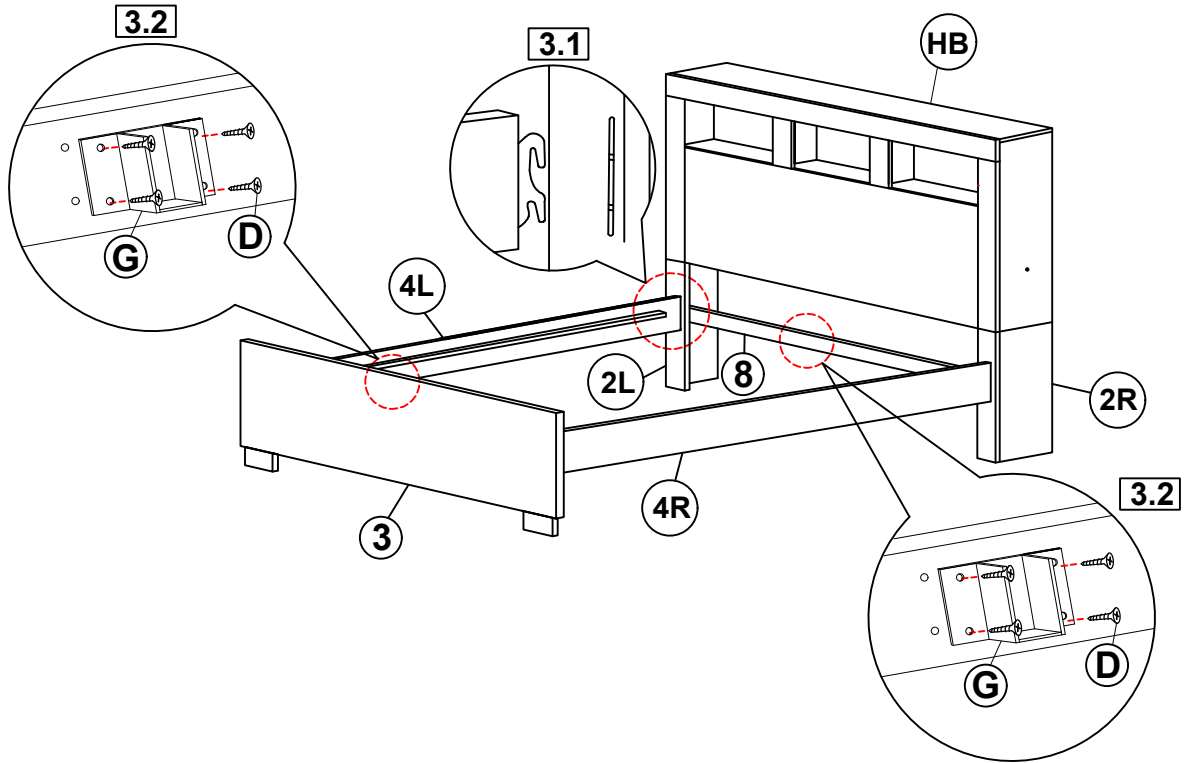

## STEP 4

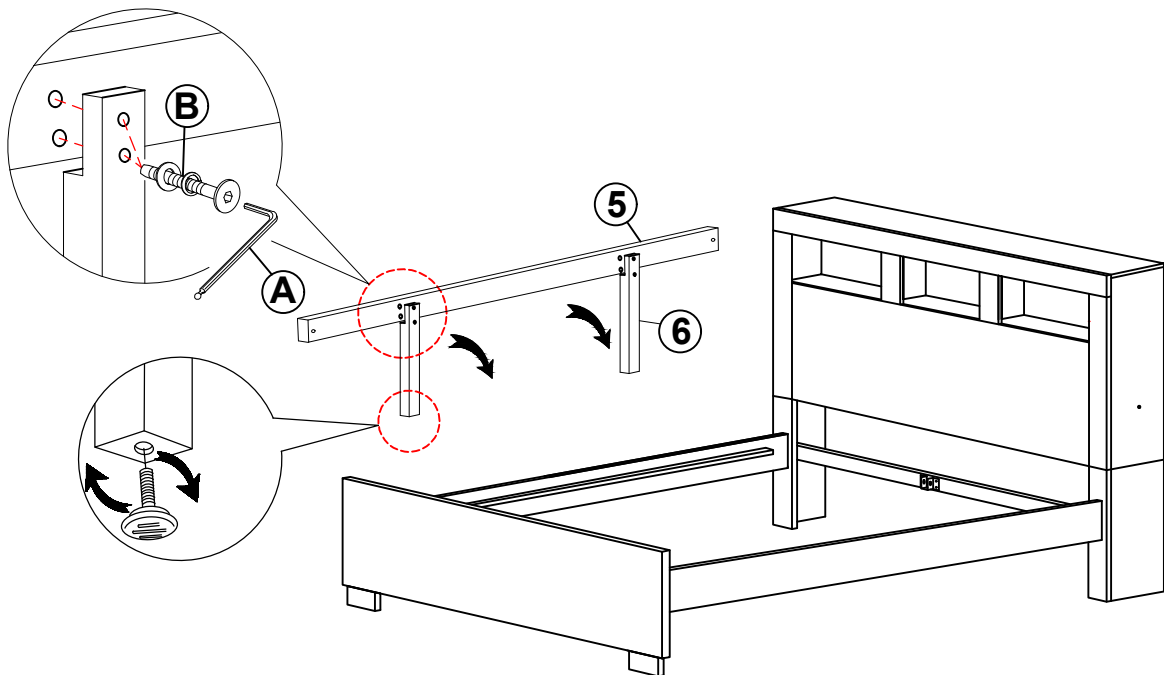

# ITEM: 200719KW (B1-B4)



## ASSEMBLY INSTRUCTIONS STEP 5

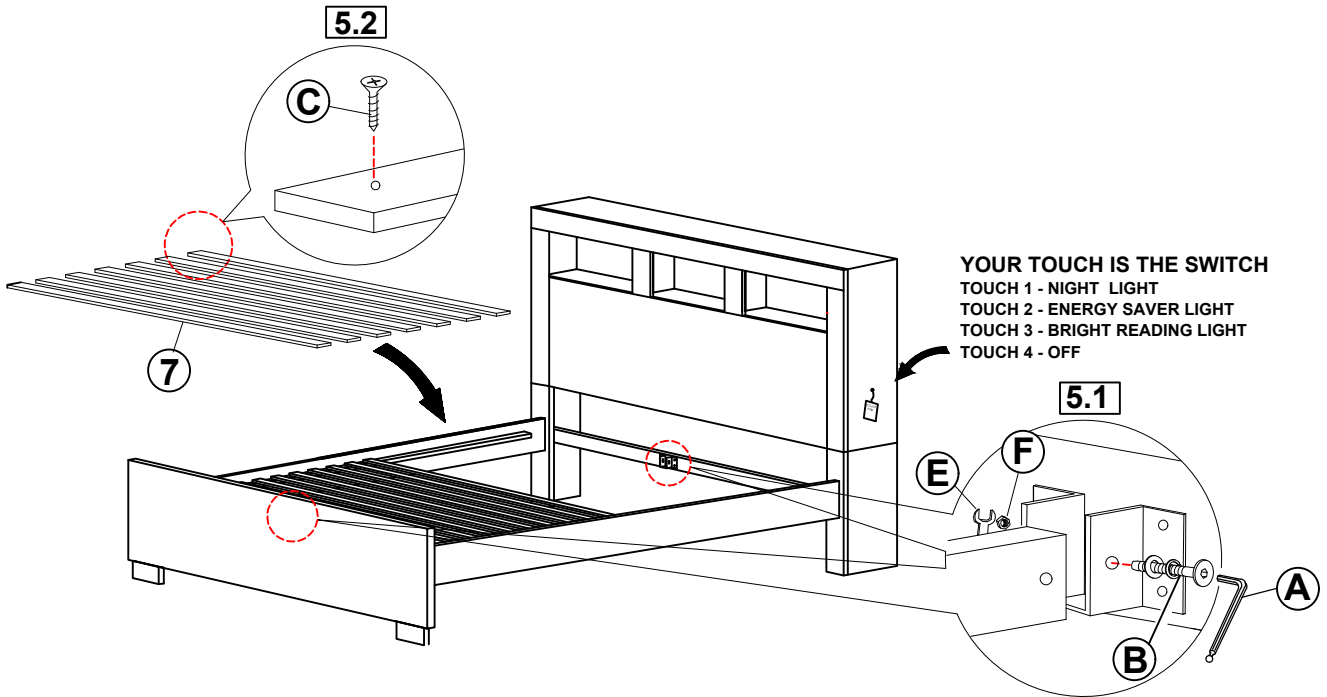

## STEP 6 COMPLETE

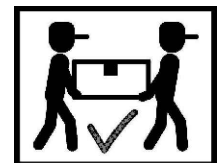
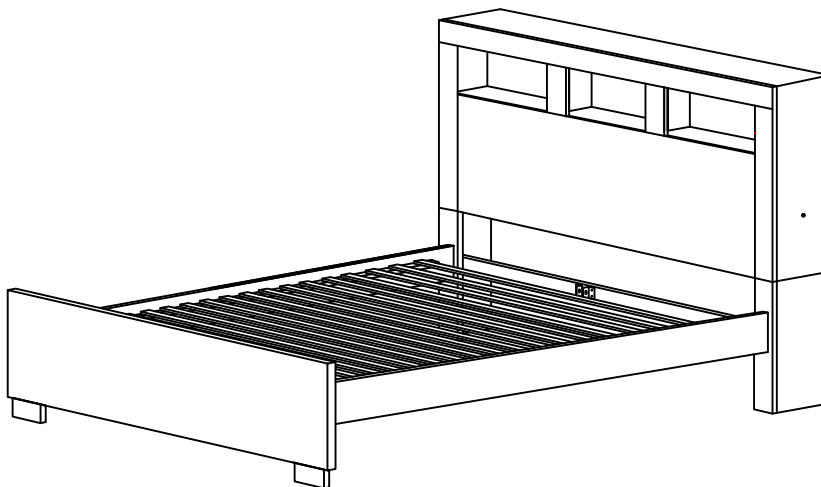

# ITEM: 200719KW (B1-B4)



Inner Size : 72.00"W x 85.00"D

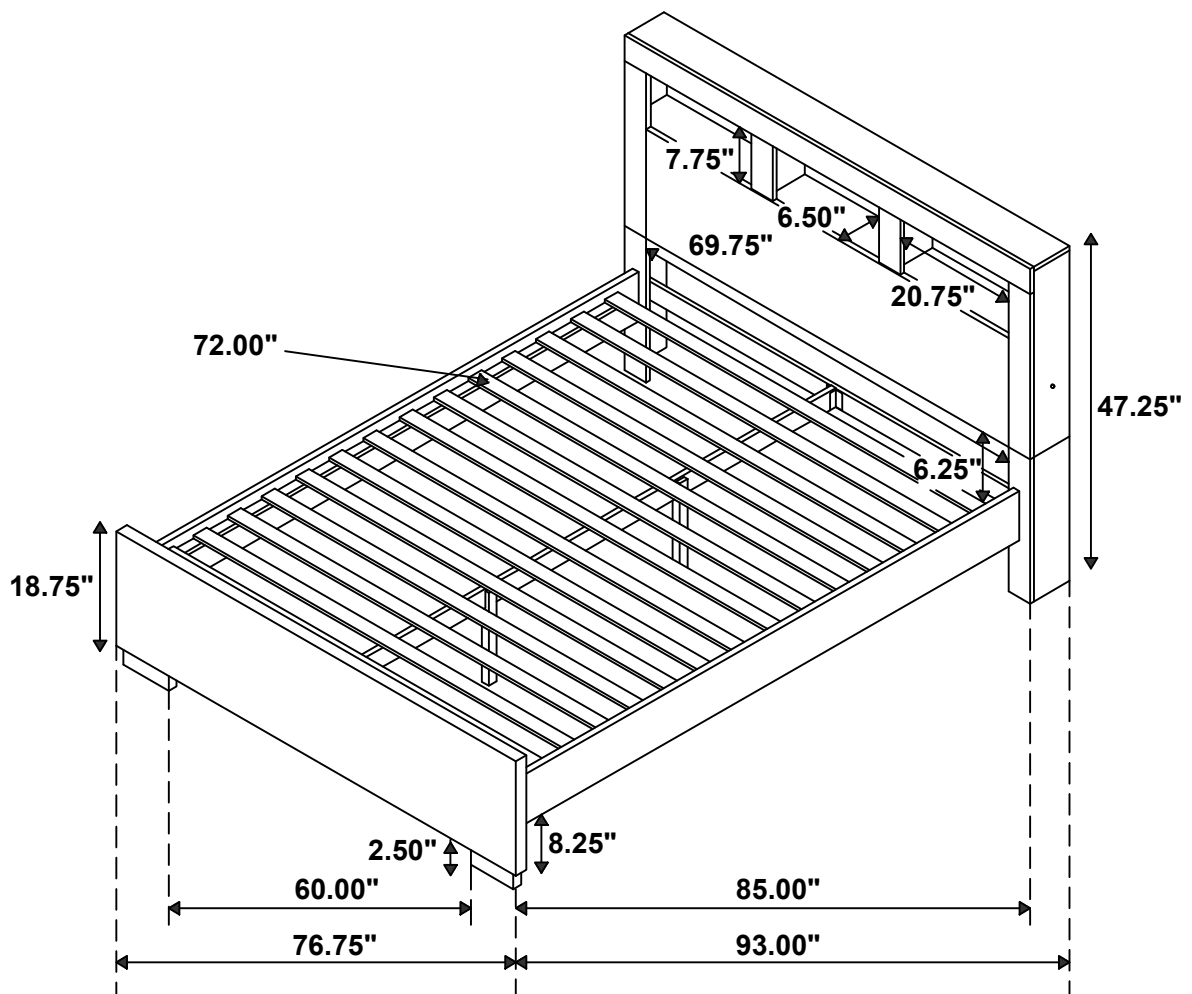

Note: Dimension tolerance  $\pm 5\%$