

ASSEMBLY INSTRUCTIONS
COASTER FINE FURNITURE



Fine Furniture for every stage of life

300635
Daybed

ITEM: 300635



ASSEMBLY INSTRUCTIONS

ASSEMBLY TIPS:

1. Remove hardware from box and sort by size.
2. Please check to see that all hardware and parts are present prior to start of assembly.
3. Please follow attached instructions in the same sequence as numbered to assure fast & easy assembly.



WARNING!

1. Don't attempt to repair or modify parts that are broken or defective. Please contact the store immediately.
2. This product is for home use only and not intended for commercial establishments.



ASSEMBLY TIME

35 MINUTES

PARTS IDENTIFICATION

A	BACK PANEL		1PC	D	FRONT RAIL		1PC
B	LEFT SIDE PANEL		1PC	E	LEG		4PCS
C	RIGHT SIDE PANEL		1PC	F	ROLL SLAT (7PCS)		2SETS

HARDWARE IDENTIFICATION

1	SHORT BOLT (M8 x 20MM - RBW)		8PCS	5	FLAT WASHER (15/64" x 19 Ø - RBW)		2PCS
2	MEDIUM BOLT (M6 x 25MM - RBW)		8PCS	6	FLAT HEAD SCREW (M4 x 32MM - RBW)		8PCS
3	LONG BOLT (M6 x 50MM - RBW)		2PCS	7	SMALL ALLEN WRENCH (M4 x 65MM - BLK)		1PC
4	LOCK WASHER (15/64" x 12 Ø - RBW)		10PCS	8	BIG ALLEN WRENCH (M5 x 65MM - BLK)		1PC

NOTE:

Phillips head screw driver is required in the assembly process; however, manufacturer does not provided this item.

ITEM: **300635**

ASSEMBLY INSTRUCTIONS

STEP 1

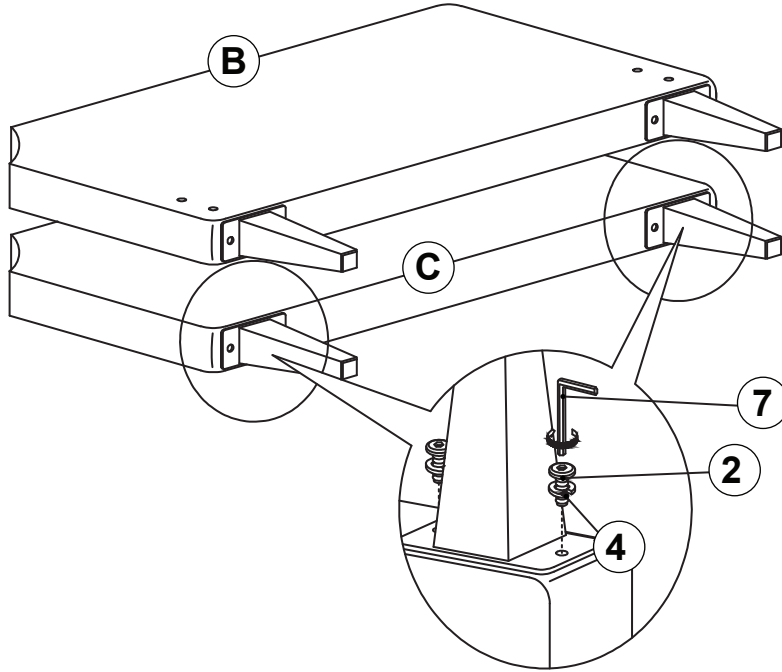

STEP 2

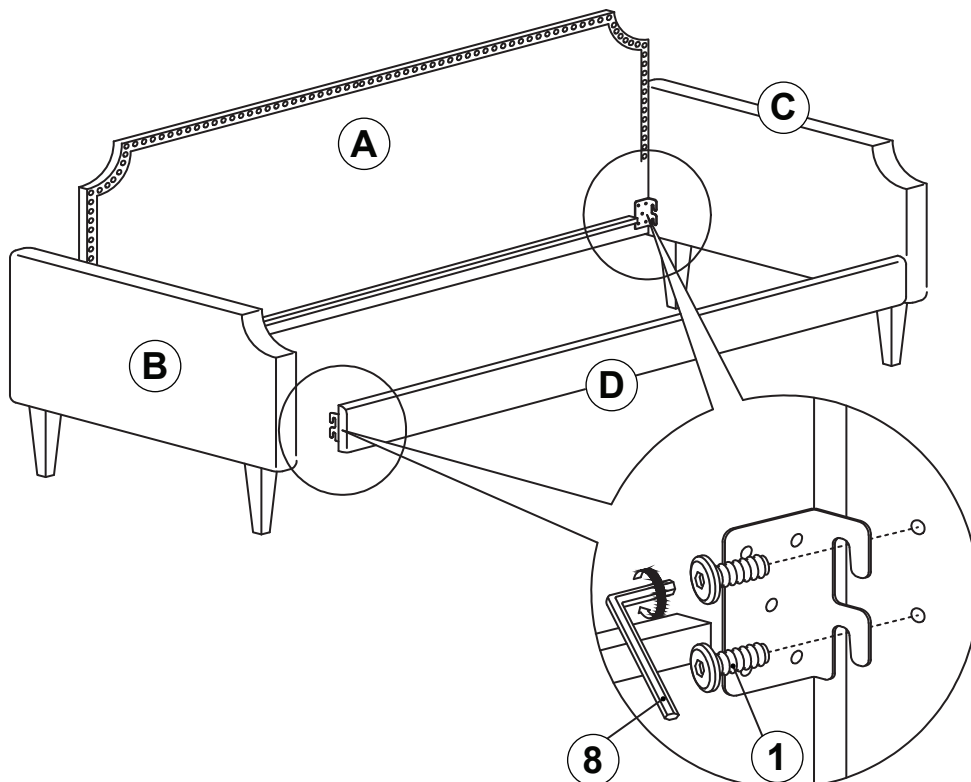

ITEM: **300635**

ASSEMBLY INSTRUCTIONS

STEP 3

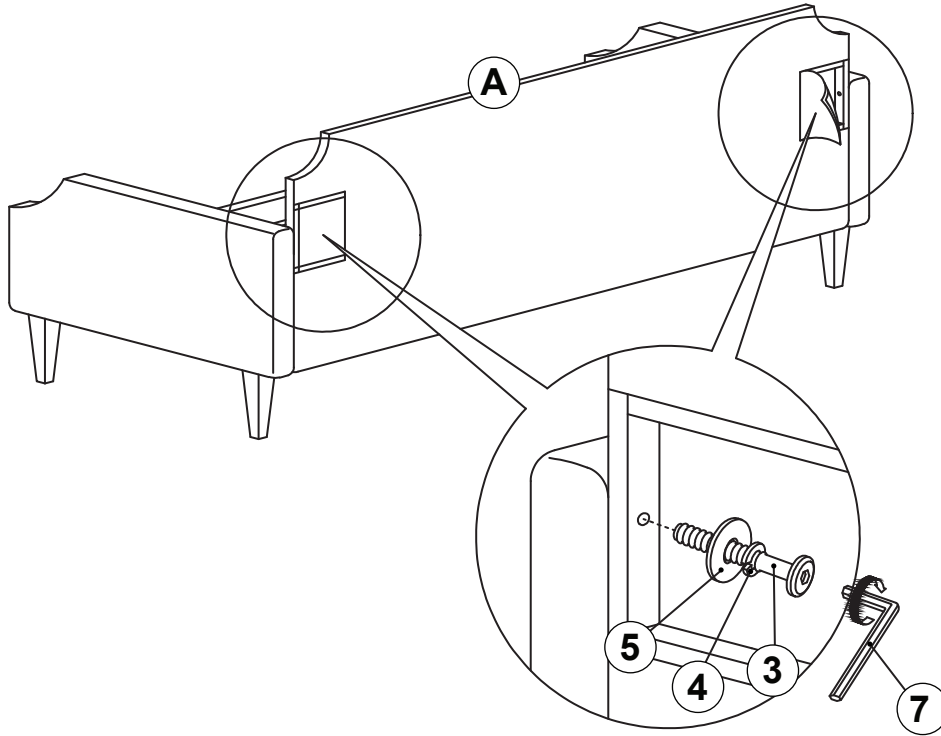

STEP 4

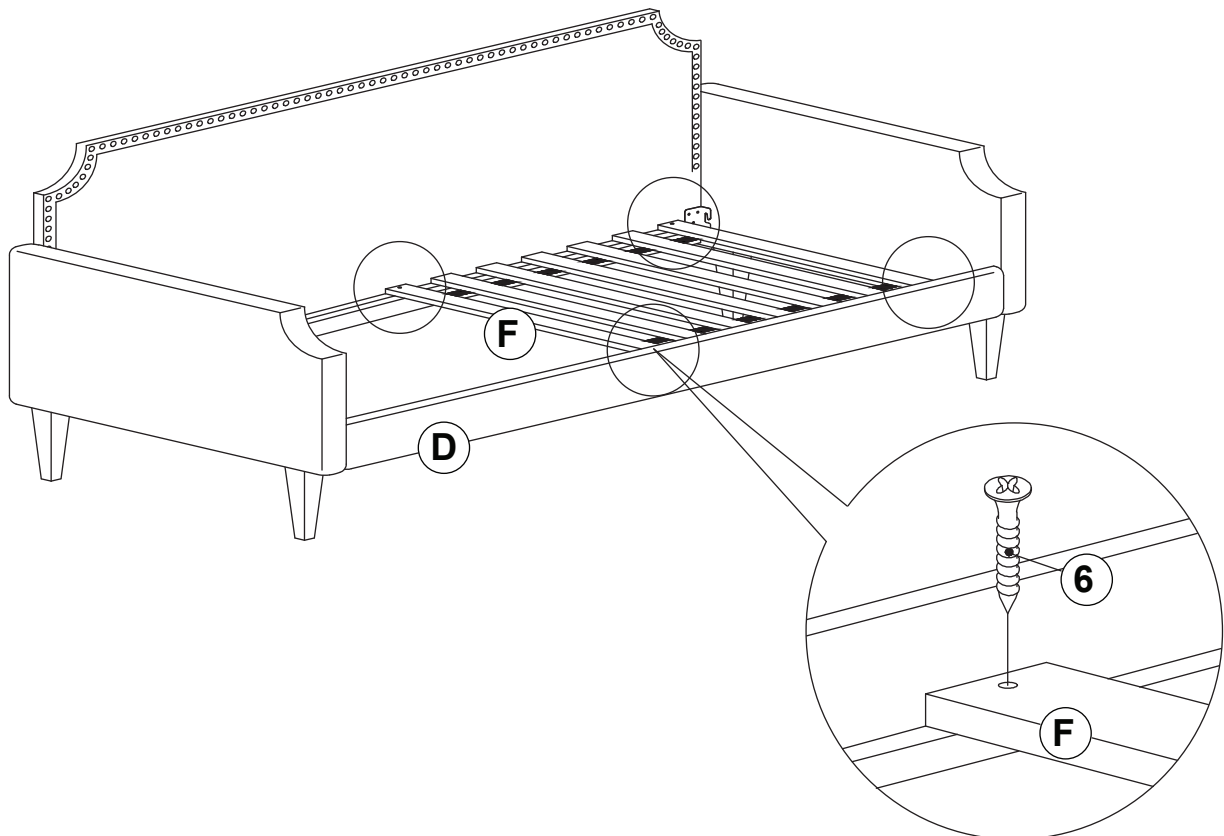

ITEM: **300635**



ASSEMBLY INSTRUCTIONS

STEP 5

COMPLETE

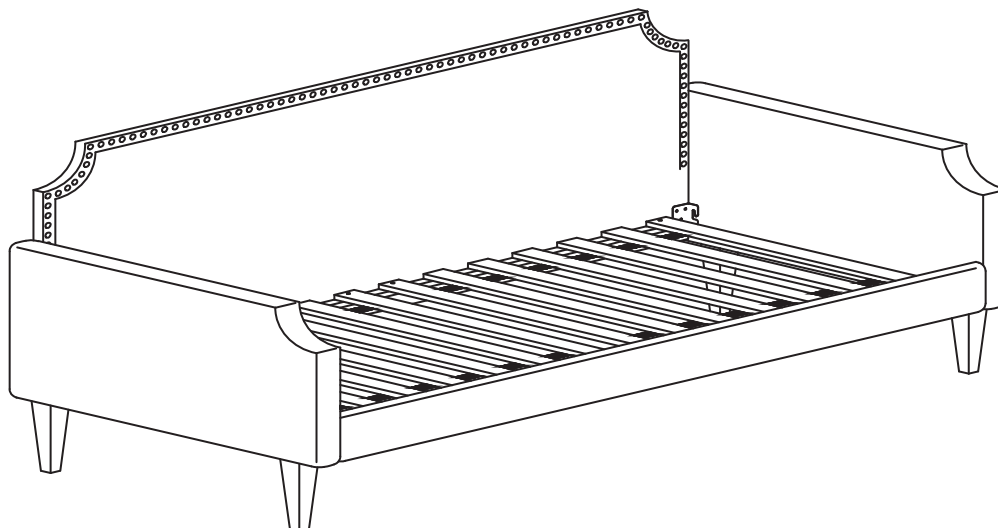

ITEM: **300635**



Inner Size: 39.50"W x 76.25"D

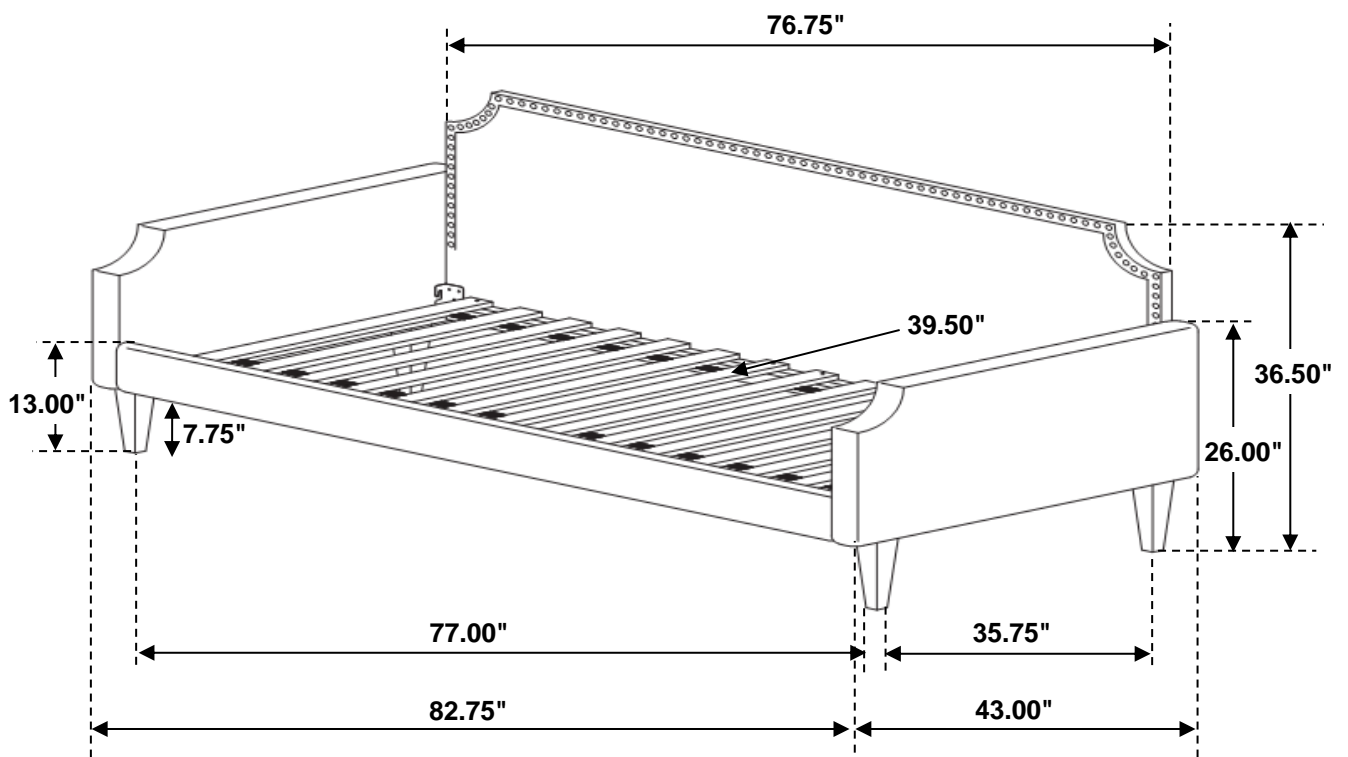

Note : Dimension tolerance $\pm 5\%$