

ASSEMBLY INSTRUCTIONS
COASTER FINE FURNITURE



Fine Furniture for every stage of life

115158 (B1&B2)
Counter Height Table

ASSEMBLY INSTRUCTIONS

ASSEMBLY TIPS:

1. Remove hardware from box and sort by size.
2. Please check to see that all hardware and parts are present prior to start of assembly.
3. Please follow attached instructions in the same sequence as numbered to assure fast & easy assembly.



WARNING!

1. Don't attempt to repair or modify parts that are broken or defective. Please contact the store immediately.
2. This product is for home use only and not intended for commercial establishments.



ASSEMBLY TIME

15 MINUTES

PARTS IDENTIFICATION

B1 (BOX 1)

A	TOP		1PC
---	-----	--	-----

B2 (BOX 2)

B	LEG		4PCS
---	-----	--	------

C	DRAWER BOX		1PC
---	------------	--	-----

HARDWARE IDENTIFICATION

Z-B2 (BOX 2) - HARDWARE PACK IS LOCATED IN 115158(B2)

1	SHORT BOLT (JCBB M8 X 60mm)		4PCS
---	--------------------------------	--	------

2	LONG BOLT (JCBB M8 X 80mm)		8PCS
---	-------------------------------	--	------

3	ALLEN WRENCH (M5 - BLK)		1PC
---	----------------------------	--	-----

4	LOCK WASHER (M8 - BLK)		12PCS
---	---------------------------	---	-------

5	FLAT WASHER (M8 - BLK)		12PCS
---	---------------------------	---	-------

ITEM: 115158 (B1&B2)



ASSEMBLY INSTRUCTIONS
STEP 1

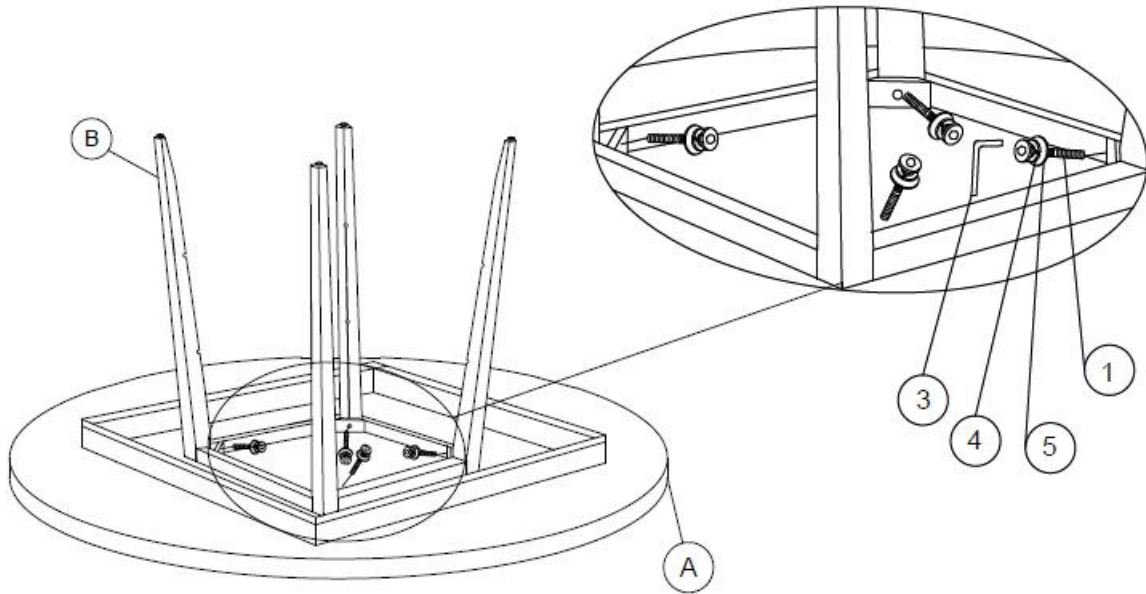

STEP 2

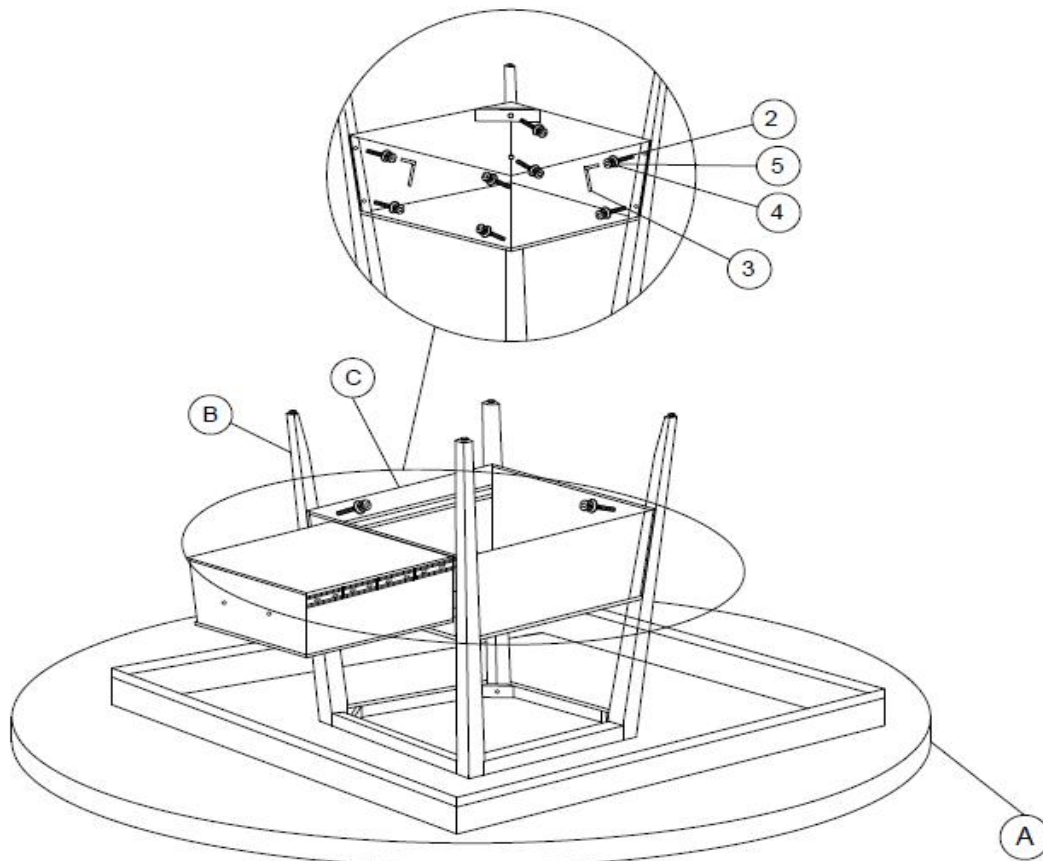

ITEM: **115158(B1&B2)**



ASSEMBLY INSTRUCTIONS

STEP 3

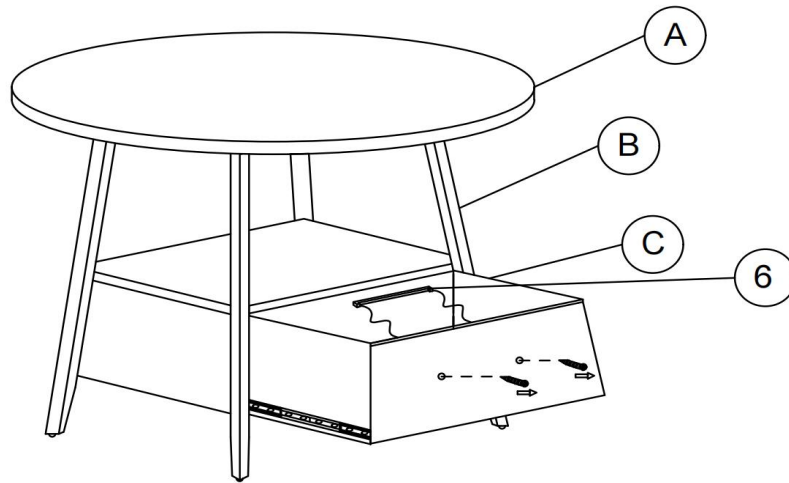

STEP 4

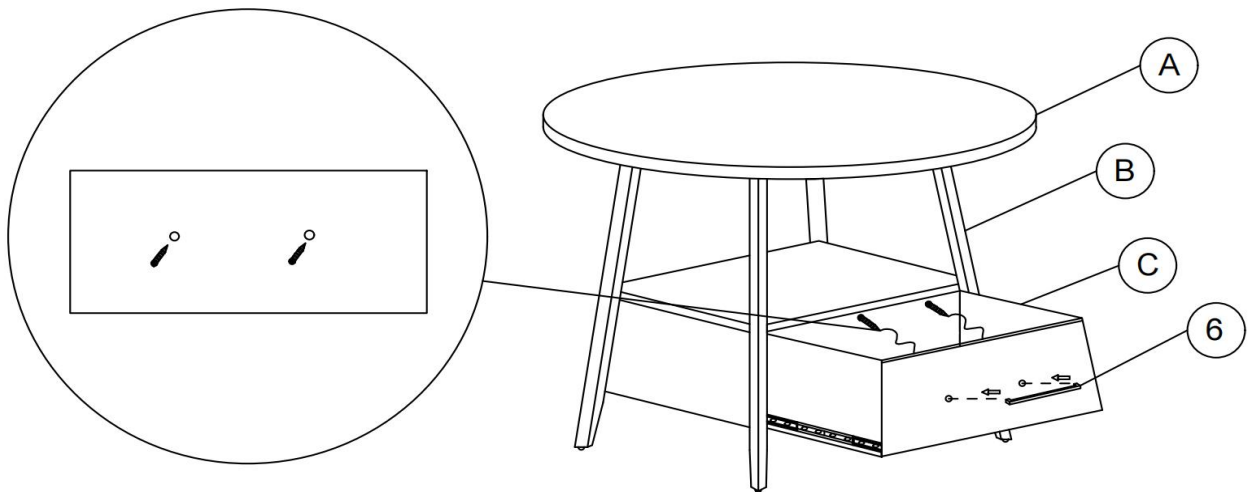

STEP 5
COMPLETE

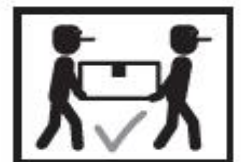

ITEM: **115158(B1&B2)**



Inner Size of Drawer : 19.50"W X 14.25"D X 5.50"H X 0.50"T

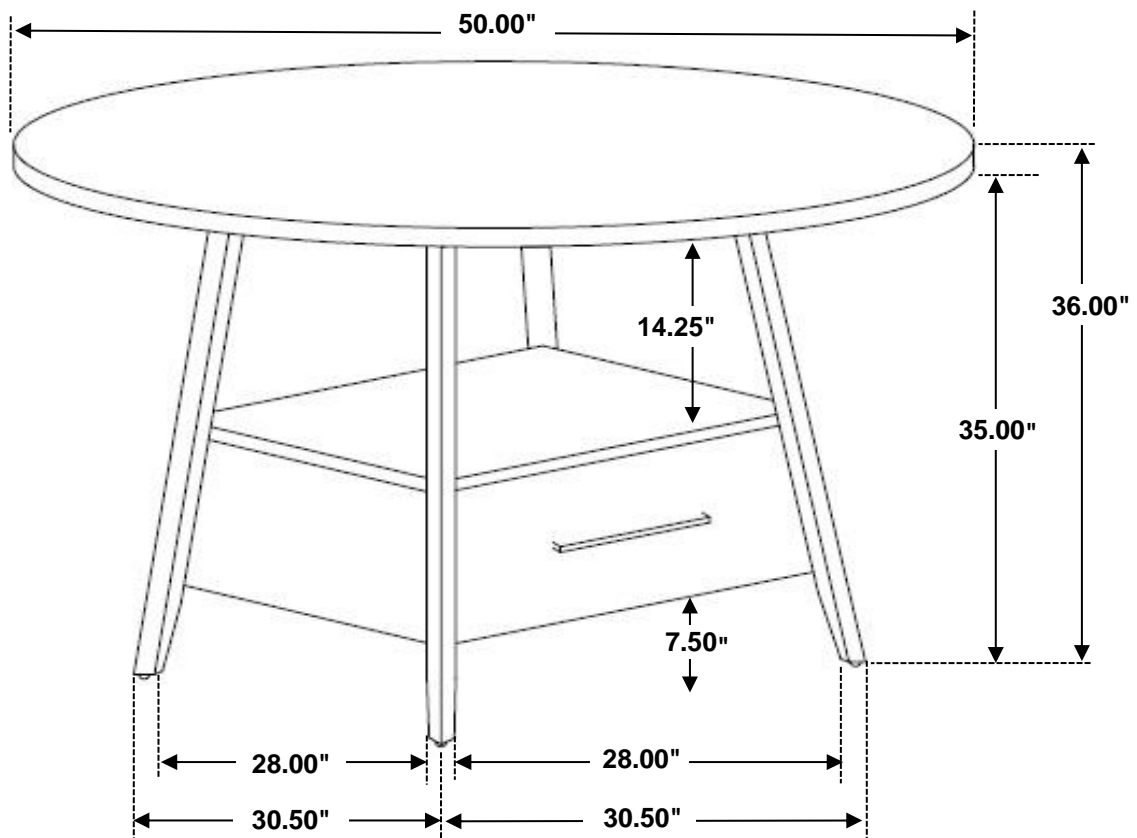

Note: Dimension tolerance $\pm 5\%$