

ASSEMBLY INSTRUCTIONS
COASTER FINE FURNITURE

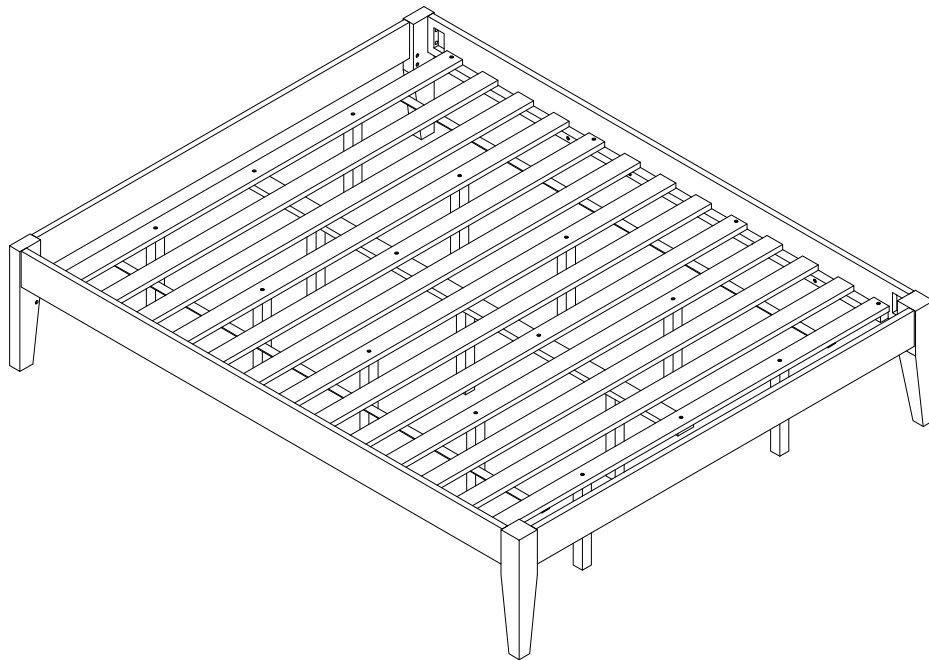

Fine Furniture for every stage of life

306129KW (B1&B2)
California King Platform Bed

ITEM: 306129KW (B1&B2)



ASSEMBLY INSTRUCTIONS

ASSEMBLY TIPS:

1. Remove hardware from box and sort by size.
2. Please check to see that all hardware and parts are present prior to start of assembly.
3. Please follow attached instructions in the same sequence as numbered to assure fast & easy assembly.



WARNING!

1. Don't attempt to repair or modify parts that are broken or defective. Please contact the store immediately.
2. This product is for home use only and not intended for commercial establishments.

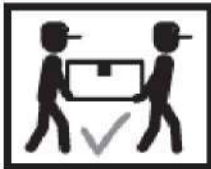





ASSEMBLY TIME

15 MINUTES

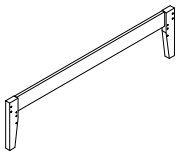
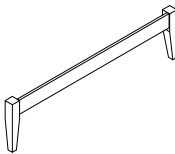
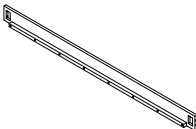

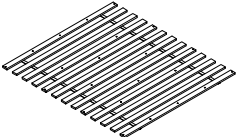



PARTS IDENTIFICATION

B1 (BOX 1)

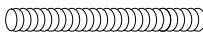
A	HEADBOARD		1PC	B	FOOTBOARD		1PC
<h3><u>B2 (BOX 2)</u></h3>							
C	BED RAIL		2PCS	F	BED SLAT SUPPORT WITH LEVELER		10PCS
D	ROLL SLAT (13PCS)		1SET	G	CENTER RAIL SUPPORT WITH LEVELER		3PCS
E	CENTER RAIL		1PC				

HARDWARE IDENTIFICATION

Z-B2 (BOX2) - HARDWARE PACK IS LOCATED IN 306128KW (B2)

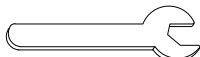
1	THREADED BOLT (5/16 x 90mm - RBW)		8PCS	5	BOLT (1/4 x 35mm Φ 12L4 - RBW)		13PCS
2	HEX NUT (5/16 x 12mm - RBW)		8PCS	6	ALLEN WRENCH (4 x 58MM - RBW)		1PC
3	FLAT WASHER (8 x 16 x 1.5mm - RBW)		8PCS	7	FLAT HEAD SCREW (4 x 30mm - RBW)		12PCS
4	WRENCH (12mm - RBW)		1PC				

NOTE:

Phillips head screw driver is required in the assembly process; however, manufacturer does not provide this item.

ITEM: 306129KW (B1&B2)

ASSEMBLY INSTRUCTIONS

STEP 1

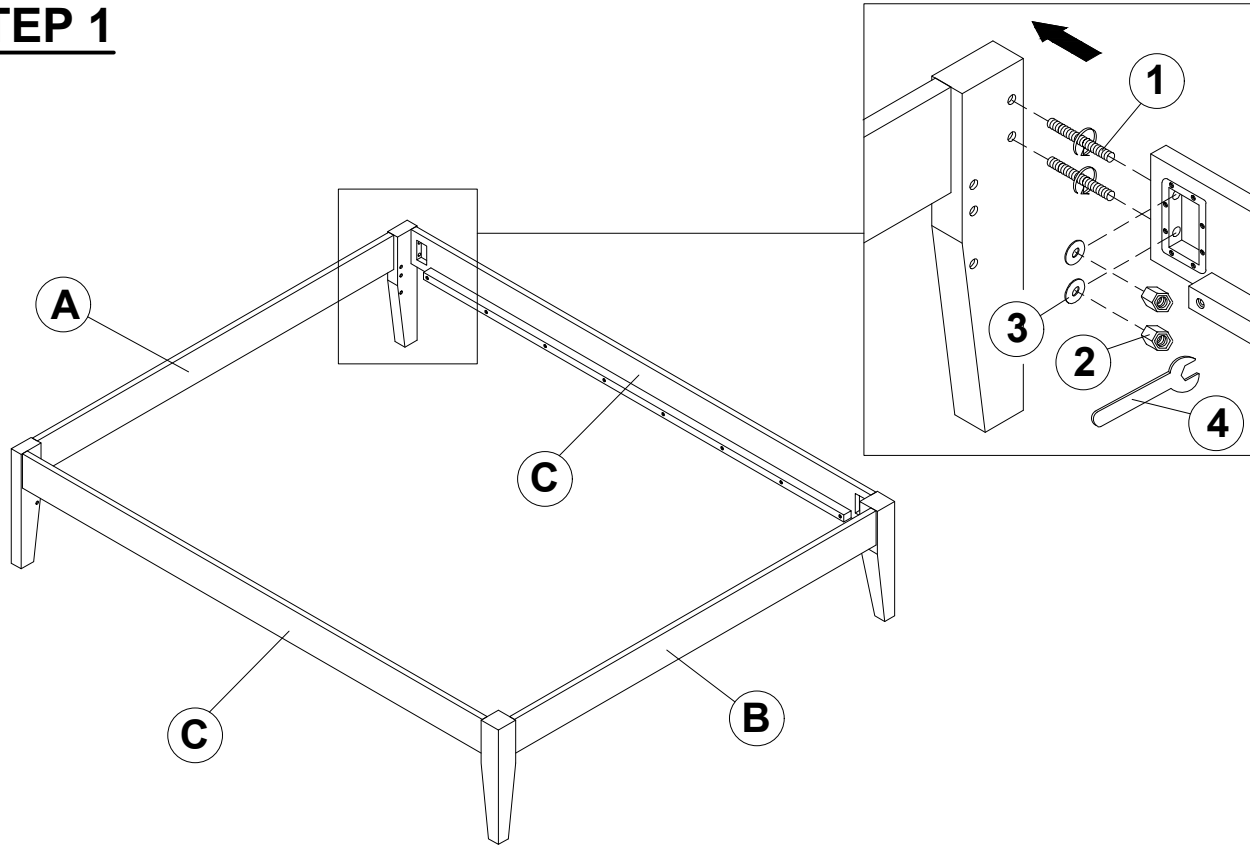

STEP 2

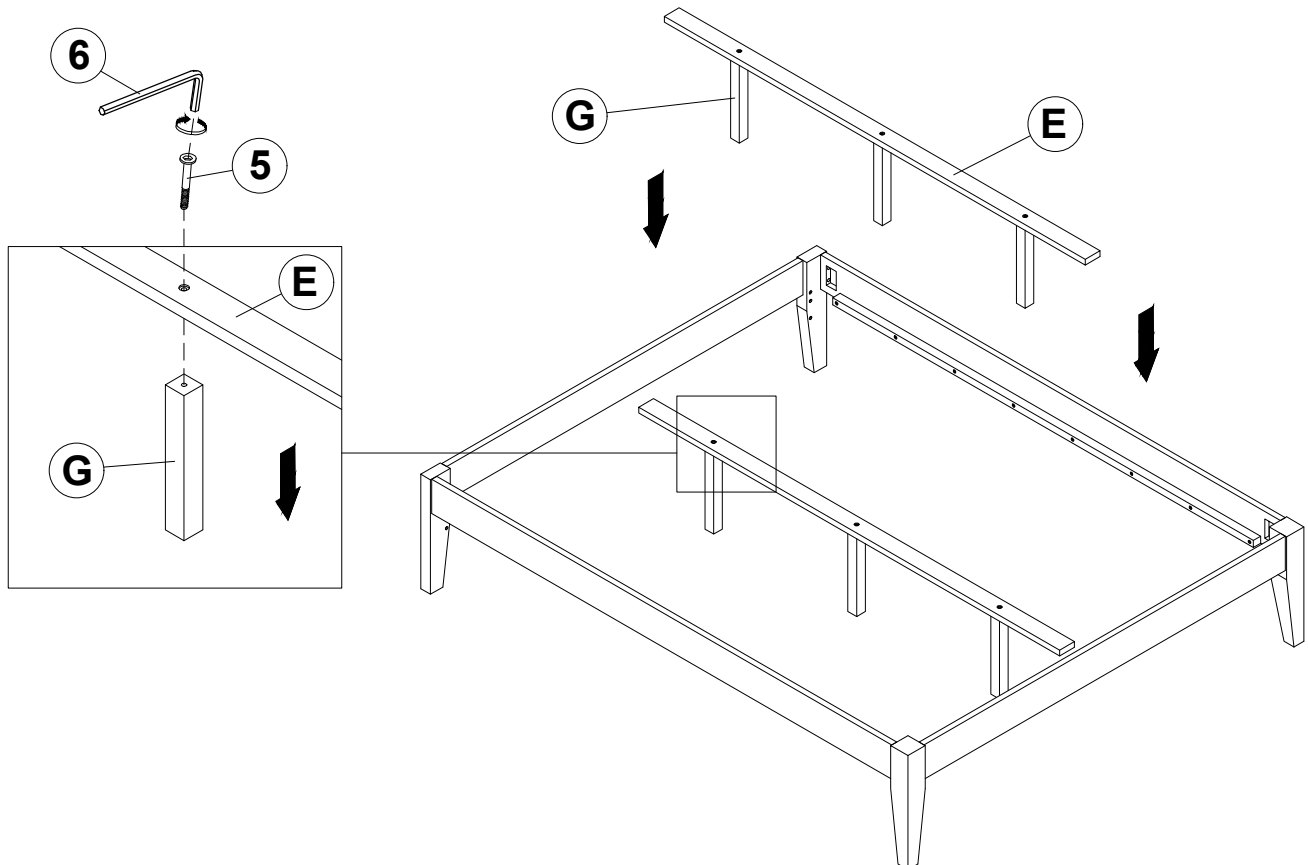

ITEM: 306129KW (B1&B2)

ASSEMBLY INSTRUCTIONS

STEP 3

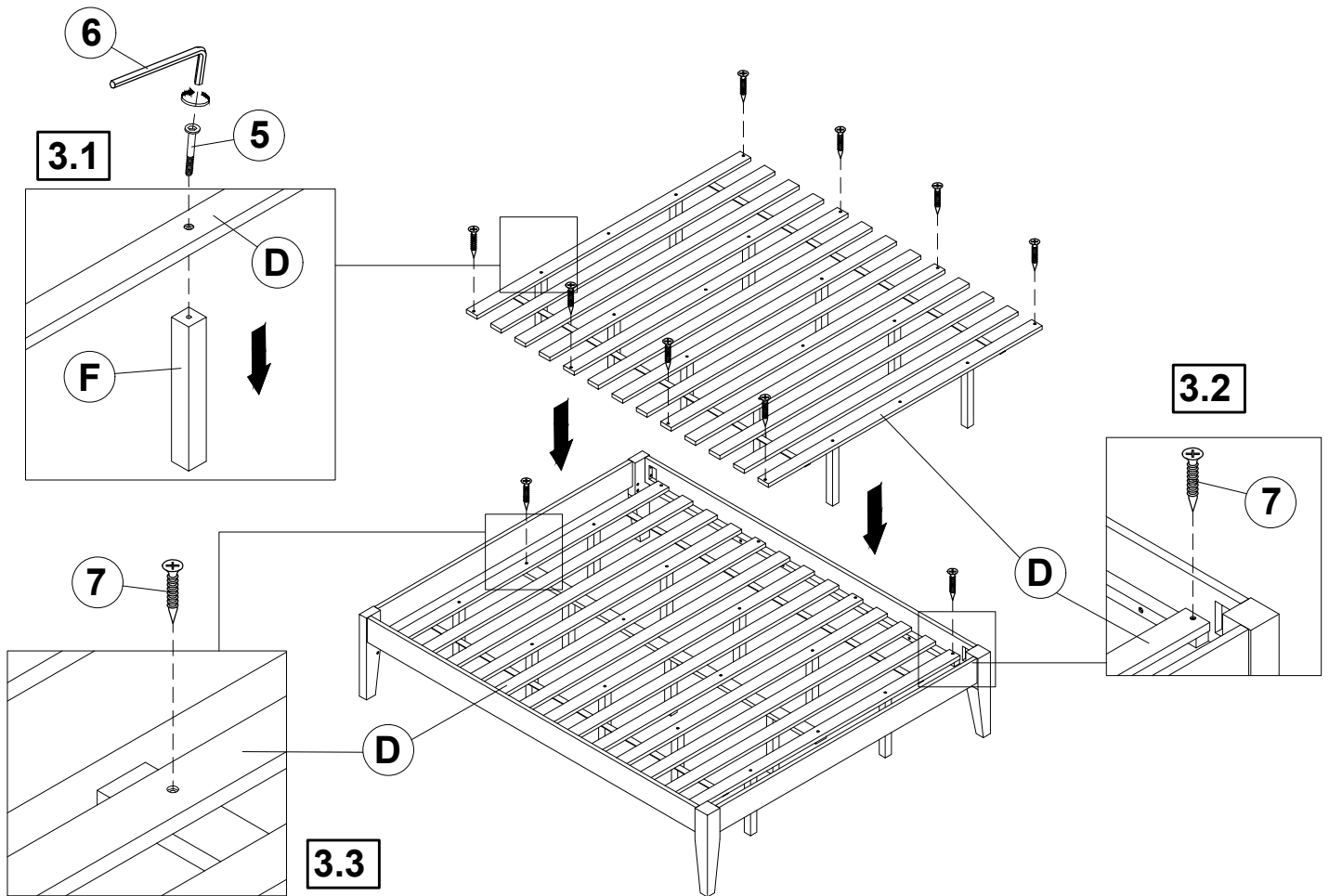

STEP 4

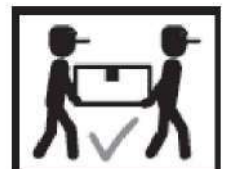
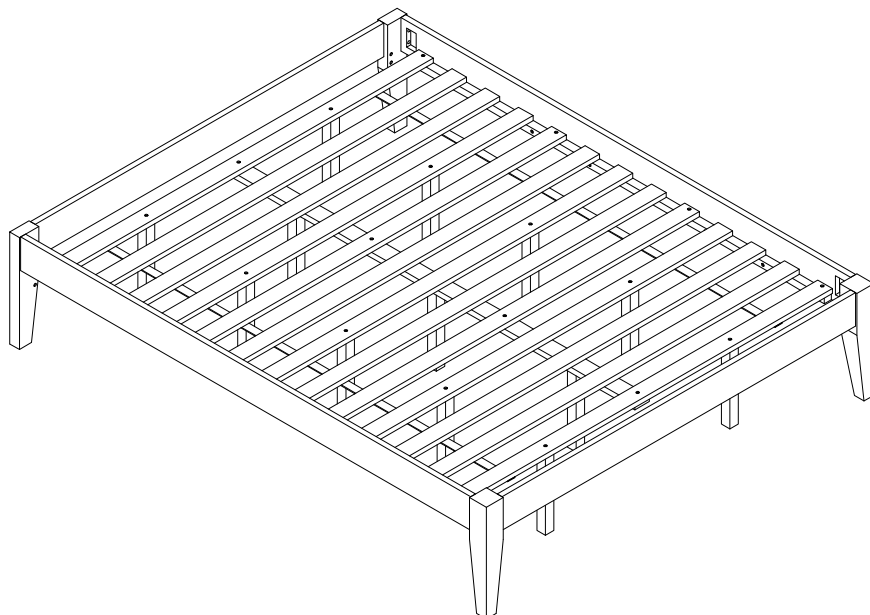

ITEM: **306129KW (B1&B2)**



Inner Size: 73.50"W X 85.00"D

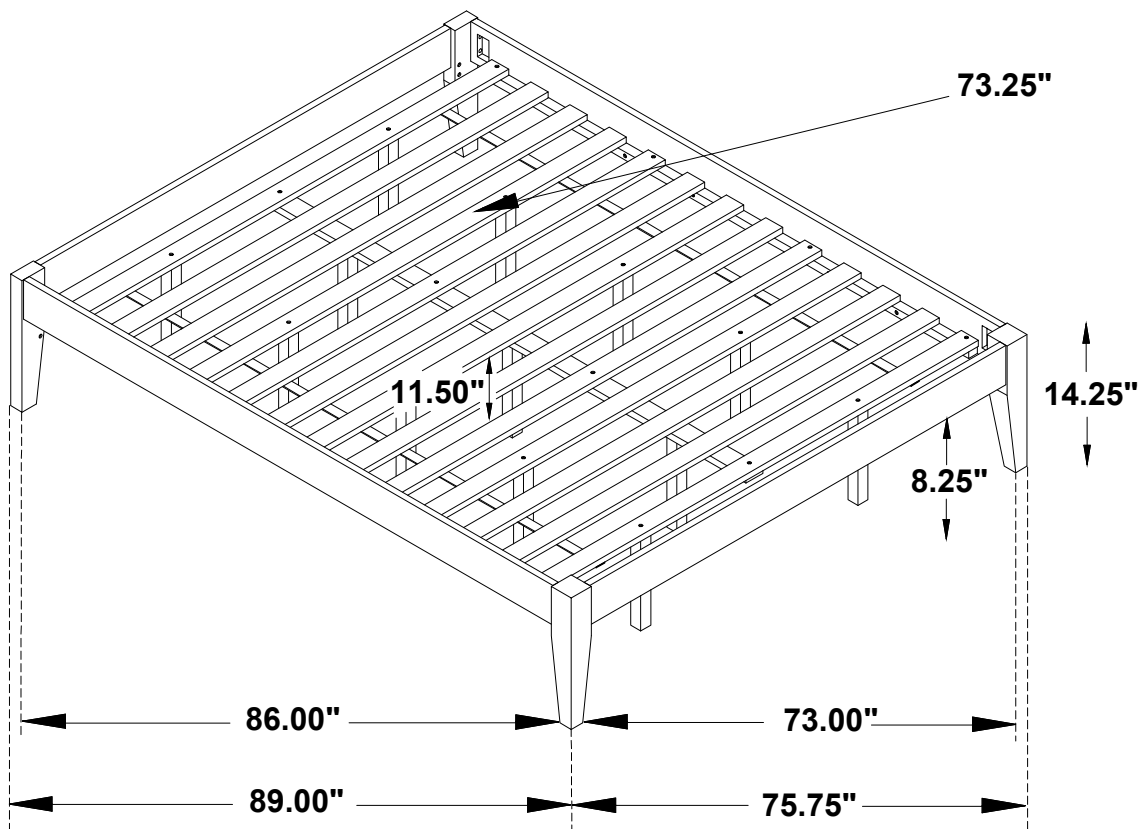

Note: Dimension tolerance $\pm 5\%$