

ASSEMBLY INSTRUCTIONS
COASTER FINE FURNITURE

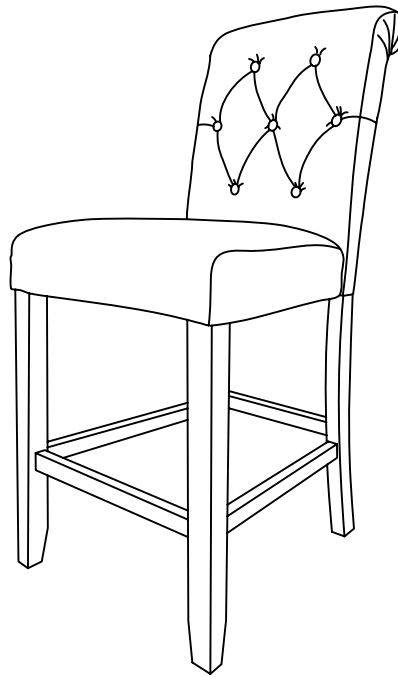

Fine Furniture for every stage of life

193168
Counter Height Stool

ITEM: 193168

ASSEMBLY INSTRUCTIONS



ASSEMBLY TIPS:

1. Remove hardware from box and sort by size.
2. Please check to see that all hardware and parts are present prior to start of assembly.
3. Please follow attached instructions in the same sequence as numbered to assure fast & easy assembly.



WARNING!





1. Don't attempt to repair or modify parts that are broken or defective. Please contact the store immediately.
2. This product is for home use only and not intended for commercial establishments.







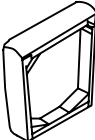

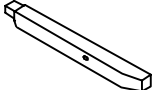
ASSEMBLY TIME

15 MINUTES

PARTS IDENTIFICATION

A	BACK FRAME		1PC	D	SIDE STRETCHER		2PCS
B	SEAT CUSHION WITH FRAME		1PC	E	FRONT STRETCHER		1PC
C	FRONT LEG		2PCS				

HARDWARE IDENTIFICATION

1	LONG BOLT (5/16" x 3-1/2"-RBW)		4PCS	5	FLAT WASHER (5/16" x 22mm-RWB)		9PCS
2	SHORT BOLT (5/16" x 2-1/4"-RBW)		5PCS	6	WOOD DOWEL (Ø10 x 30mm-WOOD)		2PCS
3	ALLEN WRENCH (5 mm-RBW)		1PC	7	FLAT HEAD SCREW (Ø8 x 1-3/4"-RWB)		6PCS
4	LOCK WASHER (5/16"-RBW)		9PCS				

NOTE:

Quantities shown are for one stool.

Phillips head screw driver is required in the assembly process; however, manufacturer does not provide this item.

ITEM: **193168**



ASSEMBLY INSTRUCTIONS

STEP 1

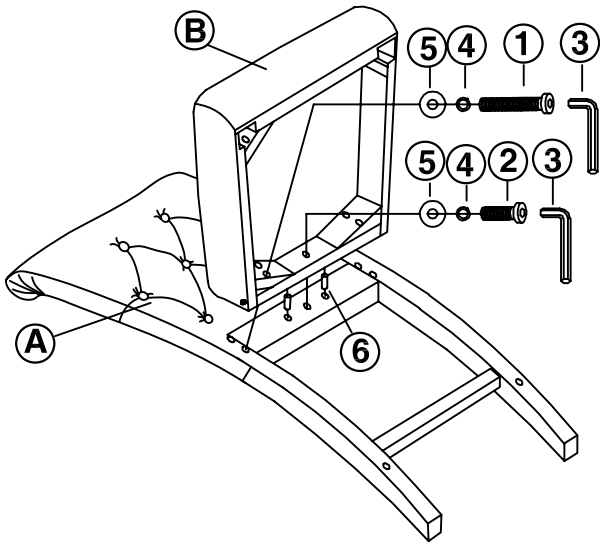

STEP 2

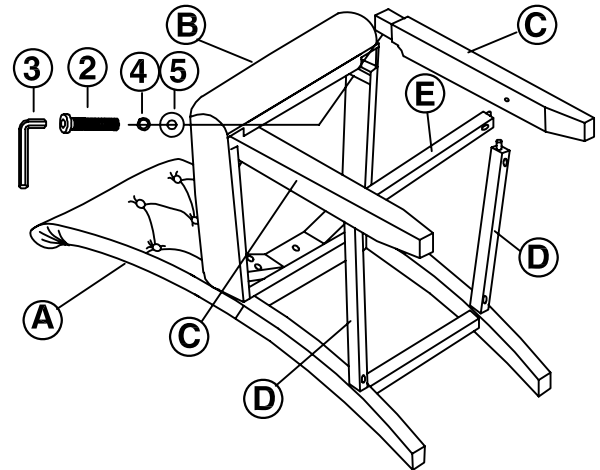

STEP 3

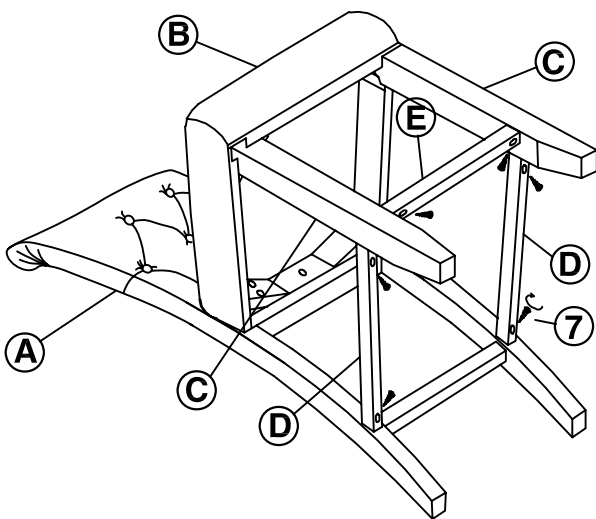

STEP 4
COMPLETE

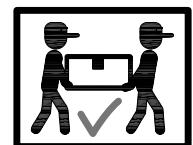
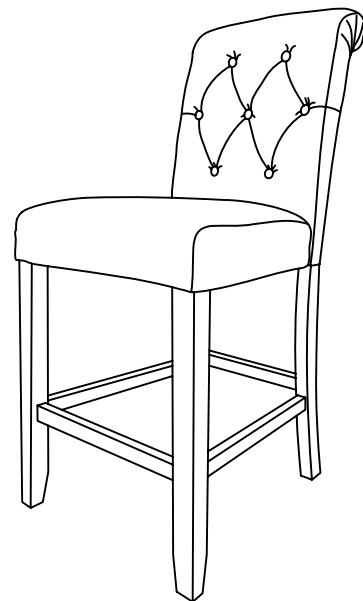

ITEM: **193168**

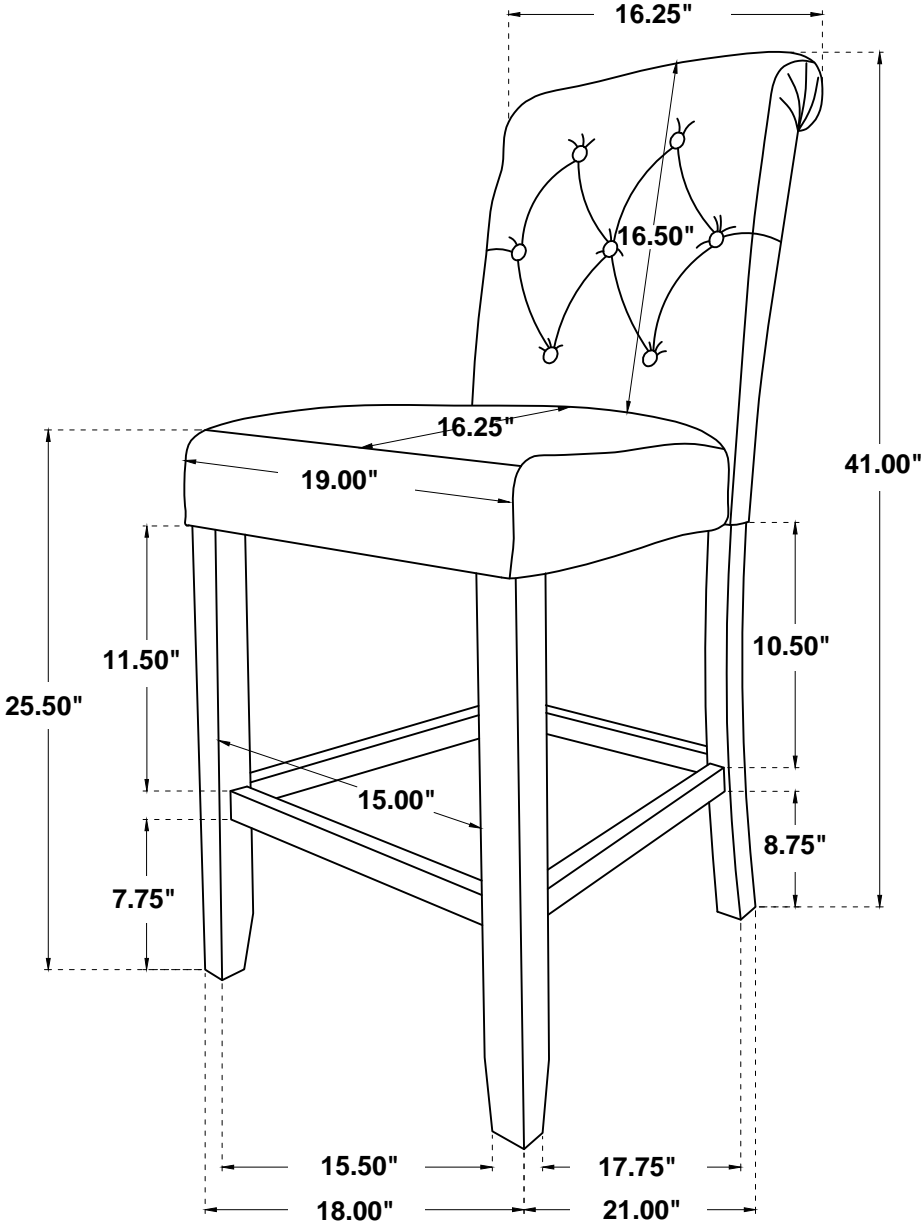

Note: Dimension tolerance $\pm 5\%$