

ASSEMBLY INSTRUCTIONS
COASTER FINE FURNITURE

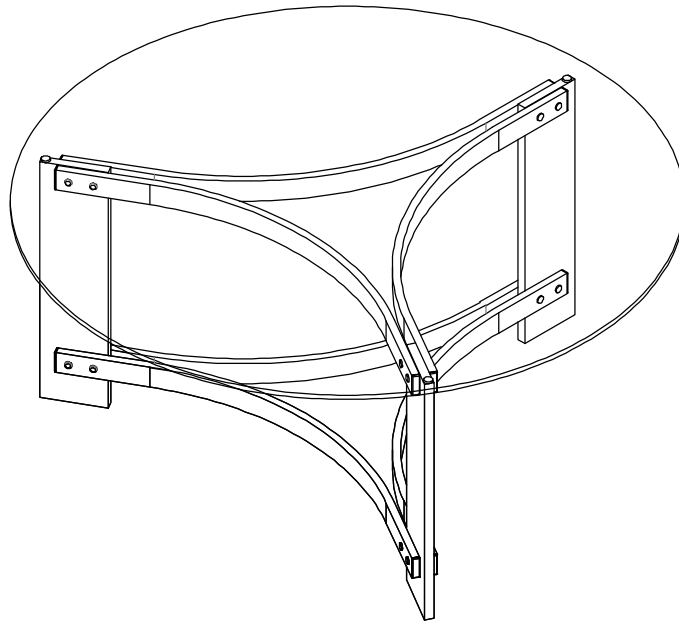

Fine Furniture for every stage of life

710068
COFFEE TABLE

ITEM: 710068



ASSEMBLY INSTRUCTIONS

ASSEMBLY TIPS:

1. Remove hardware from box and sort by size.
2. Please check to see that all hardware and parts are present prior to start of assembly.
3. Please follow attached instructions in the same sequence as numbered to assure fast & easy assembly.



WARNING!

1. Don't attempt to repair or modify parts that are broken or defective. Please contact the store immediately.
2. This product is for home use only and not intended for commercial establishments.

ASSEMBLY TIME 30 MINUTES

PARTS IDENTIFICATION

A TOP GLASS

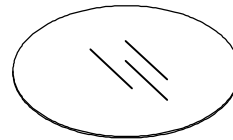

1PC

B CROSSBAR

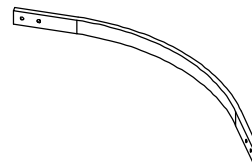

6PCS

C ACRYLIC LEG

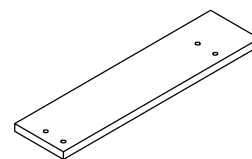

3PCS

Z

HARDWARE IDENTIFICATION

1

BOLT
(1/4" x 38mm GD)



12PCS

4

SUCTION CUP
(ϕ 12mm)



6PCS

2

NUT
(ϕ 1/4")



12PCS

5

CAP
(13 x 38mm GD)

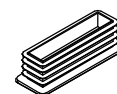

12PCS

3

COVER
(ϕ 11mm)



12PCS

6

ALLEN WRENCH
(4mm)



1PC

ITEM: 710068



ASSEMBLY INSTRUCTIONS

STEP 1 Do not tighten until each step is completed or instructed.

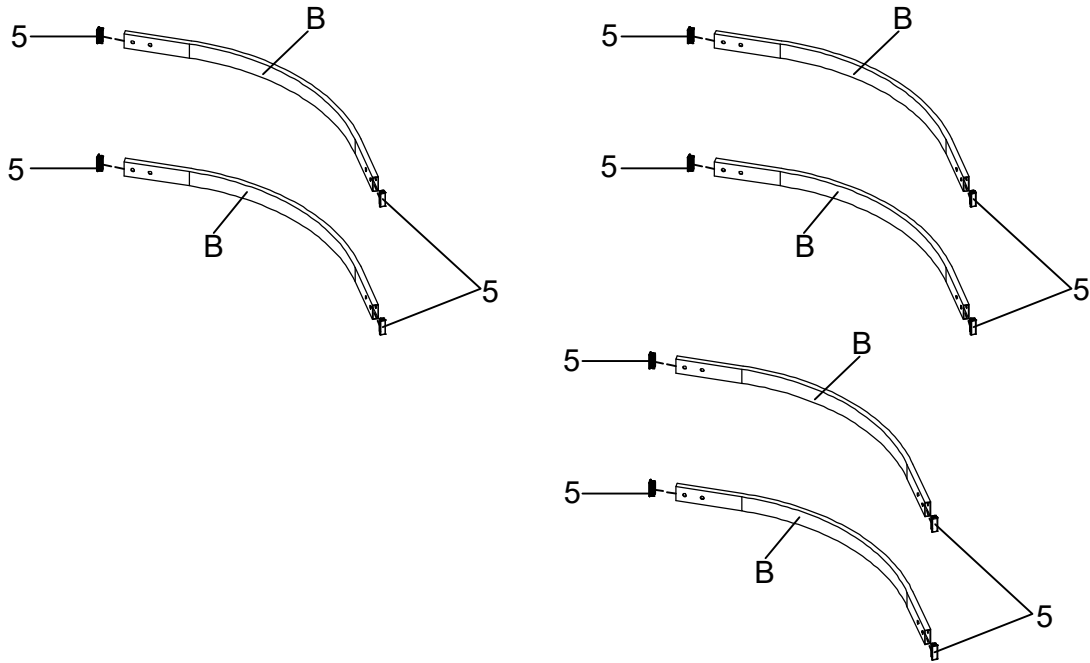

STEP 2

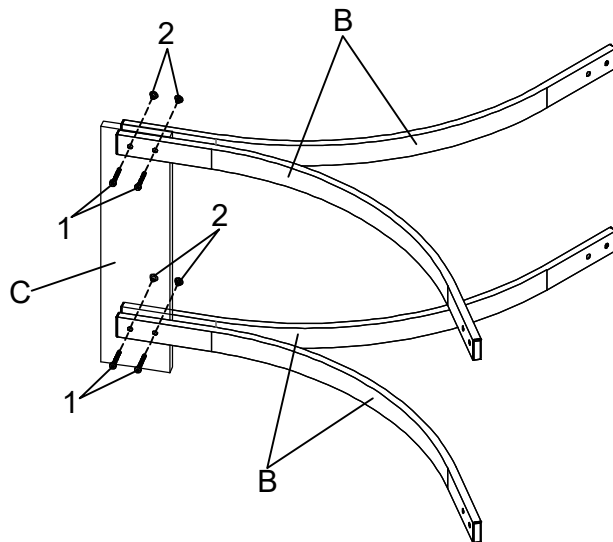

ITEM: 710068

ASSEMBLY INSTRUCTIONS

STEP 3

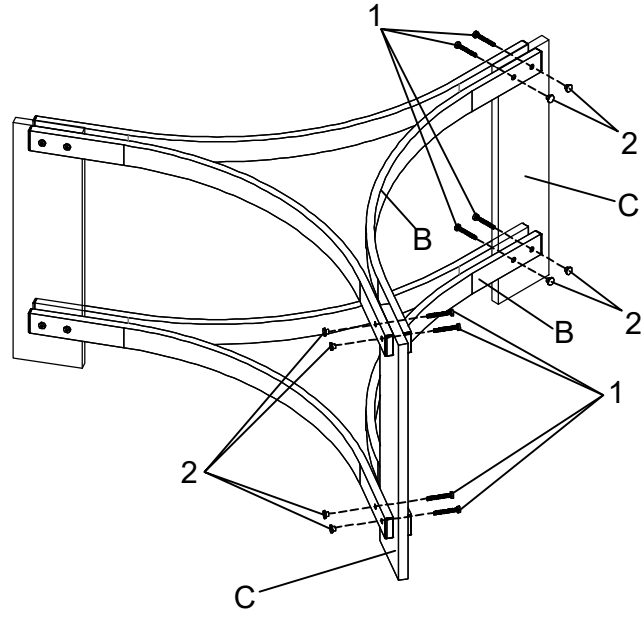

STEP 4

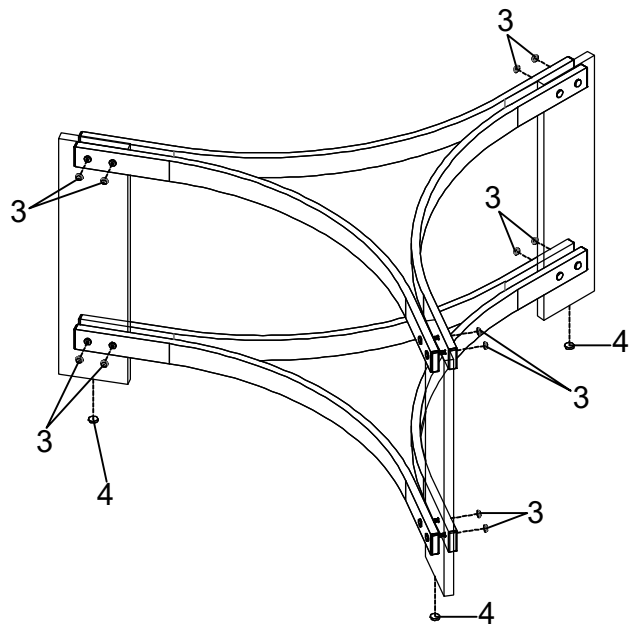

ITEM: 710068

ASSEMBLY INSTRUCTIONS

STEP 5

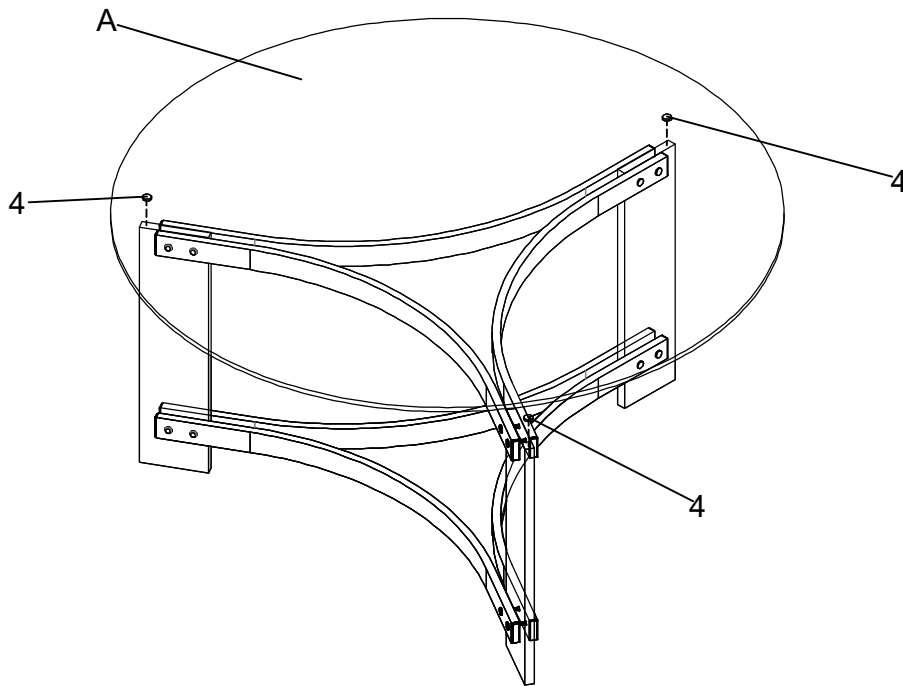

STEP 6 COMPLETE

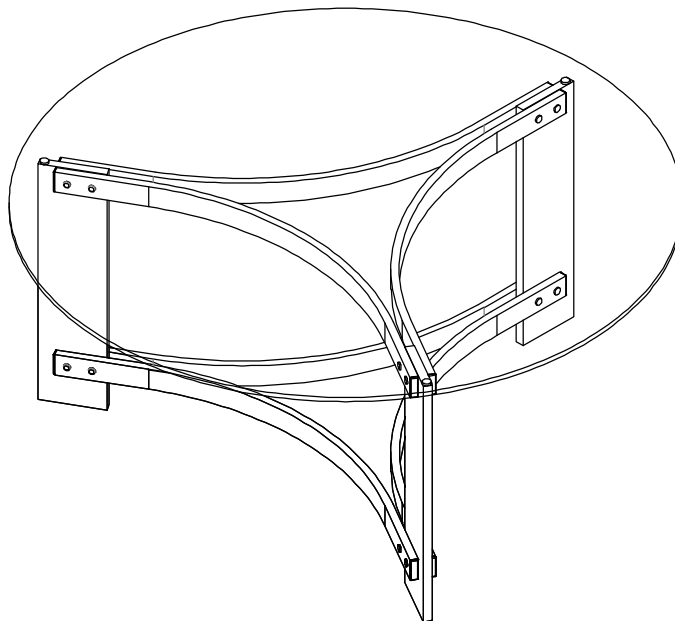

How to clean Acrylic product:
Using a dry soft microfiber cloth, lightly brush off any dust.
For additional care, dampen the cloth with warm water.
For deepest cleaning, use an Acrylic cleaner.

ITEM: 710068

ASSEMBLY INSTRUCTIONS



Product Size : 1041 DIA X 457 H (MM)
Product Size : 41" DIA X 18" H

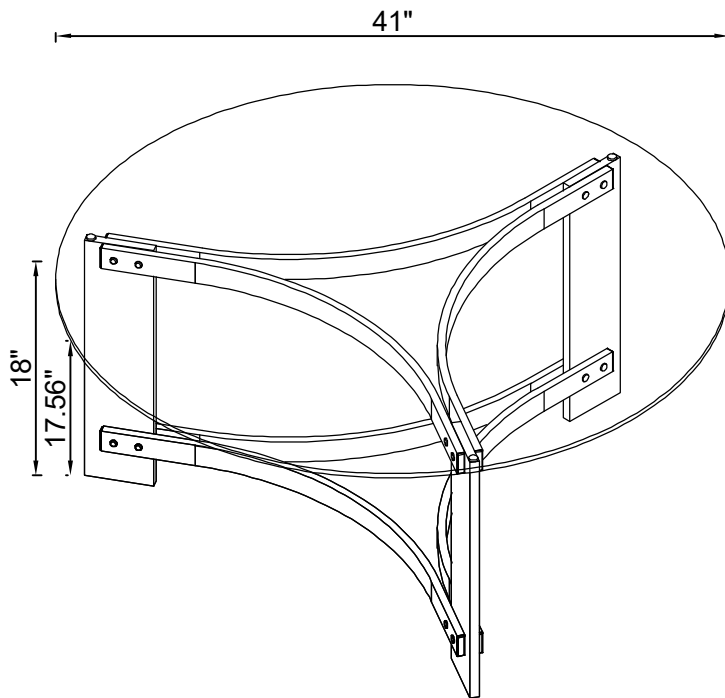

Note : Dimension tolerance $\pm 5\%$