

ASSEMBLY INSTRUCTIONS
COASTER FINE FURNITURE

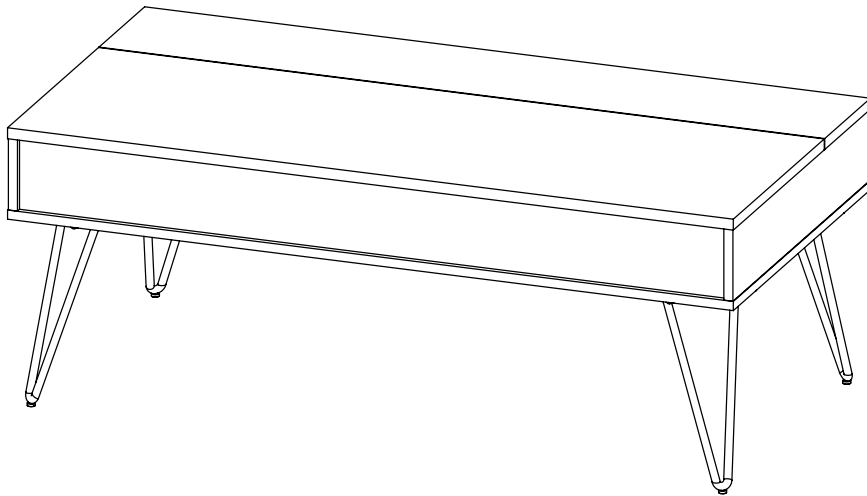

Fine Furniture for every stage of life

723368
LIFT TOP COFFEE TABLE

ITEM: 723368



ASSEMBLY INSTRUCTIONS

ASSEMBLY TIPS:

1. Remove hardware from box and sort by size.
2. Please check to see that all hardware and parts are present prior to start of assembly.
3. Please follow attached instructions in the same sequence as numbered to assure fast & easy assembly.



WARNING!

1. Don't attempt to repair or modify parts that are broken or defective. Please contact the store immediately.
2. This product is for home use only and not intended for commercial establishments.



ASSEMBLY TIME

60 MINUTES

PARTS IDENTIFICATION

A LEFT SIDE PANEL

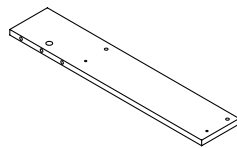

1 PC

B RIGHT SIDE PANEL

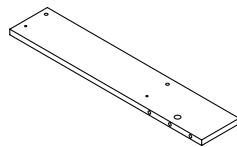

1 PC

C LEFT DIVIDER PANEL

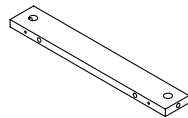

1 PC

D RIGHT DIVIDER PANEL

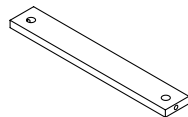

1 PC

E BACK DIVIDER PANEL

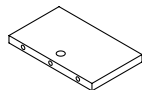

1 PC

F BOTTOM PANEL

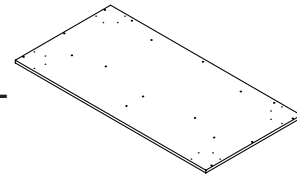

1 PC

G LARGE TOP PANEL

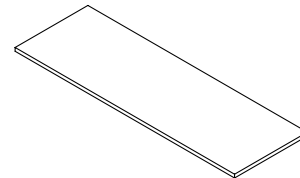

1 PC

H SMALL TOP PANEL

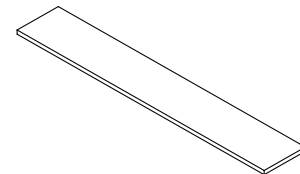

1 PC

I CROSS BRACE

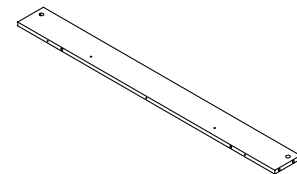

2 PCS

J LEG

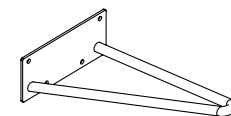

4 PCS









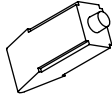
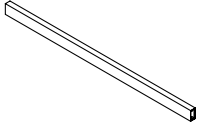
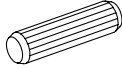

NOTE:

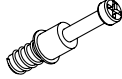
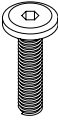
Phillips head screw driver is required in the assembly process; however, manufacturer does not provide this item.

ITEM:723368

HARDWARE IDENTIFICATION

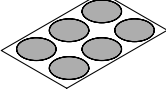
Z

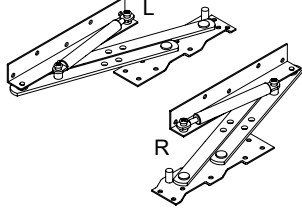
| NO | DESCRIPTION | FIGURE | Q'TY | NO | DESCRIPTION | FIGURE | Q'TY |
|----|--------------------------|---|--------|----|-------------------------|---|--------|
| 1 | GLUE 40g |  | 1 PC | 9 | CROSSBAR L=600mm BLK |  | 1 PC |
| 2 | WOODEN DOWEL Ø8x30mm |  | 24 PCS | 10 | BOLT Ø5.8x16mm BLK |  | 12 PCS |
| 3 | CAM BOLT Ø7x35.5mm SR |  | 11 PCS | 11 | BOLT M6x28mm BLK |  | 4 PCS |
| 4 | CAM LOCK Ø15x12mm SR |  | 11 PCS | 12 | BOLT M6x15mm BLK |  | 4PCS |
| 5 | SCREW Ø4.5x42mm SR |  | 17 PCS | 13 | ALLEN WRENCH 4mm SR |  | 1 PC |
| 6 | SCREW Ø5x19mm BLK |  | 16 PCS | 14 | STICKER Ø20mm |  | 2 PCS |
| 7 | PLASTIC FEET |  | 4 PCS | | | | |
| 8 | LIFTER BLK |  | 1 SET | | | | |

Z8,Z9 not included in blister packaging.

NOTE:

Phillips head screw driver is required in the assembly process; however, manufacturer does not provide this item.

ITEM: 723368

COASTER
FINE FURNITURE

STEP 1

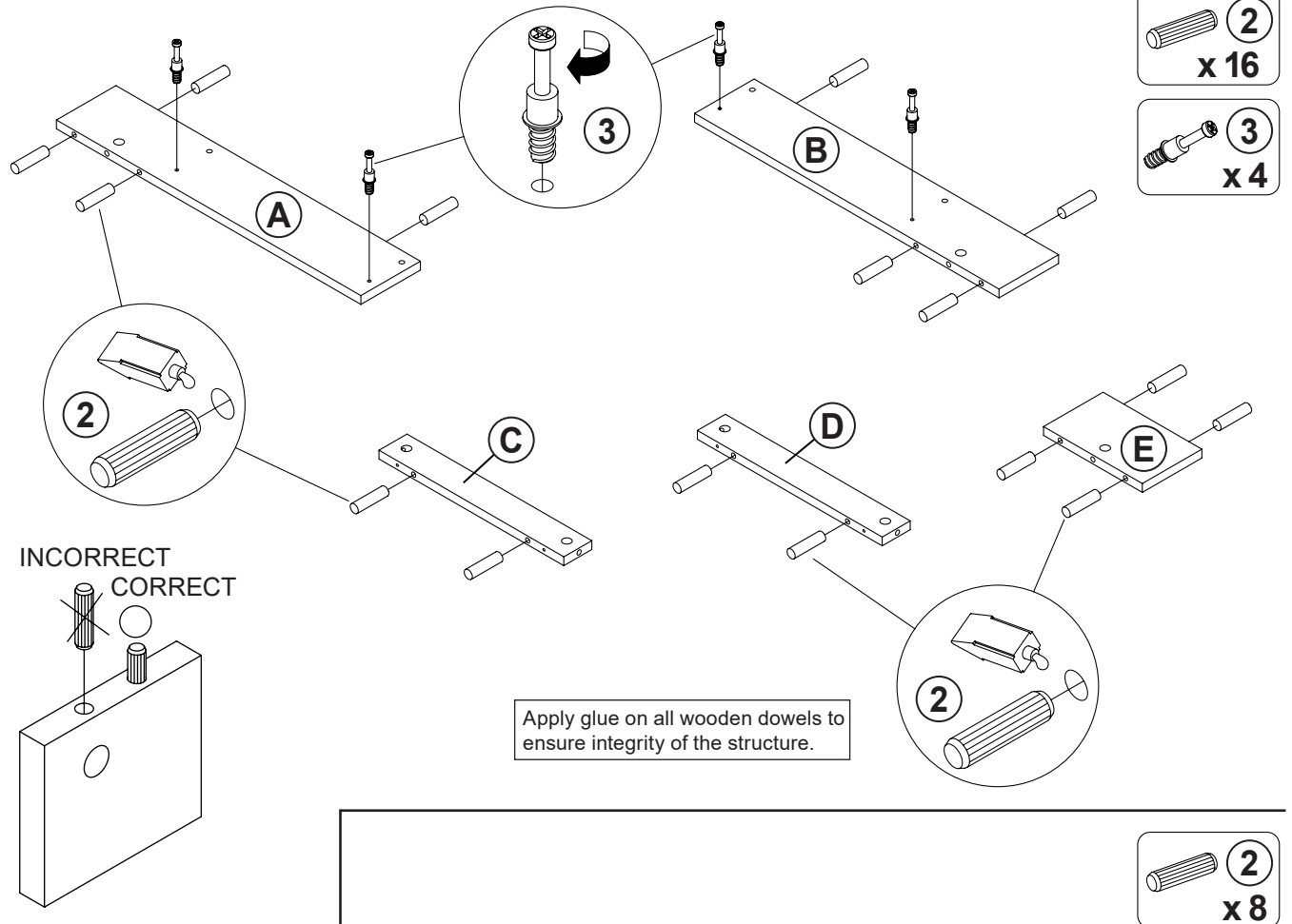

STEP 2

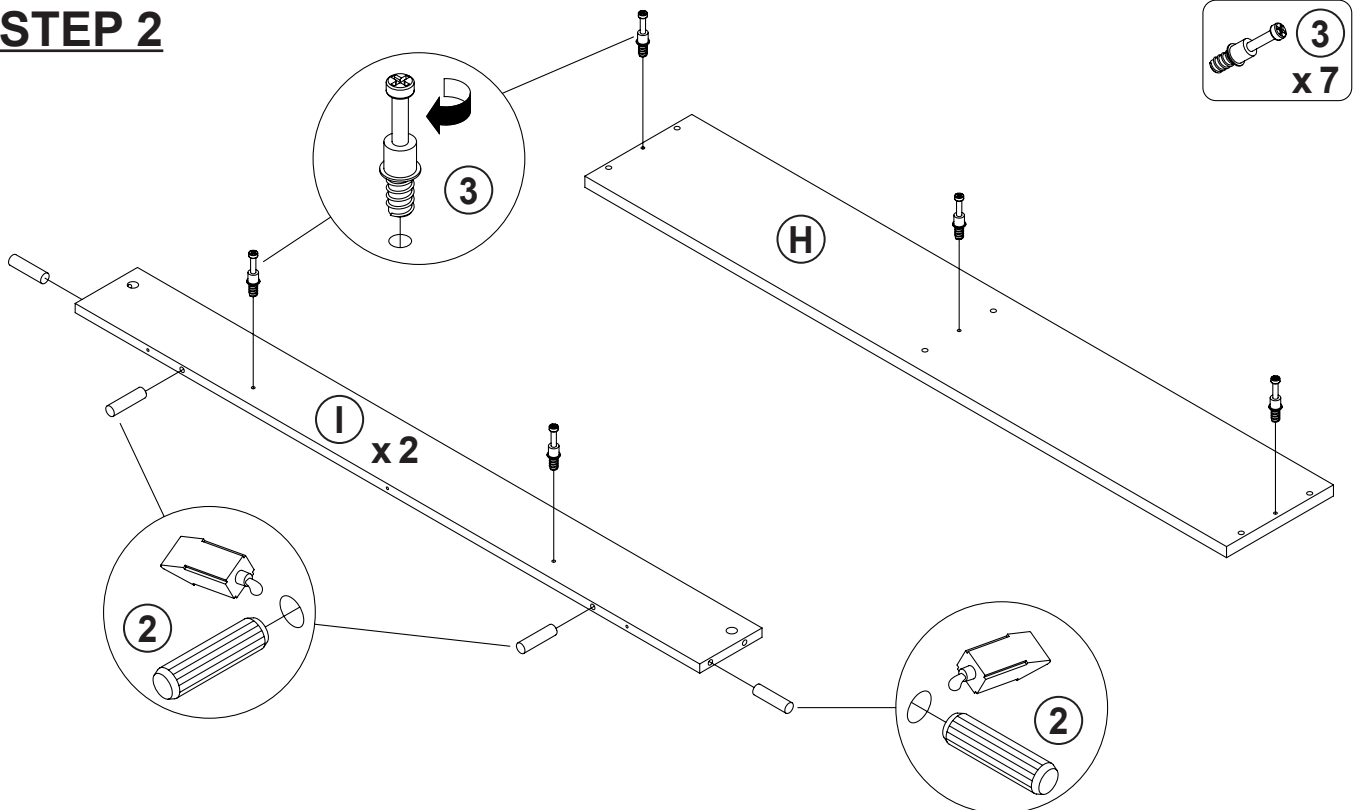

ITEM: 723368

COASTER
FINE FURNITURE

STEP 3

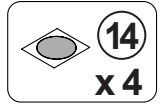
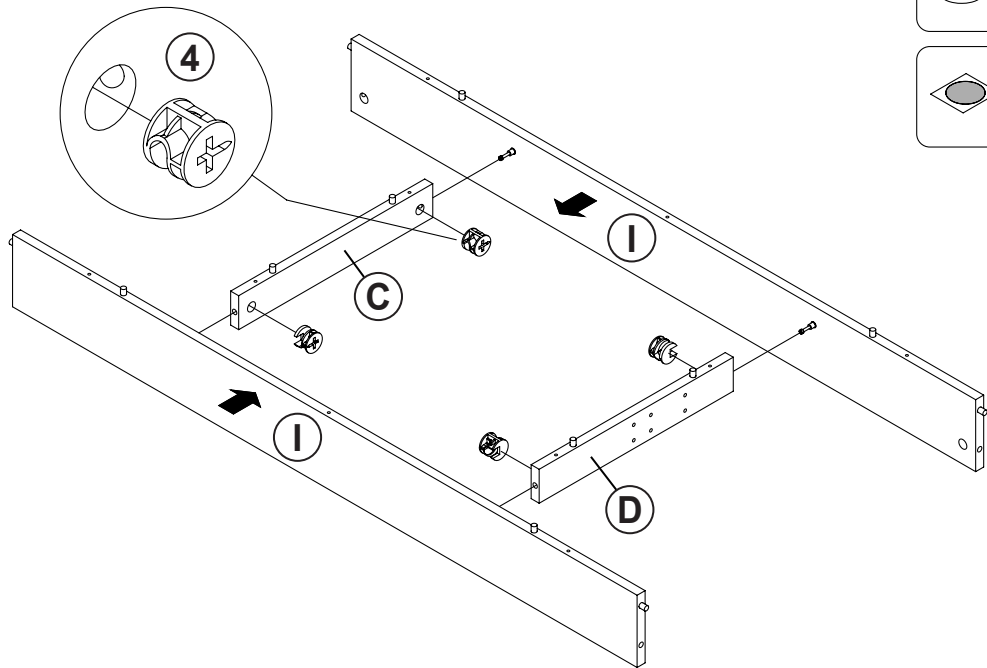
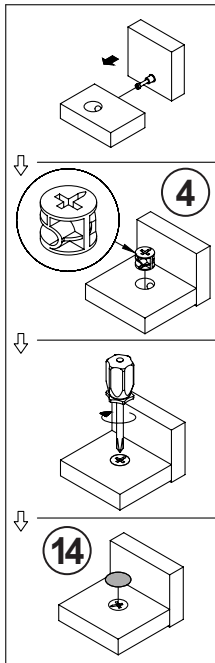

STEP 4

Apply glue on all wooden dowels to ensure integrity of the structure.

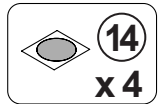
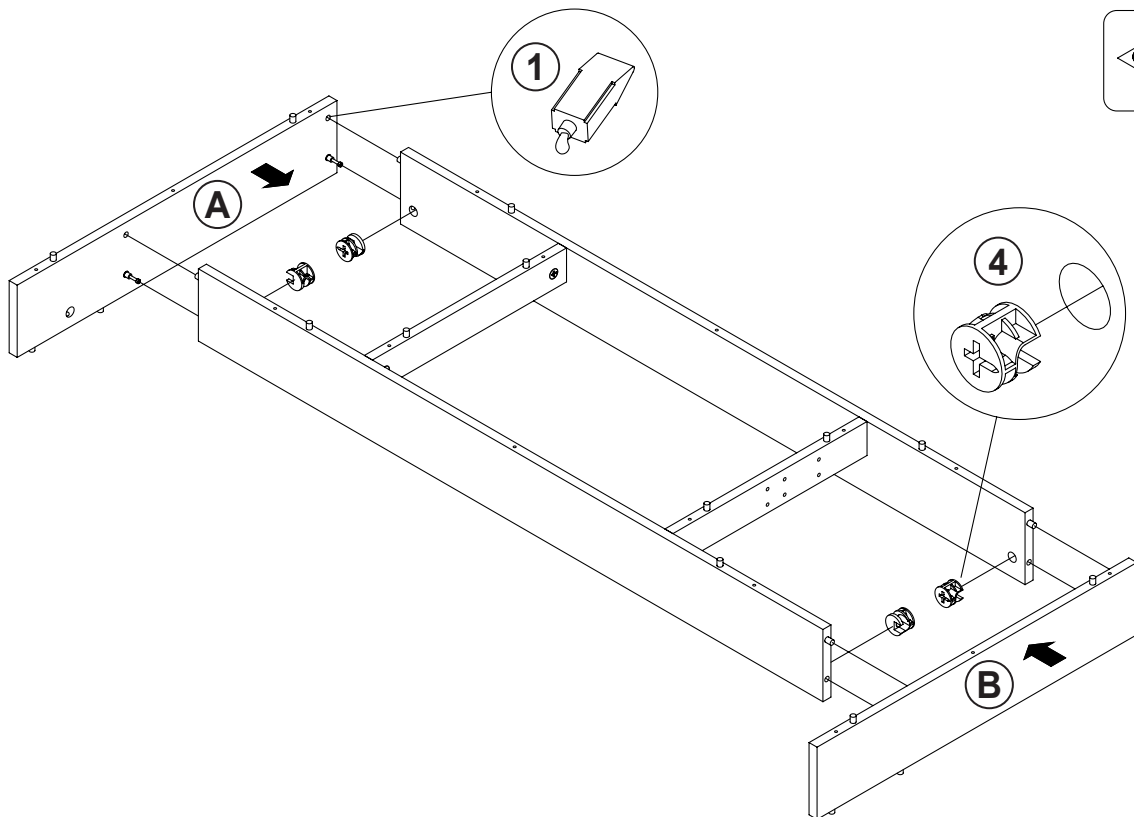

ITEM: 723368

COASTER[®]

FINE FURNITURE

STEP 5

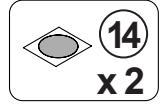
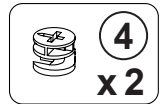
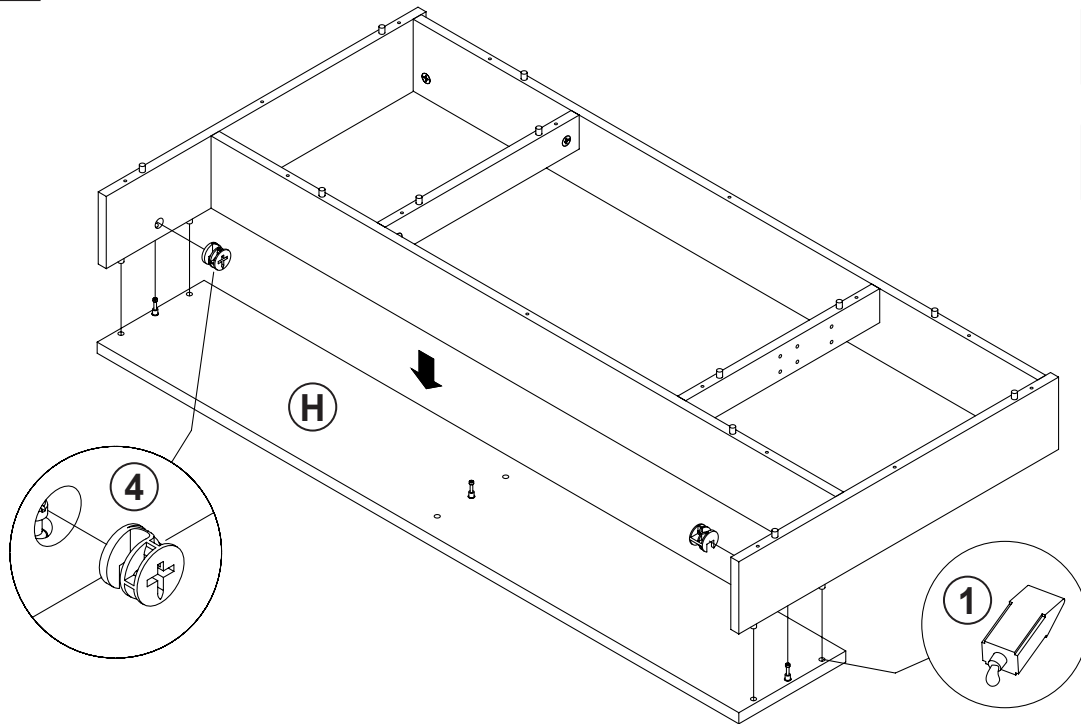

Apply glue on all wooden dowels to ensure integrity of the structure.

STEP 6

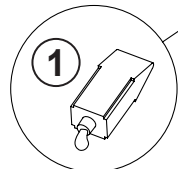
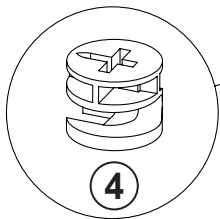
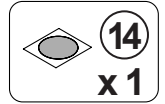
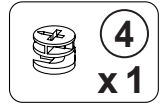
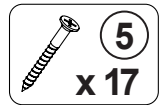
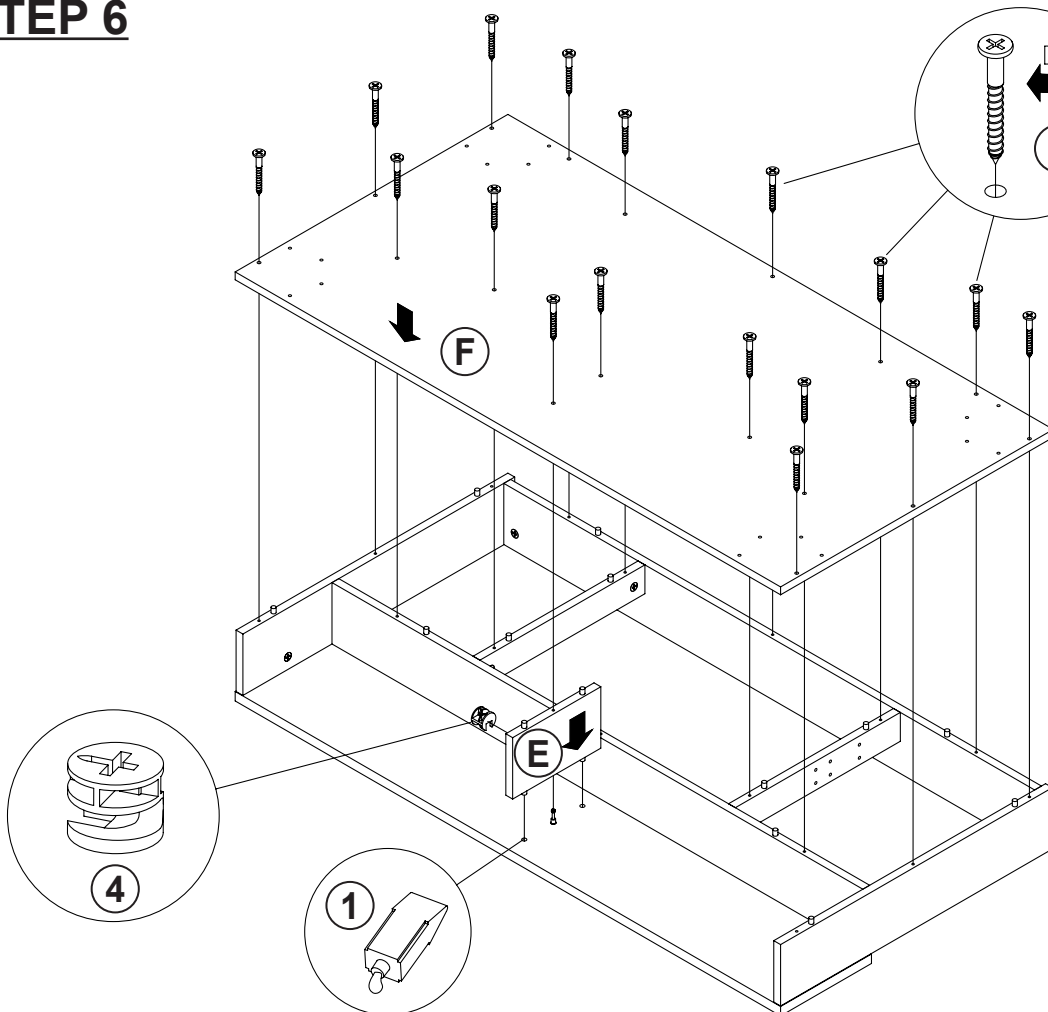

ITEM: 723368

STEP 7

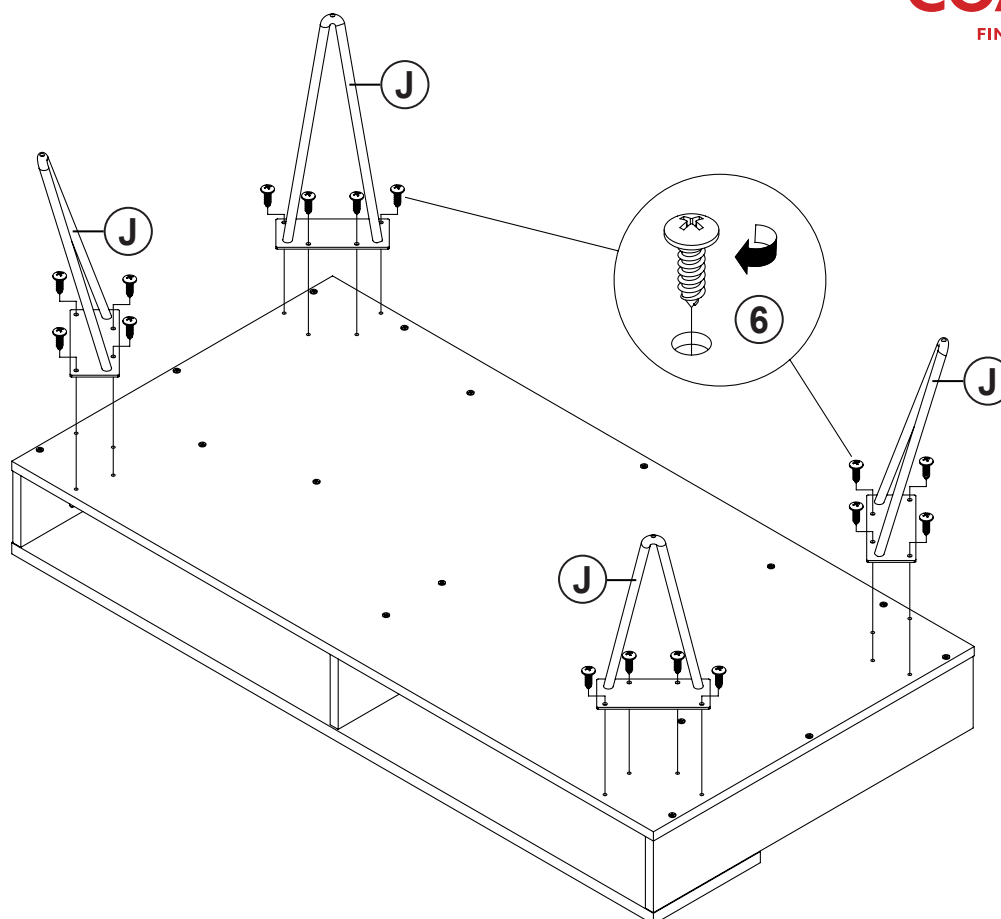
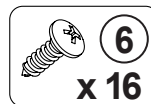

STEP 8

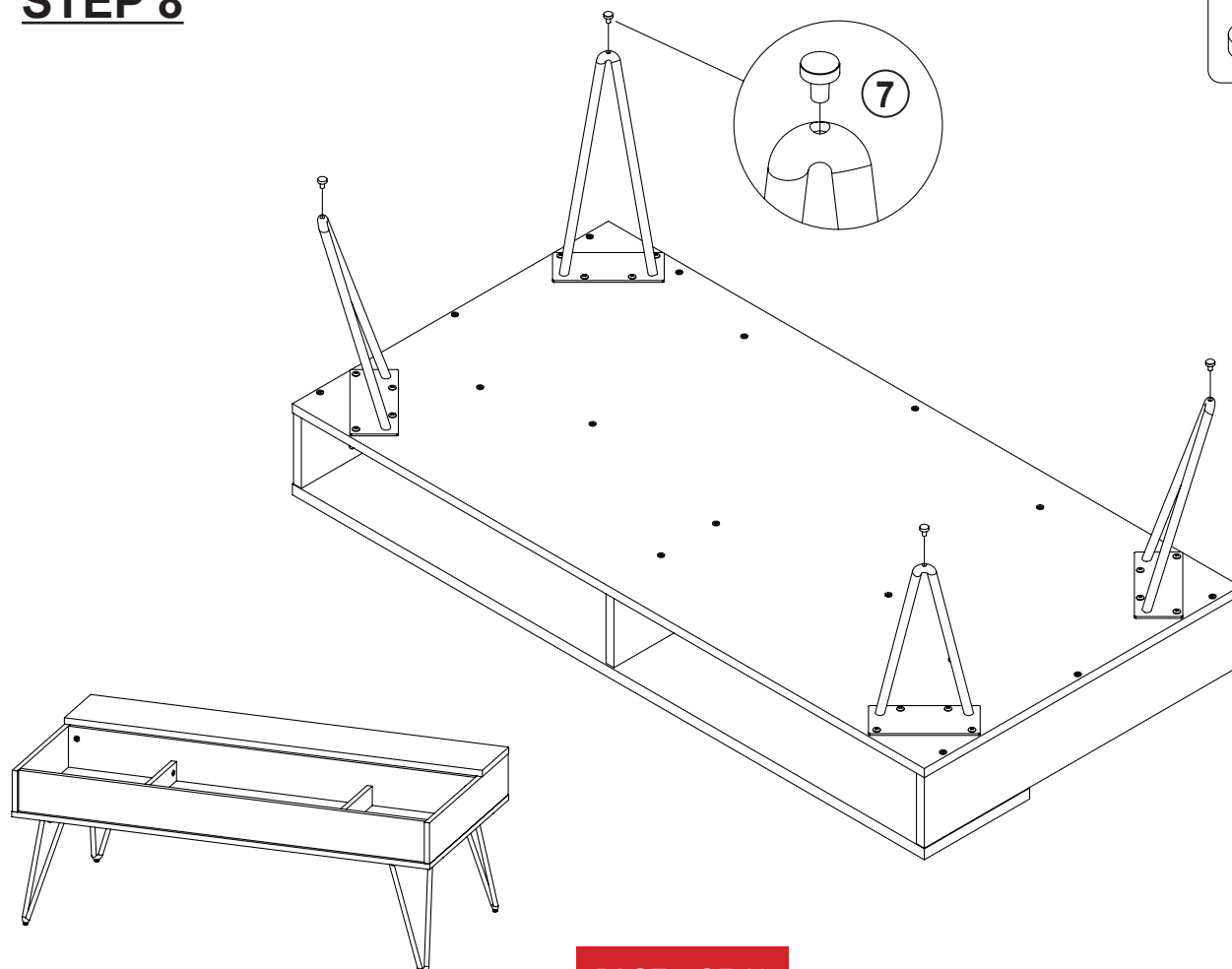
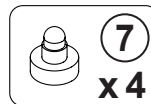

ITEM: 723368

COASTER
FINE FURNITURE

STEP 9

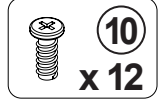
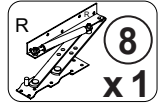
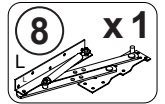
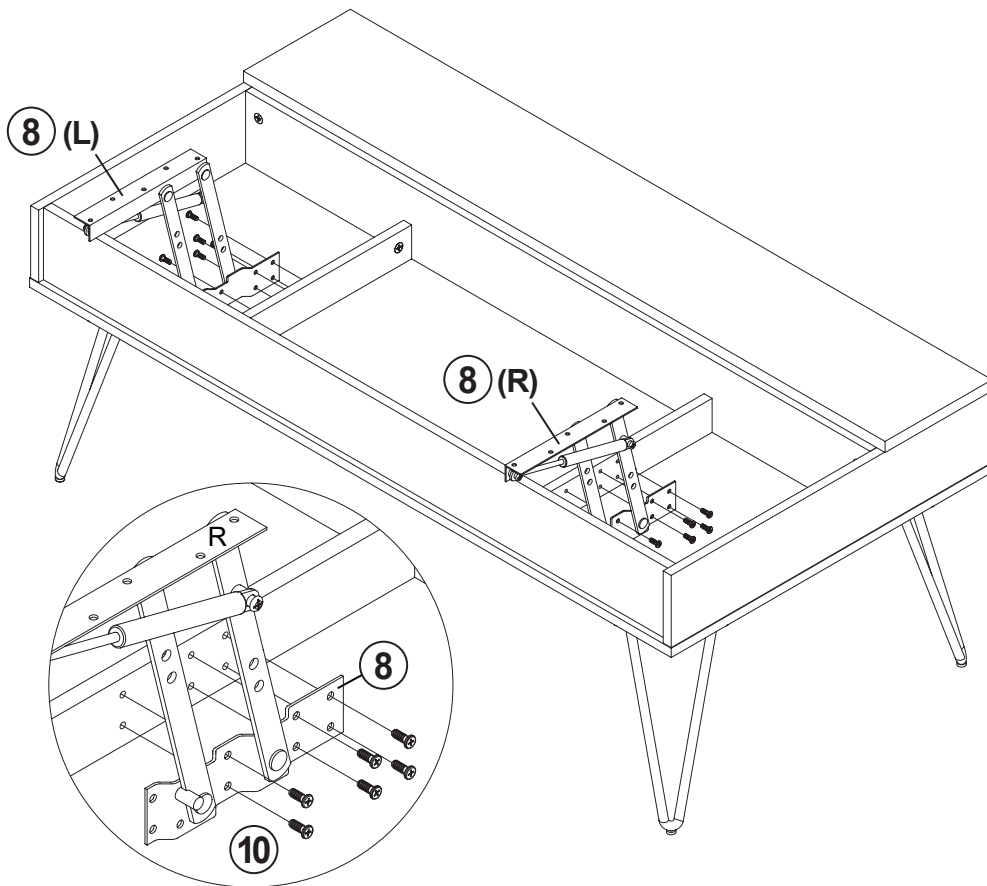

STEP 10

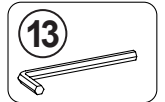
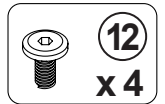
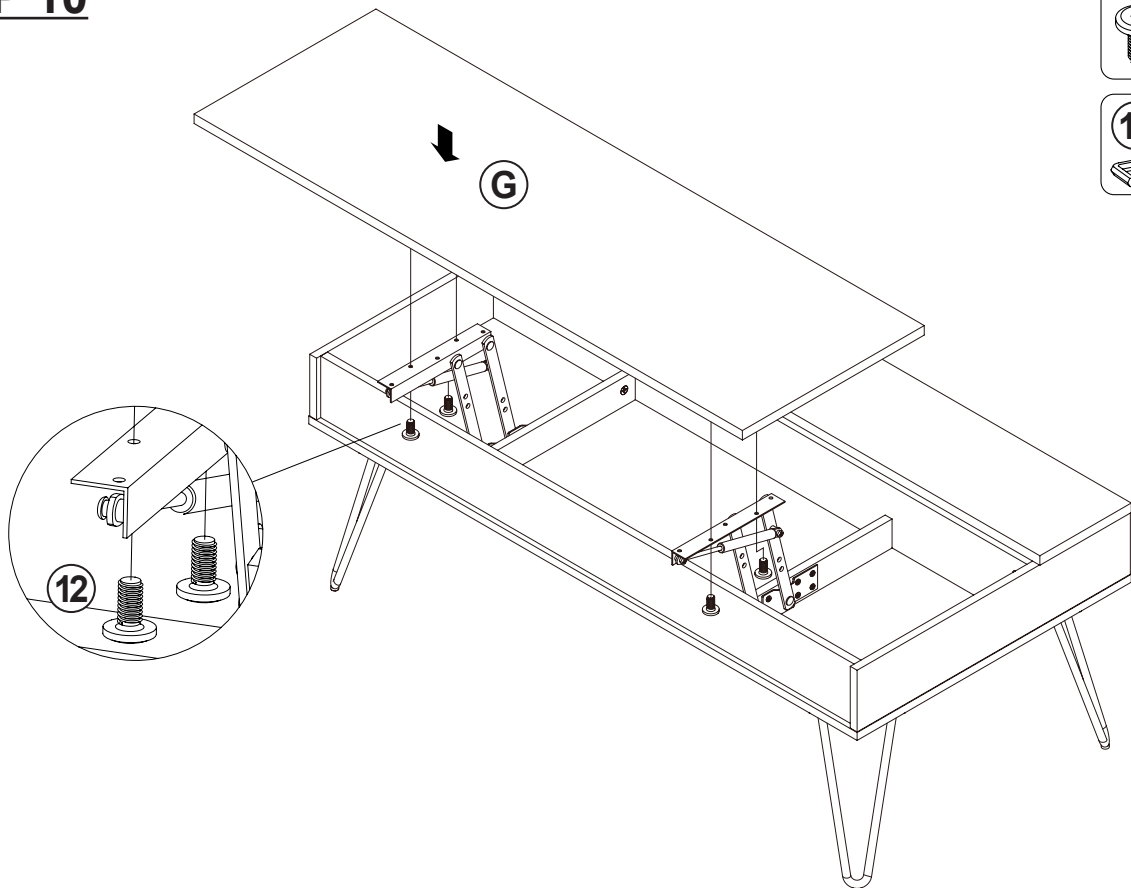

ITEM: 723368

COASTER
FINE FURNITURE

STEP 11

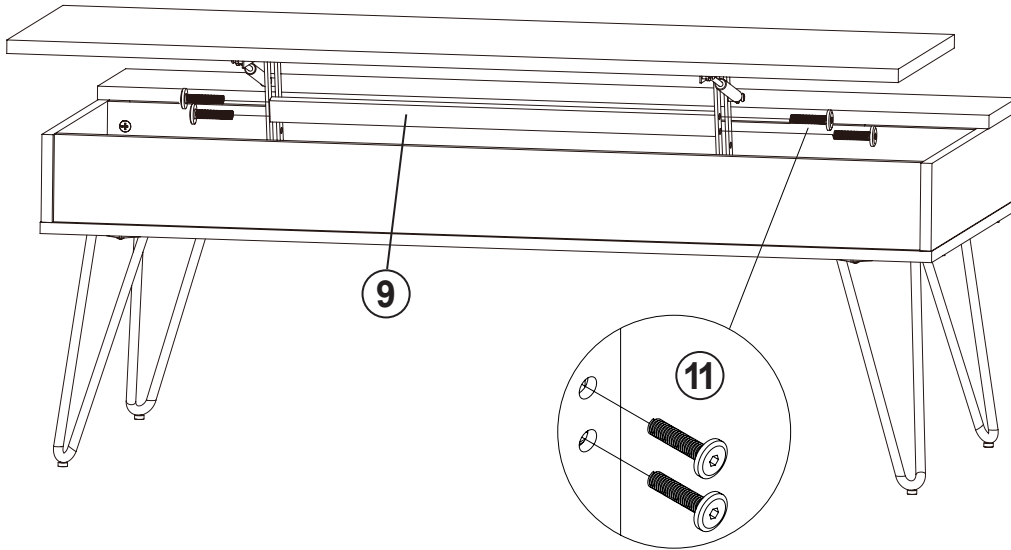
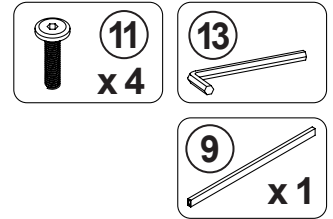

STEP 12

COMPLETE

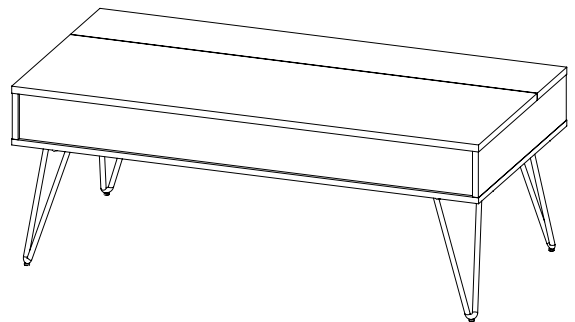
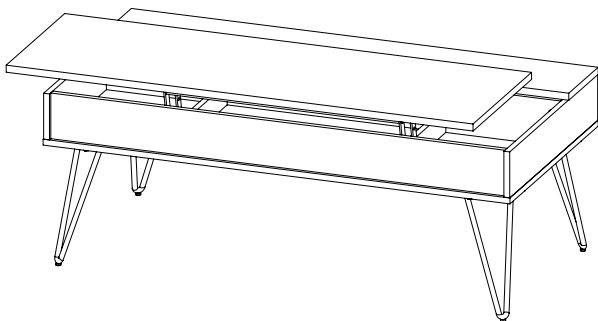

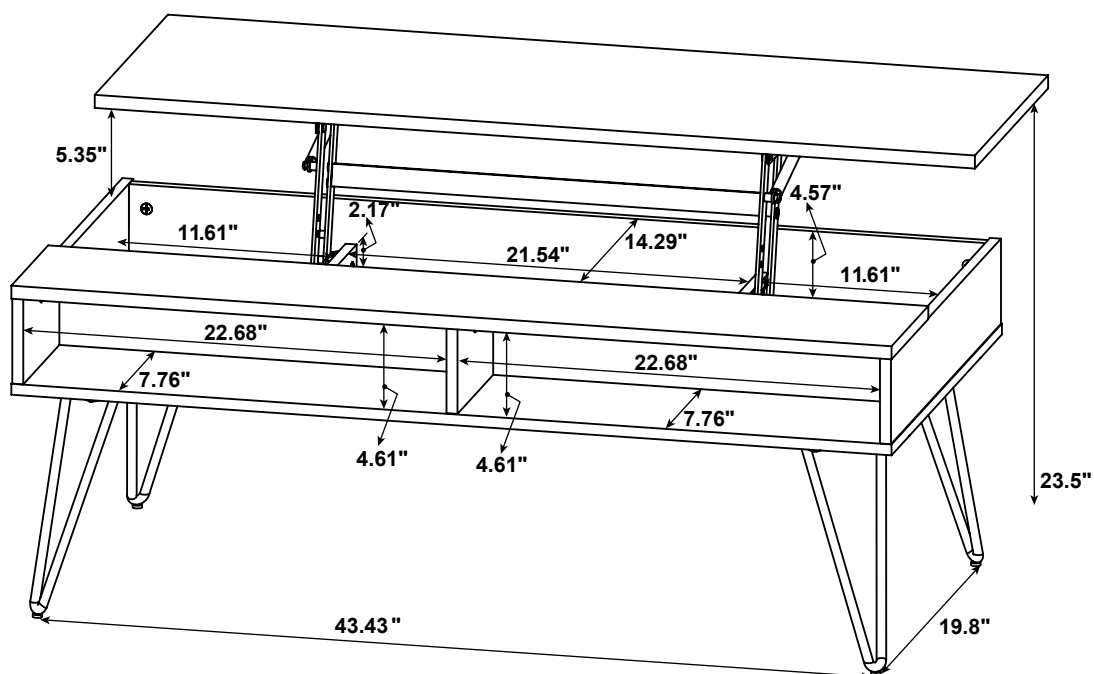
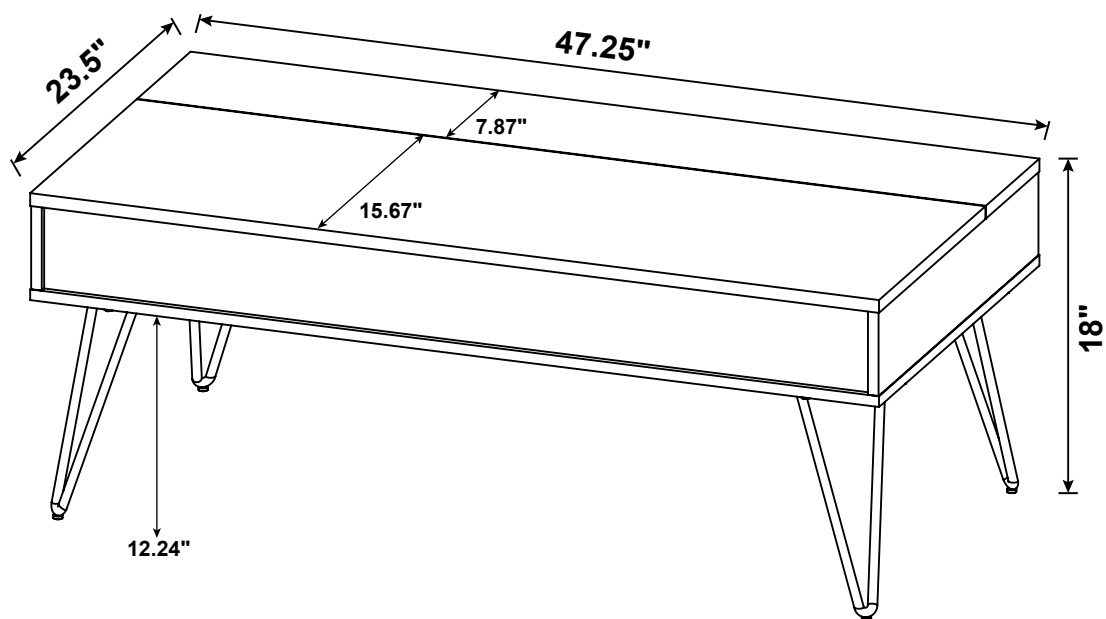

Note : Dimension tolerance $\pm 5\%$