



ASSEMBLY INSTRUCTIONS COASTER FINE FURNITURE



Fine Furniture for every stage of life

204391KW(B1&B2) California King Bed

REVISION 0 : 11/09/2016
REVISION 1 : 01/21/2020

PAGE 1 OF 5

COASTERFURNITURE.COM

ITEM: 204391KW (B1&B2)



ASSEMBLY INSTRUCTIONS

ASSEMBLY TIPS:

- 1 . Remove hardware from box and sort by size.
- 2 . Please check to see that all hardware and parts are present prior to start of assembly.
- 3 . Please follow attached instructions in the same sequence as numbered to assure fast & easy assembly.

WARNING !



- 1 . Don't attempt to repair or modify parts that are broken or defective. Please contact the store immediately.
- 2 . This product is for home use only and not intended for commercial establishment.

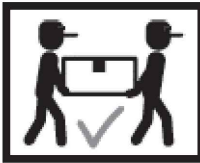



ASSEMBLY TIME

30 MINUTES

PARTS IDENTIFICATION

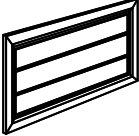
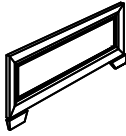
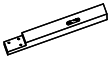
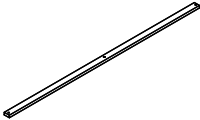
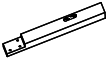
B1 (BOX 1)

A	HEADBOARD PANEL		1PC	D	FOOTBOARD		1PC
B	RIGHT HEADBOARD LEG		1PC	E	BED SLAT		4PCS
C	LEFT HEADBOARD LEG		1PC	F	BED SLAT SUPPORT WITH LEVELER		8PCS

B2 (BOX 2)

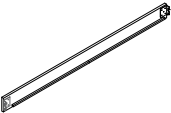
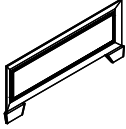
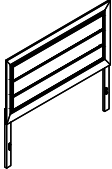
G	BED RAIL		2PCS	D	204391KW (B1) (FROM BOX 1) FOOTBOARD		1PC
HB	204391KW (B1) (FROM BOX 1) HEADBOARD COMPLETE		1PC				

ITEM: 204391KW (B1&B2)



ASSEMBLY INSTRUCTIONS

ASSEMBLY TIPS:

- 1 . Remove hardware from box and sort by size.
- 2 . Please check to see that all hardware and parts are present prior to start of assembly.
- 3 . Please follow attached instructions in the same sequence as numbered to assure fast & easy assembly.

WARNING !



- 1 . Don't attempt to repair or modify parts that are broken or defective. Please contact the store immediately.
- 2 . This product is for home use only and not intended for commercial establishment.

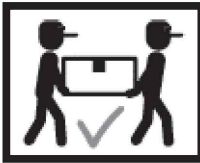





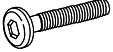

ASSEMBLY TIME

30 MINUTES

HARDWARE IDENTIFICATION

Z-B1 (BOX1) - HARDWARE PACK IS LOCATED IN 204391KW (B1)

1	BOLT (M6 x30mm - BLK)		6PCS	4	FLAT HEAD SCREW (M4 x 32mm - RBW)		8PCS
2	LOCK WASHER (1/4" - BLK)		6PCS	5	SMALL ALLEN WRENCH (M4 x 65mm - BLK)		1PC
3	FLAT WASHER (1/4" x13mm - BLK)		6PCS	6	BIG ALLEN WRENCH (M5 x 65mm - BLK)		1PC

NOTE:

Philips head screw driver in the assembly process ; however, manufacturer does not provide the item

ITEM: 204391KW (B1&B2)

ASSEMBLY INSTRUCTIONS



STEP 1

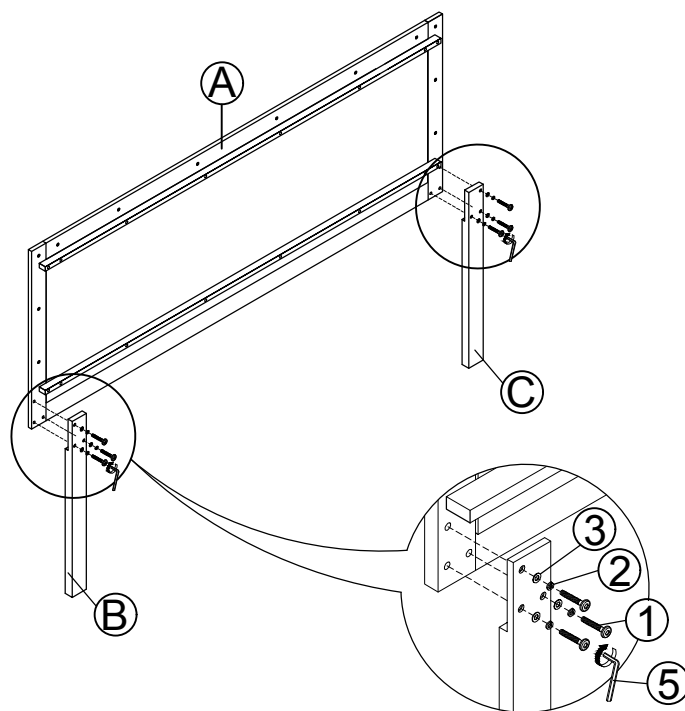

STEP 2

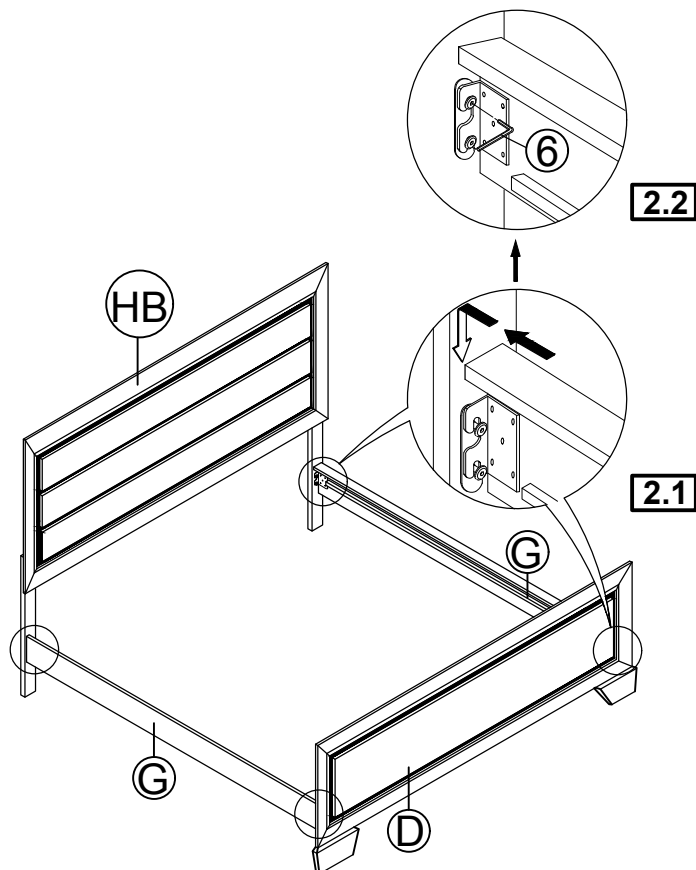

ITEM: 204391KW (B1&B2)

ASSEMBLY INSTRUCTIONS



STEP 3

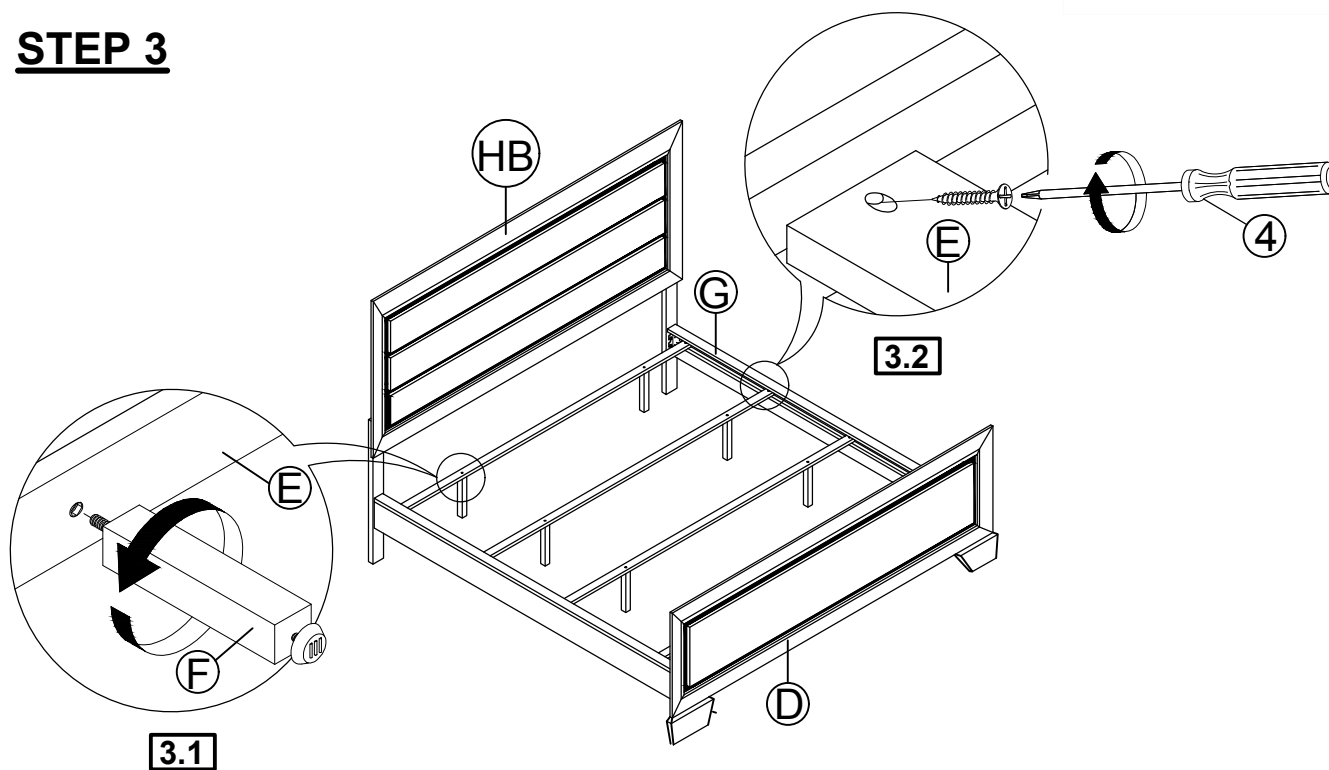

STEP 4 COMPLETE

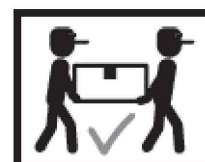
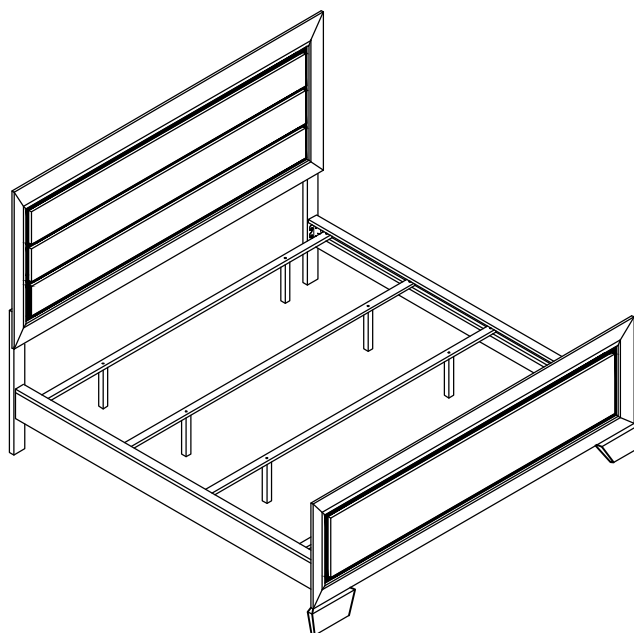

ITEM: **204391KW (B1&B2)**



Inner Size : 76.75"W X 86.50"D

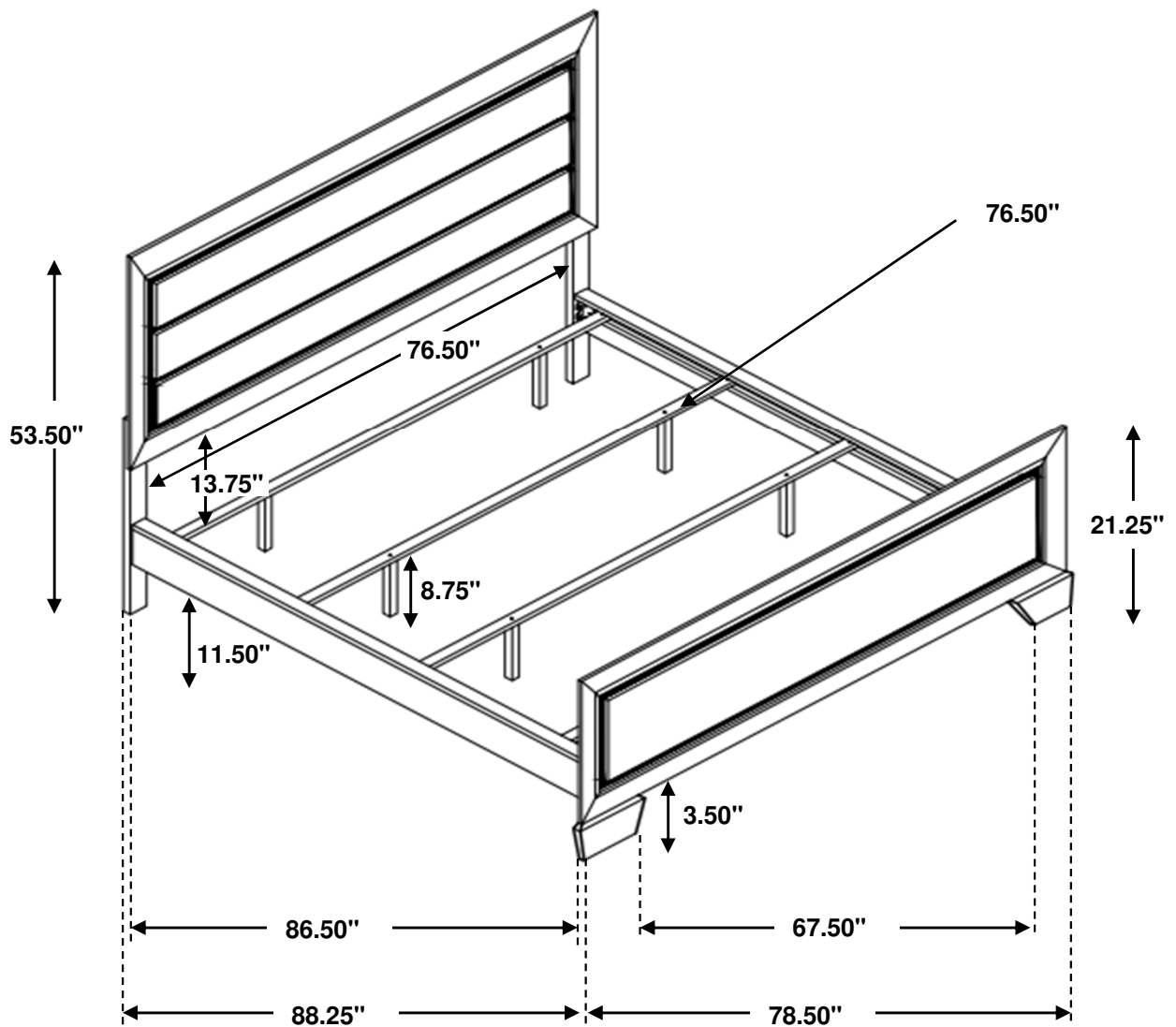

Note : Dimension tolerance $\pm 5\%$