

ASSEMBLY INSTRUCTIONS COASTER FINE FURNITURE



Fine Furniture for every stage of life

207050Q (B1&B2) **Queen Storage Bed**

ITEM: 207050Q (B1&B2)



ASSEMBLY INSTRUCTIONS

ASSEMBLY TIPS:

1. Remove hardware from box and sort by size.
2. Please check to see that all hardware and parts are present prior to start of assembly.
3. Please follow attached instructions in the same sequence as numbered to assure fast & easy assembly.



WARNING!

1. Don't attempt to repair or modify parts that are broken or defective. Please contact the store immediately.
2. This product is for home use only and not intended for commercial establishments.

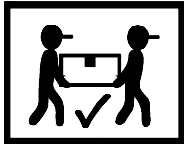

ASSEMBLY TIME

30 MINUTES

PARTS IDENTIFICATION

B1 (BOX 1)

A	HEADBOARD PANEL		4 PCS	H	BED RAIL(L&R)		2 PCS
B	LEFT HEADBOARD SUPPORT (WITH "L" LABEL)		1 PC	I	ROLL SLAT (6 PCS)		2 SETS
C	RIGHT HEADBOARD SUPPORT (WITH "R" LABEL)		1 PC	J	BED SLAT SUPPORT WITH LEVELER		4 PCS
D	CENTRE HEADBOARD SUPPORT		1 PC	K	ROLL SLAT SUPPORT RAIL		2 PCS
E	LEFT HEADBOARD LEG (WITH "L" LABEL)		1 PC	L	DRAWER FRAME		1 PC
F	RIGHT HEADBOARD LEG (WITH "R" LABEL)		1 PC	M	DRAWER FRAME SUPPORT WITH LEVELER		3 PCS
G	FOOTBOARD		1 PC	O	CONCEAL PANEL		1 PC

B2 (BOX 2)

N	DRAWER		2 PCS
---	--------	--	-------

ITEM: 207050Q (B1&B2)



ASSEMBLY INSTRUCTIONS

ASSEMBLY TIPS:

1. Remove hardware from box and sort by size.
2. Please check to see that all hardware and parts are present prior to start of assembly.
3. Please follow attached instructions in the same sequence as numbered to assure fast & easy assembly.

















WARNING!

1. Don't attempt to repair or modify parts that are broken or defective. Please contact the store immediately.
2. This product is for home use only and not intended for commercial establishments.

HARDWARE IDENTIFICATION

Z-B1 (BOX 1) - HARDWARE PACK IS LOCATED IN 207050Q (B1)

1	BOLT 1 (M8 x 20MM - RBW)		8 PCS	8	PAN HEAD SCREW (M4 x 16MM-BLK)		4 PCS
2	BOLT 2 (M8 x 35MM - RBW)		22 PCS	9	SHORT FLAT HEAD SCREW (M4 x 16MM - BLK)		4 PCS
3	BOLT 3 (M6 x 25MM - RBW)		4 PCS	10	LONG FLAT HEAD SCREW (M4 x 32MM - RBW)		26 PCS
4	BOLT 4 (M6 x 40MM - RBW)		6 PCS	11	WOOD DOWEL (M8ø x 30MM)		3 PCS
5	BOLT 5 (M6 x 50MM - RBW)		4 PCS	12	METAL BRACKET (1 x 18 x 20mm - BLK)		2 PCS
6	LOCK WASHER (5/16" x 14ø - RBW)		22 PCS	13	SMALL ALLEN WRENCH (M4 x 65mm - BLK)		1 PC
7	FLAT WASHER (5/16" x 22ø - RBW)		22 PCS	14	BIG ALLEN WRENCH (M5 x 65mm - BLK)		1 PC

NOTE:

Phillips head screw driver is required in the assembly process; however, manufacturer does not provided this item.

ITEM: 207050Q (B1&B2)

ASSEMBLY INSTRUCTIONS

STEP 1

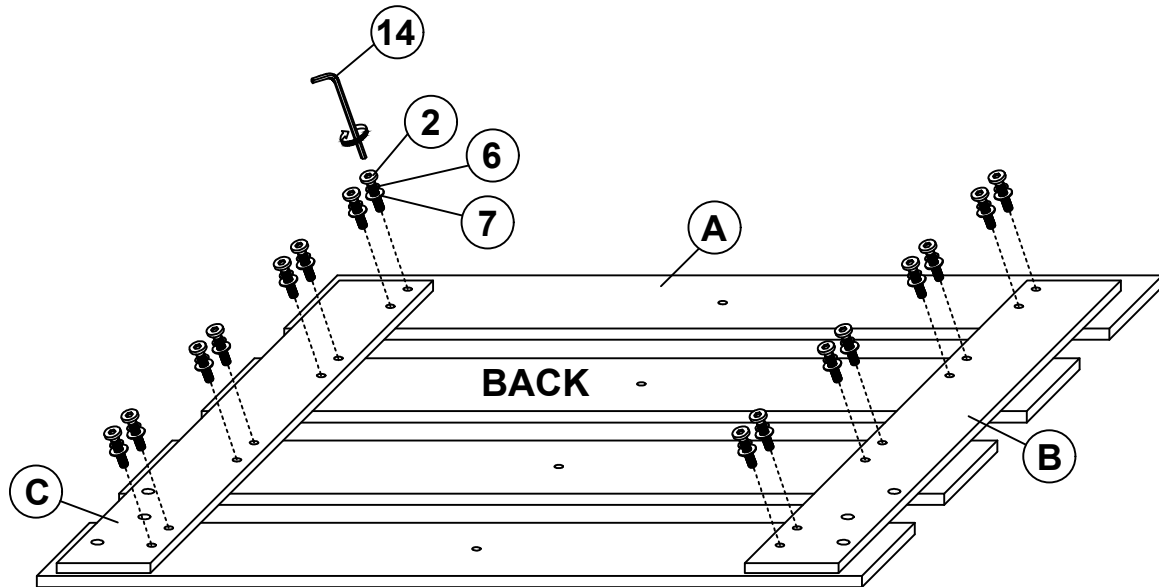

STEP 2

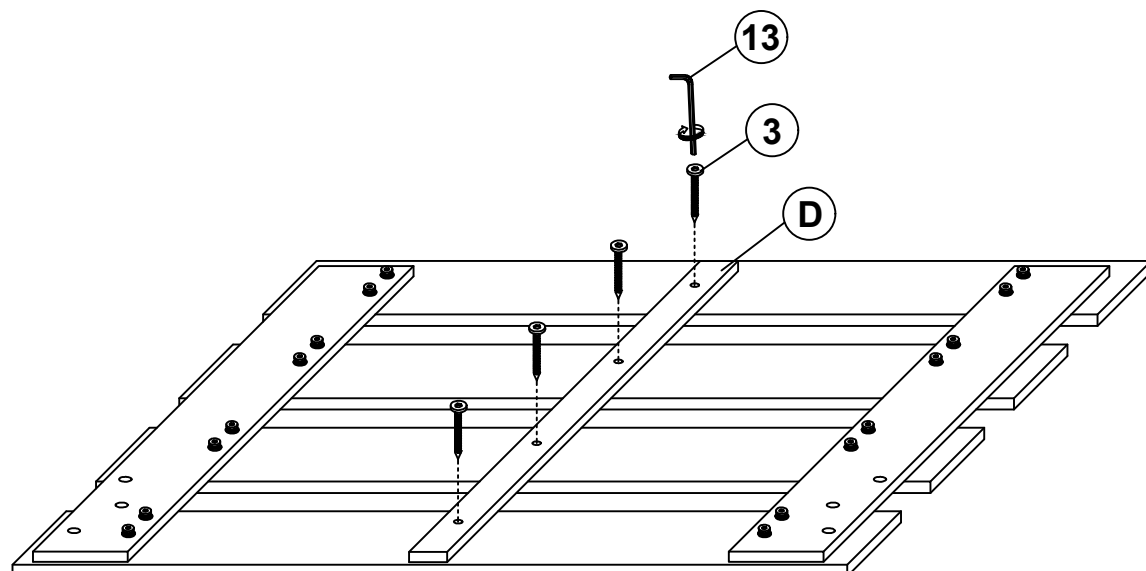

ITEM: 207050Q (B1&B2)

ASSEMBLY INSTRUCTIONS

STEP 3

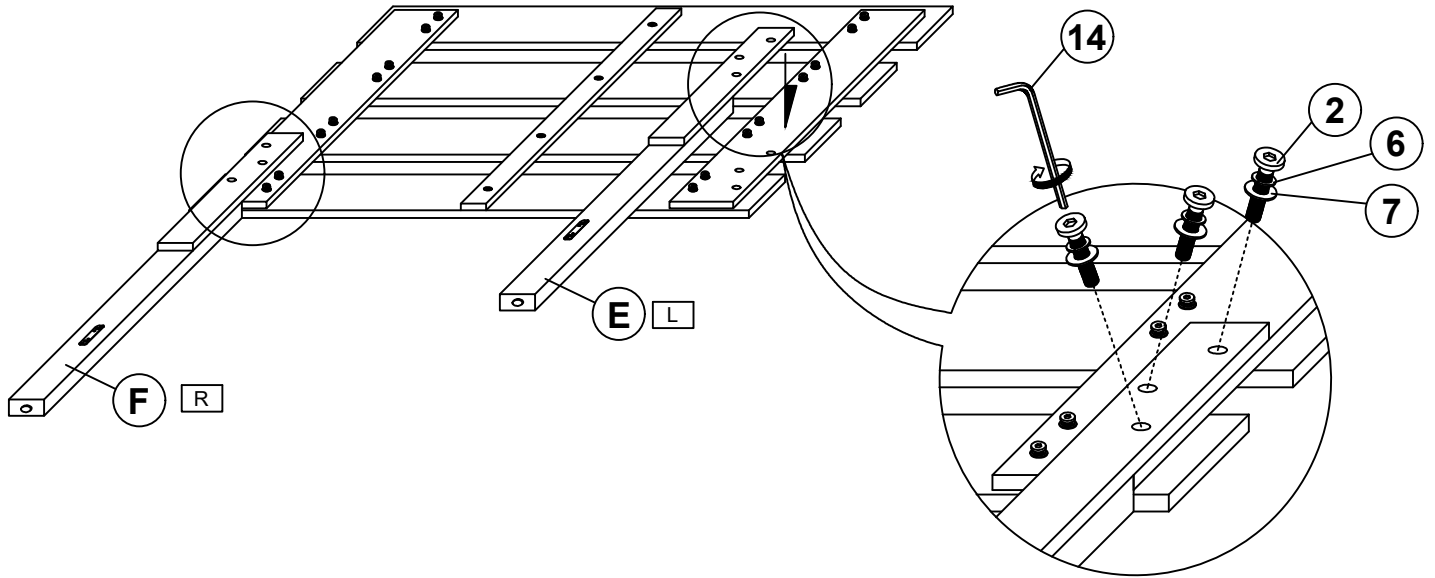

STEP 4

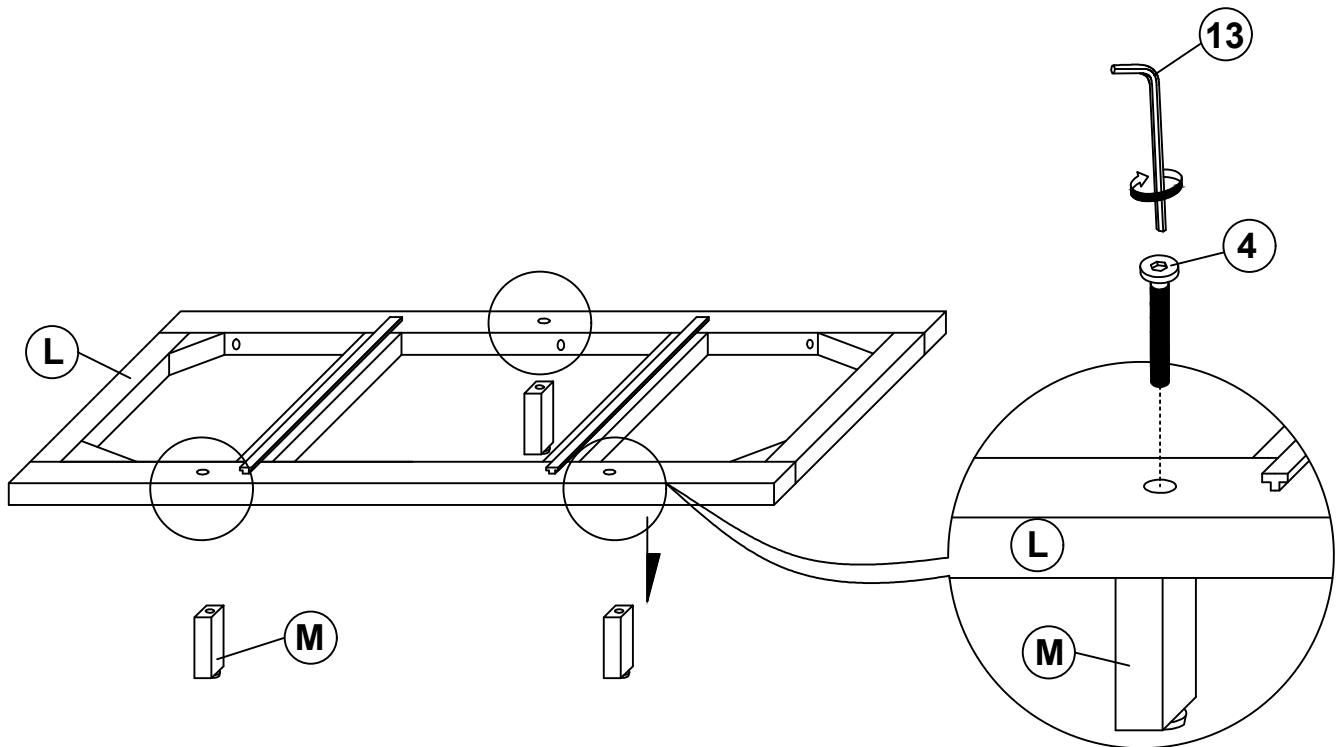

ITEM: 207050Q (B1&B2)

ASSEMBLY INSTRUCTIONS

STEP 5

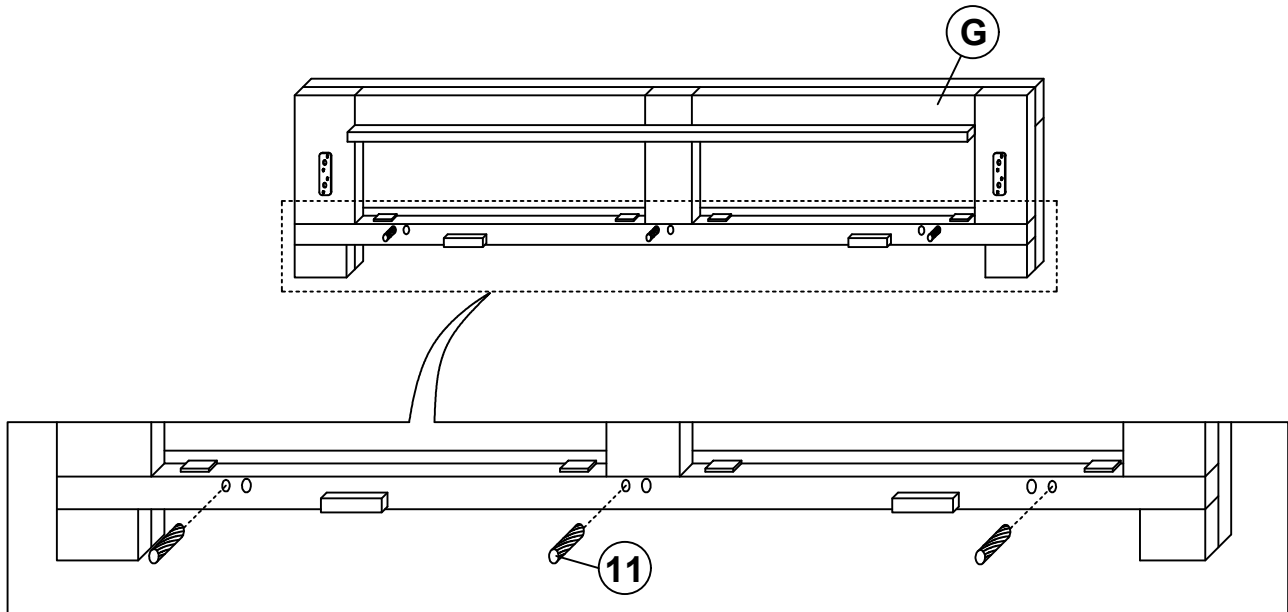

STEP 6

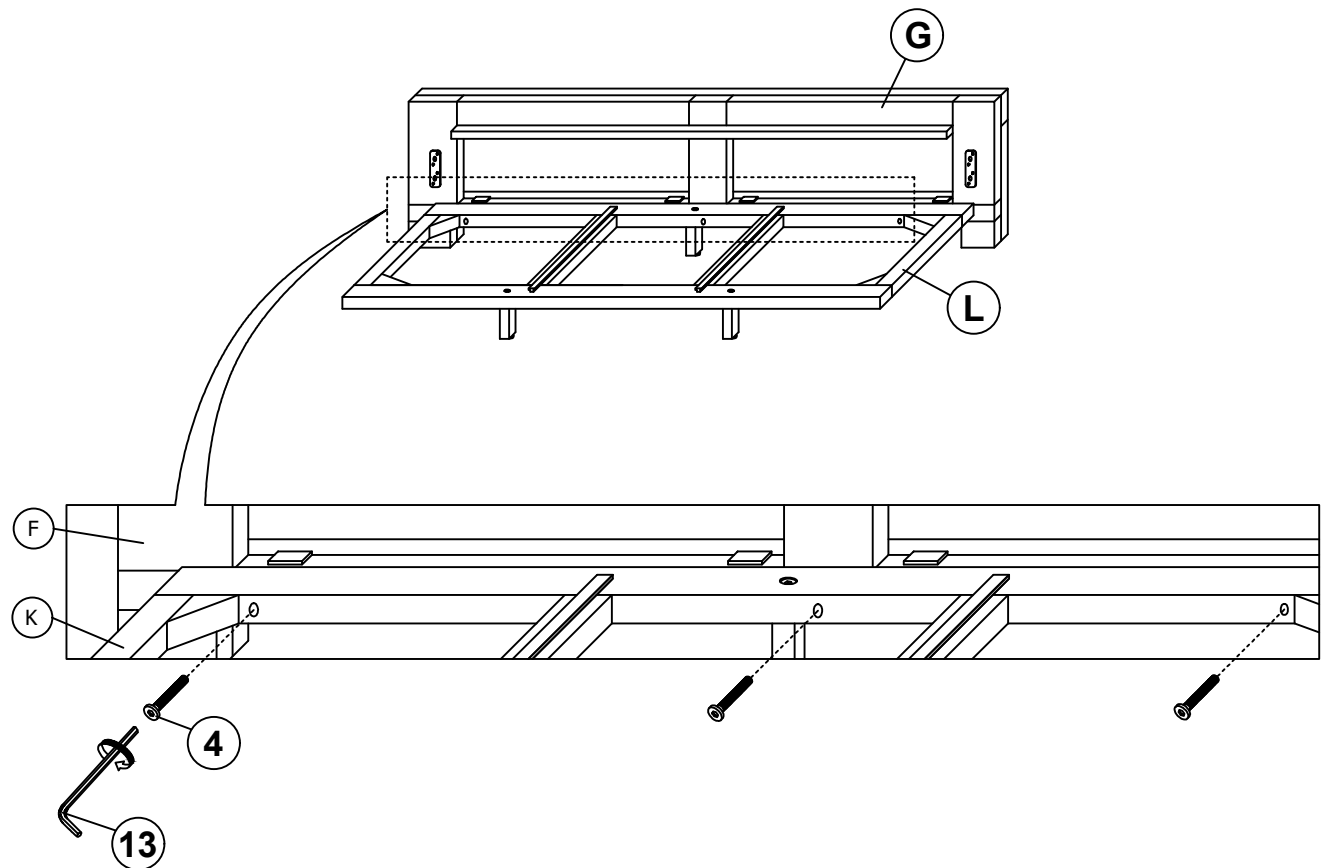

ITEM: 207050Q (B1&B2)

ASSEMBLY INSTRUCTIONS

STEP 7

THE SIDE WITH THE SMALL WOODEN BLOCK NEEDS TO FACE THE (G).

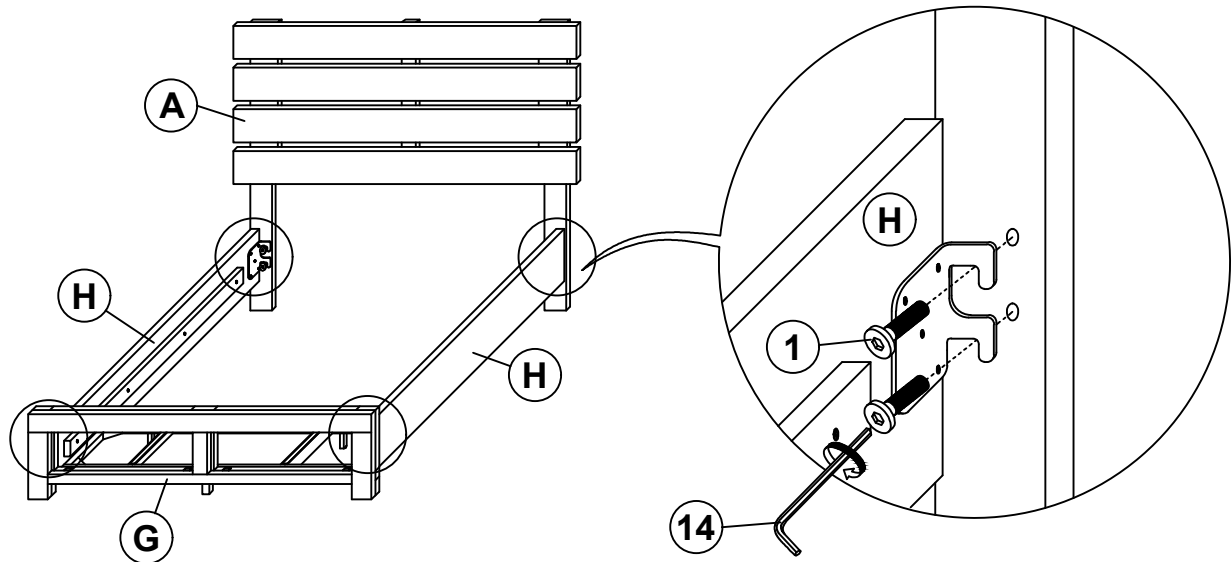
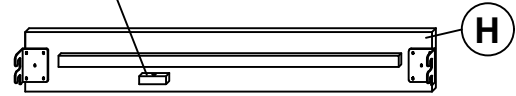

STEP 8

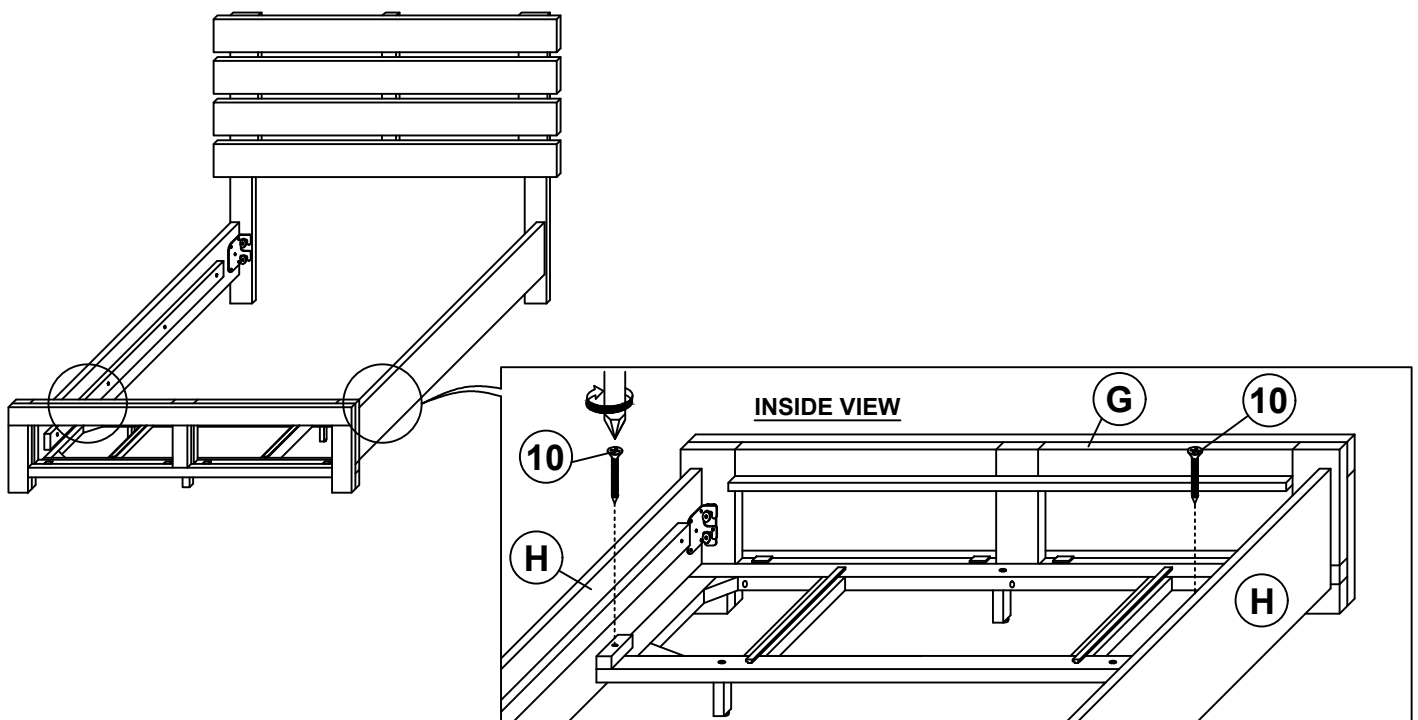

ITEM: 207050Q (B1&B2)

ASSEMBLY INSTRUCTIONS

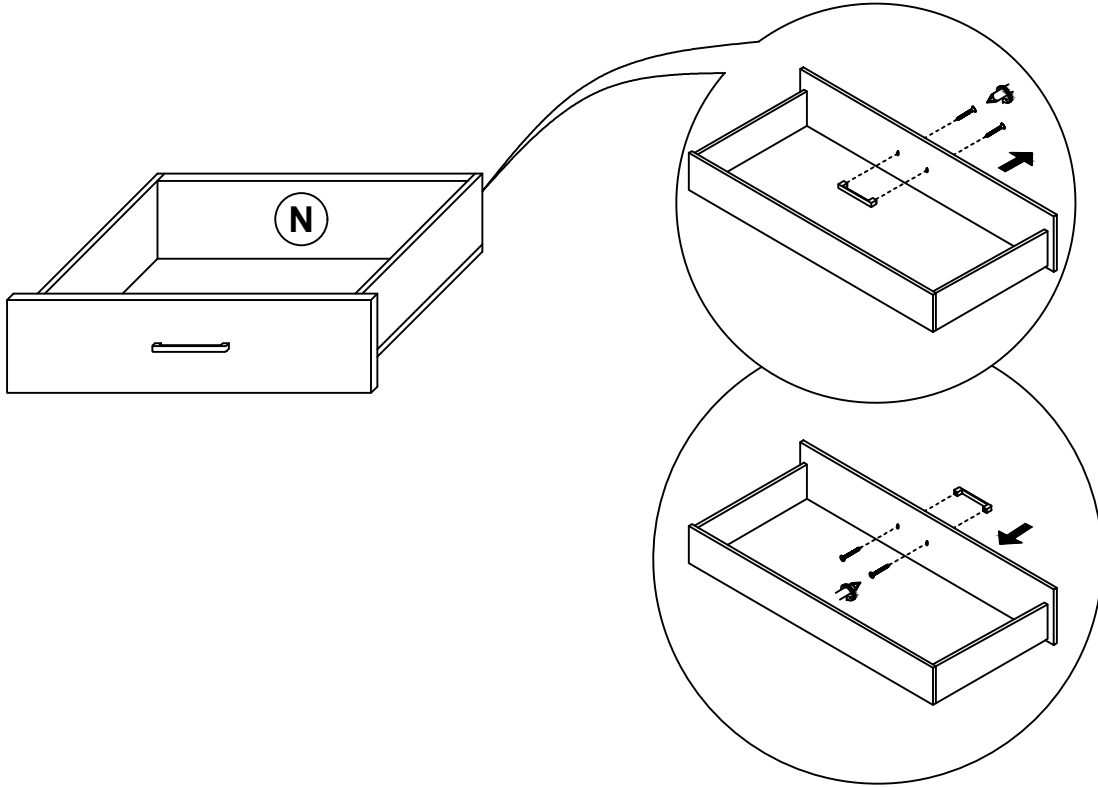

STEP 10

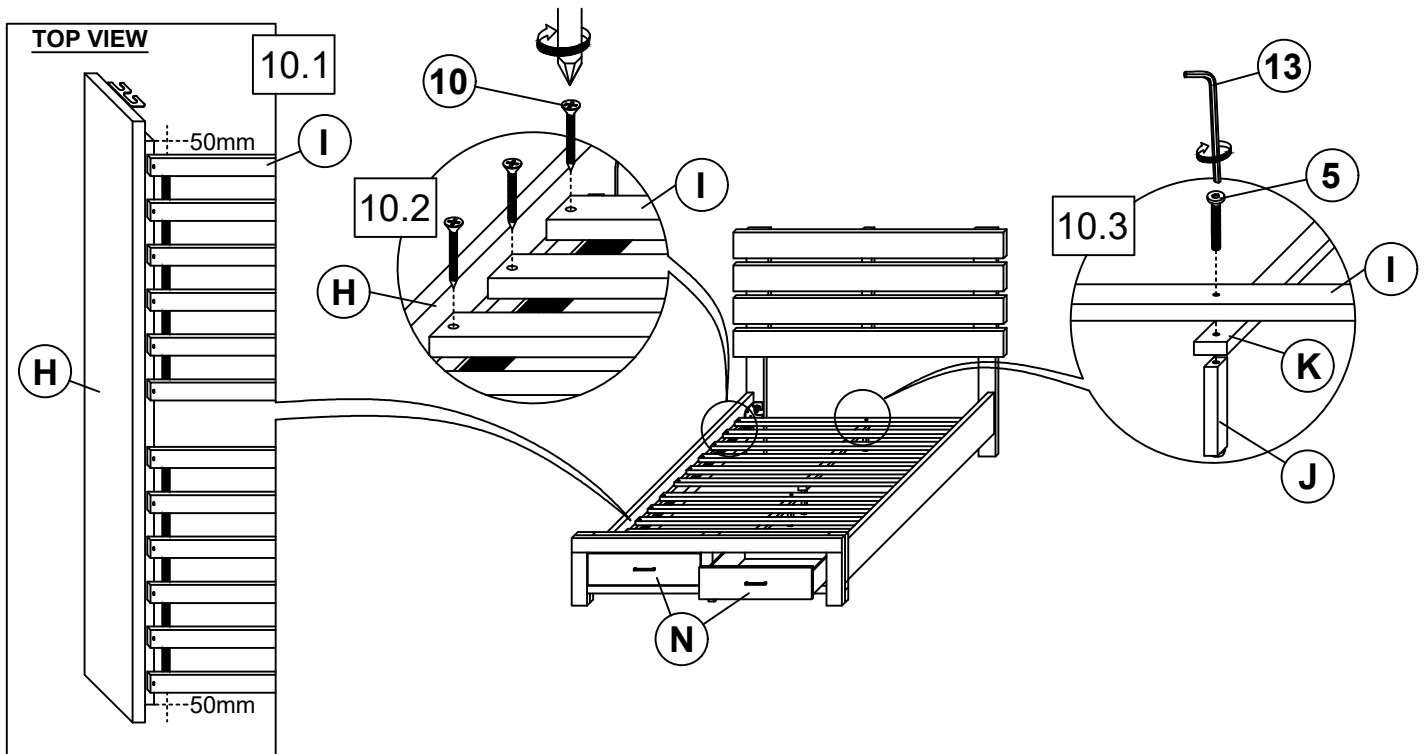

ITEM: 207050Q (B1&B2)

ASSEMBLY INSTRUCTIONS

STEP 11

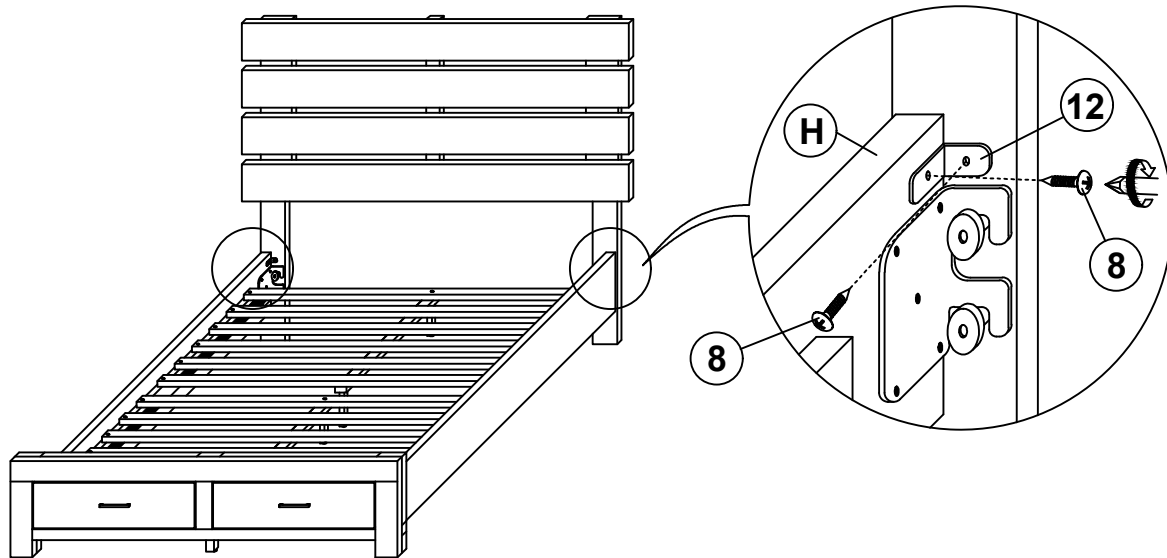

STEP 12

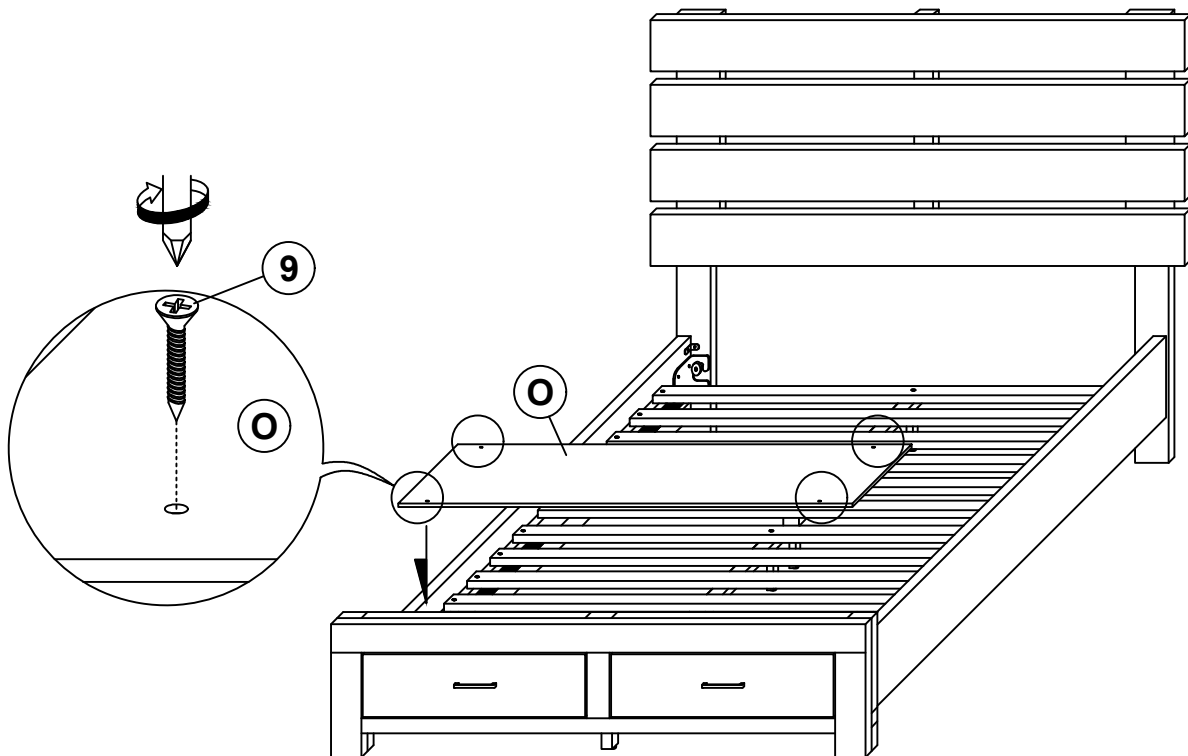

ITEM: **207050Q (B1&B2)**

ASSEMBLY INSTRUCTIONS

STEP 13

COMPLETE

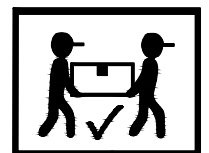
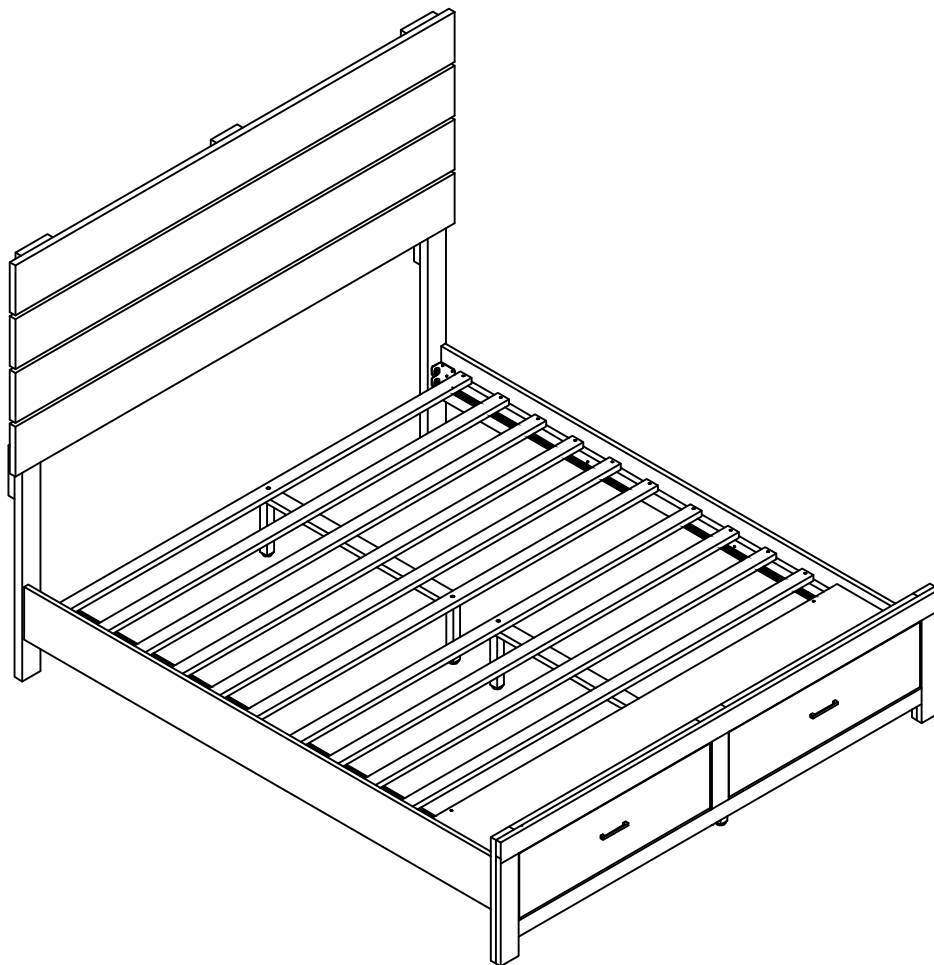

ITEM: 207050Q (B1&B2)



Inner Size : 60.75"W X 82.00"D

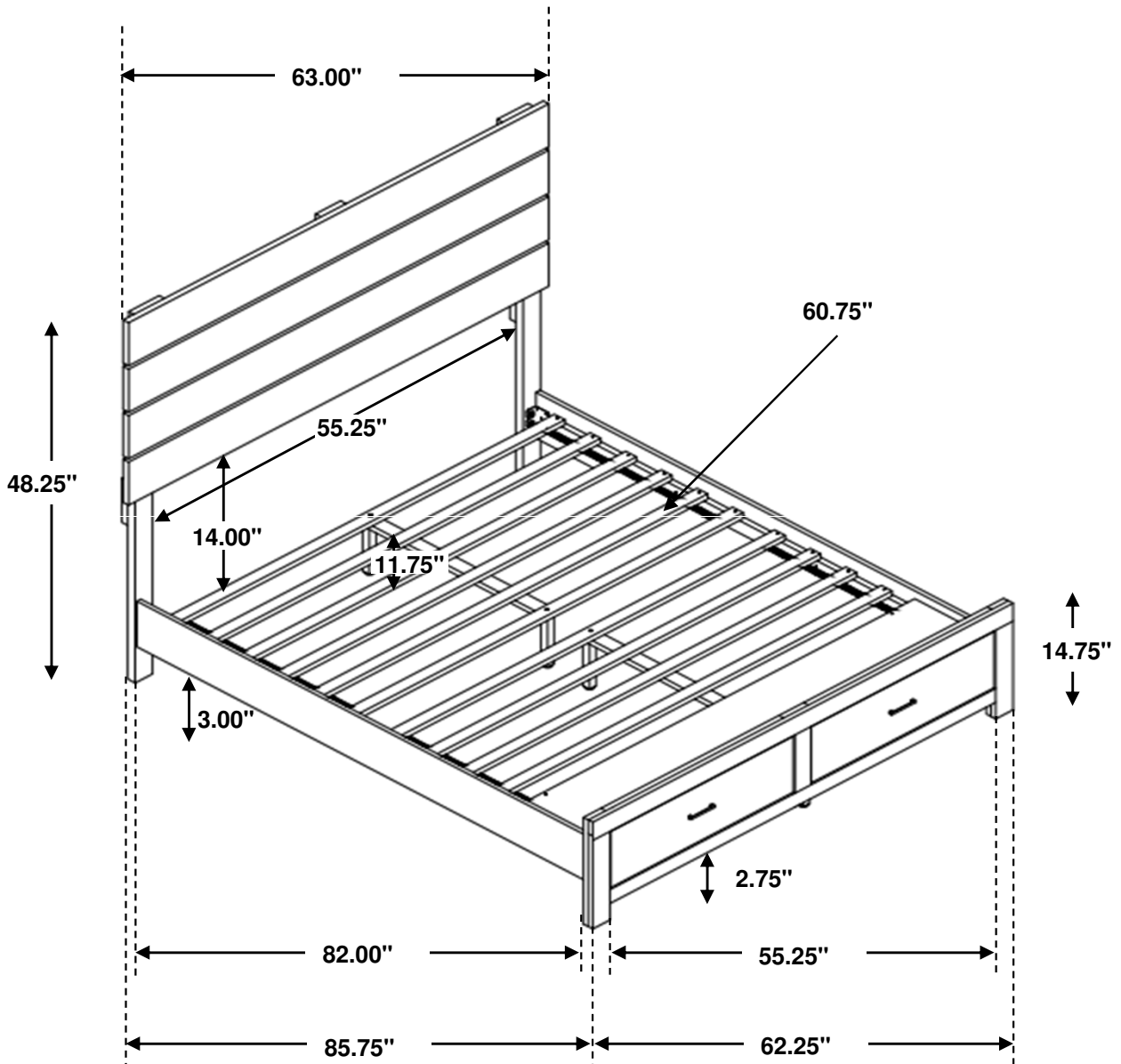

Note : Dimension tolerance $\pm 5\%$