



ASSEMBLY INSTRUCTIONS COASTER FINE FURNITURE



Fine Furniture for every stage of life

800727
OFFICE CHAIR

REIVSION:06/16/2020
REIVSION 1:2022-07-15

PAGE 1 OF 4

COASTERFURNITURE.COM

ITEM :800727
ASSEMBLY INSTRUCTIONS



ASSEMBLY TIPS:

1. Remove hardware from box and sort by size.
2. Please check to see that all hardware and parts are present prior to start of assembly.
3. Please follow attached instructions in the same sequence as numbered to assure fast & easy assembly.







Warning!

1. Don't attempt to repair or modify parts that are broken or defective. Please contact the store immediately.
2. This product is for home use only and not intended for commercial establishments.





ASSEMBLY TIME	5 MINUTES
---------------	-----------

PARTS IDENTIFICATION

	PART NAME	FIGURE	QTY
A	SEAT AND BACK		1PC
B	ADJUSTING PLATE		1PC
C	GAS CYLINDER		1PC
D	BASE		1PC
E	CASTER		5PCS

HARDWARE IDENTIFICATION

	HARDWARE NAME	FIGURE	QTY
1	BOLTS 3/16X16MM		4PCS
2	ALLEN WRENCH M6		1PC

ITEM :800727 ASSEMBLY INSTRUCTIONS

STEP 1

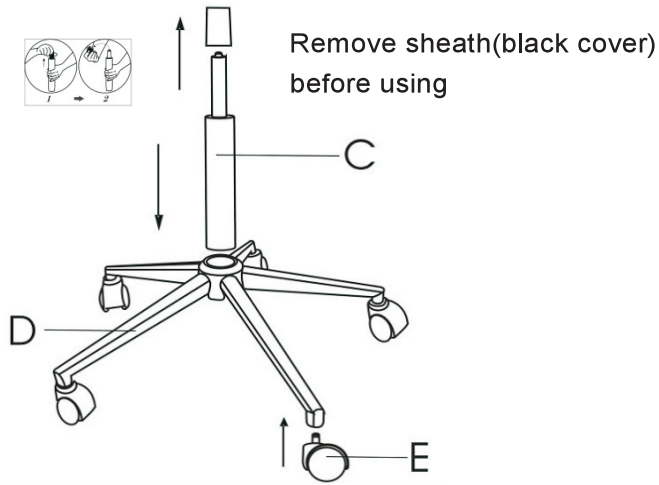

STEP 2

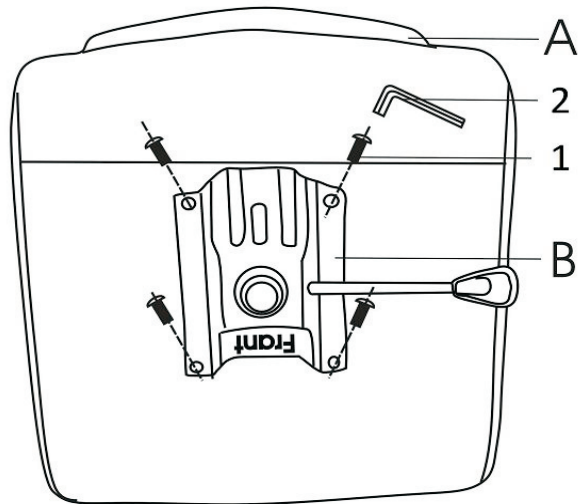

STEP 3

Firmly push top into gas spring

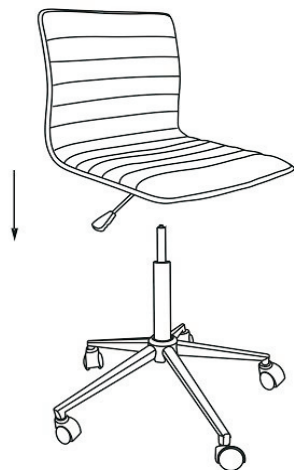

STEP 4



ITEM :800727
ASSEMBLY INSTRUCTIONS

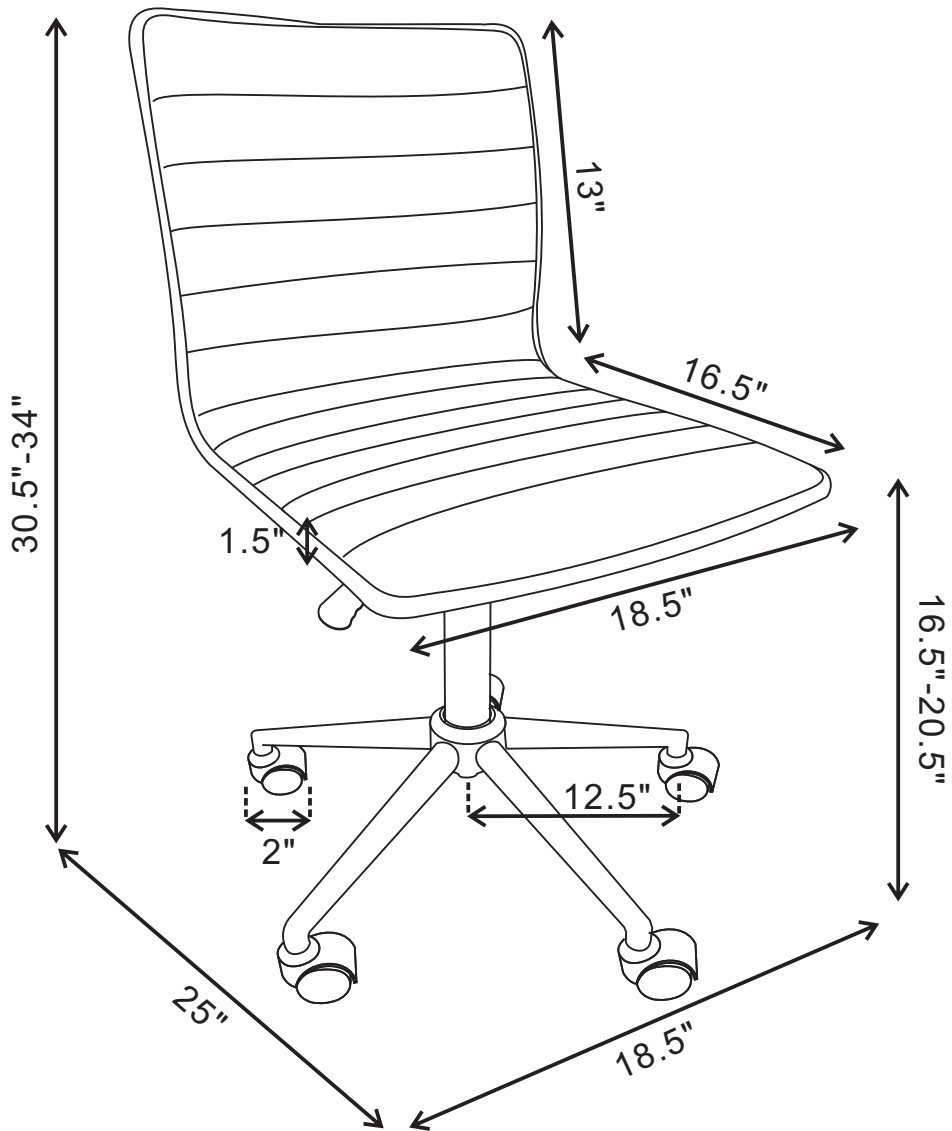

Note: Dimension tolerance $\pm 5\%$