

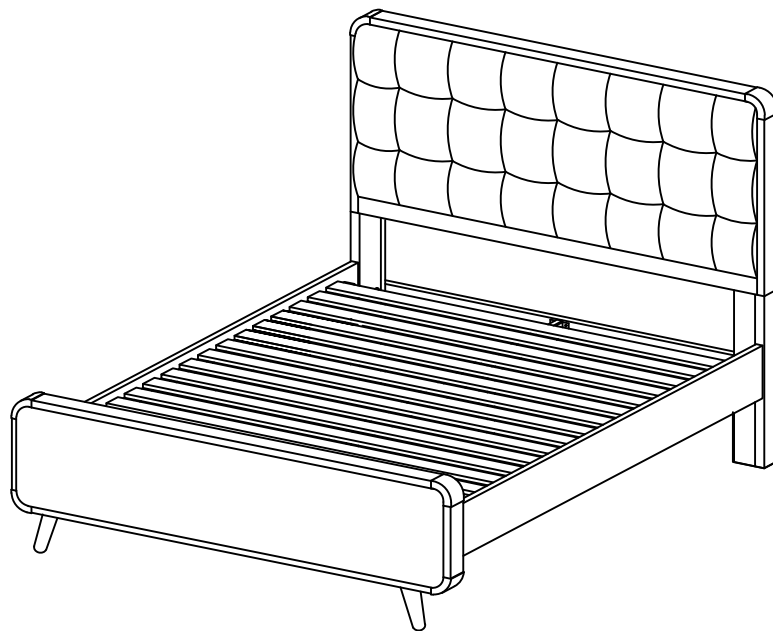

# ASSEMBLY INSTRUCTIONS COASTER FINE FURNITURE



*Fine Furniture for every stage of life*

## **205131KW (B1-B3)** ***California King Bed***

REVISION 0 : 08/17/2018  
REVISION 1 : 12/04/2019  
REVISION 2 : 08/04/2020

**PAGE 1 OF 10**

COASTERFURNITURE.COM

# ITEM: 205131KW (B1-B3)



## ASSEMBLY INSTRUCTIONS

### ASSEMBLY TIPS:

1. Remove hardware from box and sort by size.
2. Please check to see that all hardware and parts are present prior to start of assembly.
3. Please follow attached instructions in the same sequence as numbered to assure fast & easy assembly.



### WARNING!

1. Don't attempt to repair or modify parts that are broken or defective. Please contact the store immediately.
2. This product is for home use only and not intended for commercial establishments.

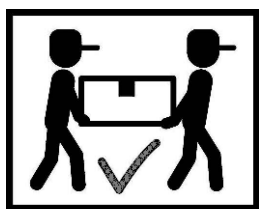

ASSEMBLY TIME

35 MINUTES

## PARTS IDENTIFICATION

### B1 ( BOX 1 )

AM HEADBOARD PANEL

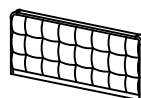

1PC

BM LEFT HEADBOARD LEG



1PC

CM RIGHT HEADBOARD LEG



1PC

DM HEADBOARD BOTTOM RAIL



1PC

### B2 ( BOX 2 )

EM FOOTBOARD PANEL



1PC

FM FOOTBOARD LEG



2PCS

### B3 ( BOX 3 )

GM BED RAIL



2PCS

HM CENTER RAIL

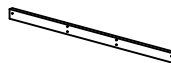

1PC

IM CENTER RAIL SUPPORT WITH LEVELER



2PCS

JM ROLL SLAT (7PCS)

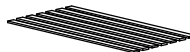

2SETS

KM BED SLAT SUPPORT WITH LEVELER



8PCS

LM RAIL TOP

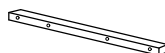

2PCS

MM BED SLAT



1PC

# ITEM: 205131KW (B1-B3)



## ASSEMBLY INSTRUCTIONS

### ASSEMBLY TIPS:

1. Remove hardware from box and sort by size.
2. Please check to see that all hardware and parts are present prior to start of assembly.
3. Please follow attached instructions in the same sequence as numbered to assure fast & easy assembly.



### WARNING!

1. Don't attempt to repair or modify parts that are broken or defective. Please contact the store immediately.
2. This product is for home use only and not intended for commercial establishments.

**HB**      **205131KW (B1)**  
**FROM BOX 1**  
**HEADBOARD COMPLETE**

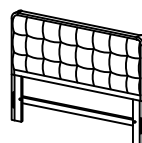

**1PC**

**FB**      **205131KW (B2)**  
**FROM BOX 2**  
**FOOTBOARD COMPLETE**



**1PC**

# ITEM: 205131KW (B1-B3)



## ASSEMBLY INSTRUCTIONS

### ASSEMBLY TIPS:

1. Remove hardware from box and sort by size.
2. Please check to see that all hardware and parts are present prior to start of assembly.
3. Please follow attached instructions in the same sequence as numbered to assure fast & easy assembly.









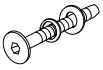
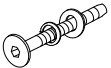

### WARNING!

1. Don't attempt to repair or modify parts that are broken or defective. Please contact the store immediately.
2. This product is for home use only and not intended for commercial establishments.

## HARDWARE IDENTIFICATION

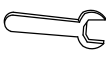
### Z-B3 (BOX 3) - HARDWARE PACK IS LOCATED IN 205131KW (B3)

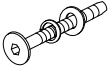
1	<b>ALLEN WRENCH</b> (M4 x 110mm - BLK)		1PC
2	<b>SHORT BOLT WITH BIG WASHER</b> (M6 x 25mm - BLK)		8PCS
3	<b>MEDIUM BOLT WITH BIG WASHER</b> (M6 x 45mm - BLK)		12PCS
4	<b>LONG BOLT WITH BIG WASHER</b> (M6 x 60mm - BLK)		4PCS
5	<b>SHORT FLAT HEAD SCREW</b> (M4 x 20mm - BLK)		8PCS
6	<b>LONG FLAT HEAD SCREW</b> (#8 x 1 1/8" - BLK)		30PCS
7	<b>HEX NUT</b> (M6 - RBW)		2PCS
8	<b>U BRACKET</b> (26 x 63 x 70mm - RBW)		2PCS
9	<b>WRENCH</b> (2 x 24.5 x 85 - RBW)		1PC
10	<b>WOOD DOWEL</b> (M8 x 30mm)		8PCS
11	<b>LONG BOLT WITH SMALL WASHER</b> (M6 x 60mm-BLK)		8PCS

### NOTE:

Phillips head screw driver is required in the assembly process; however, manufacturer does not provide this item.

ITEM: **205131KW (B1-B3)**



## ASSEMBLY INSTRUCTIONS

### STEP 1

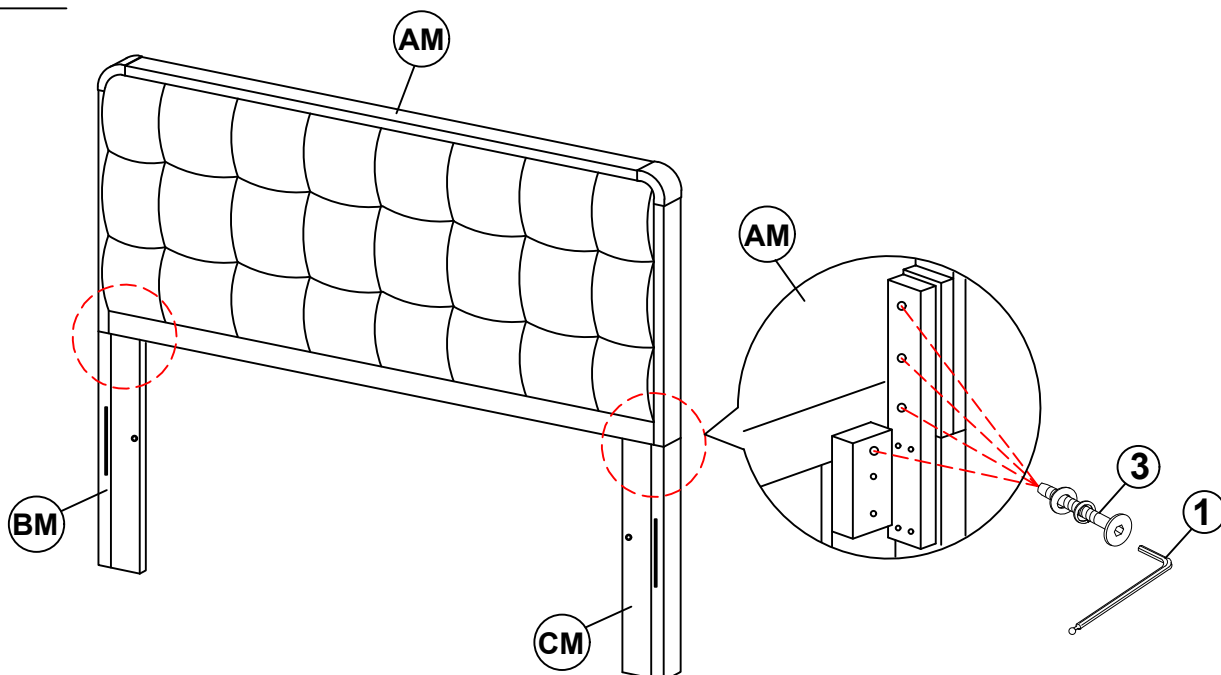

### STEP 2

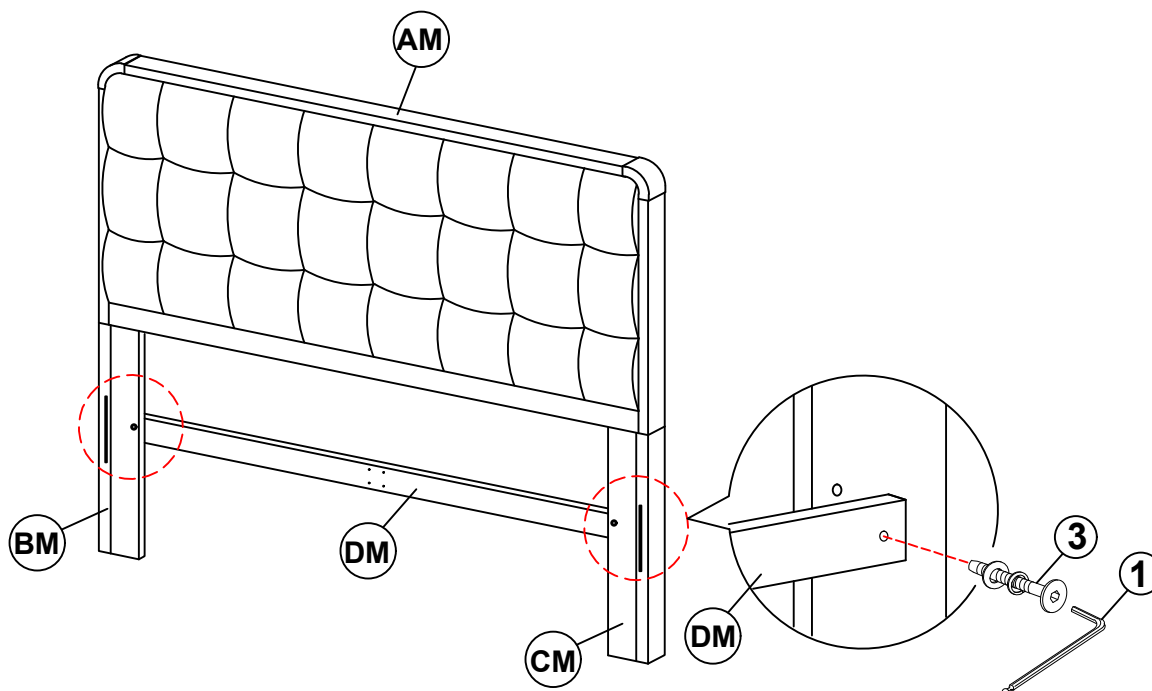

ITEM: **205131KW (B1-B3)**

**ASSEMBLY INSTRUCTIONS**  
**STEP 3**

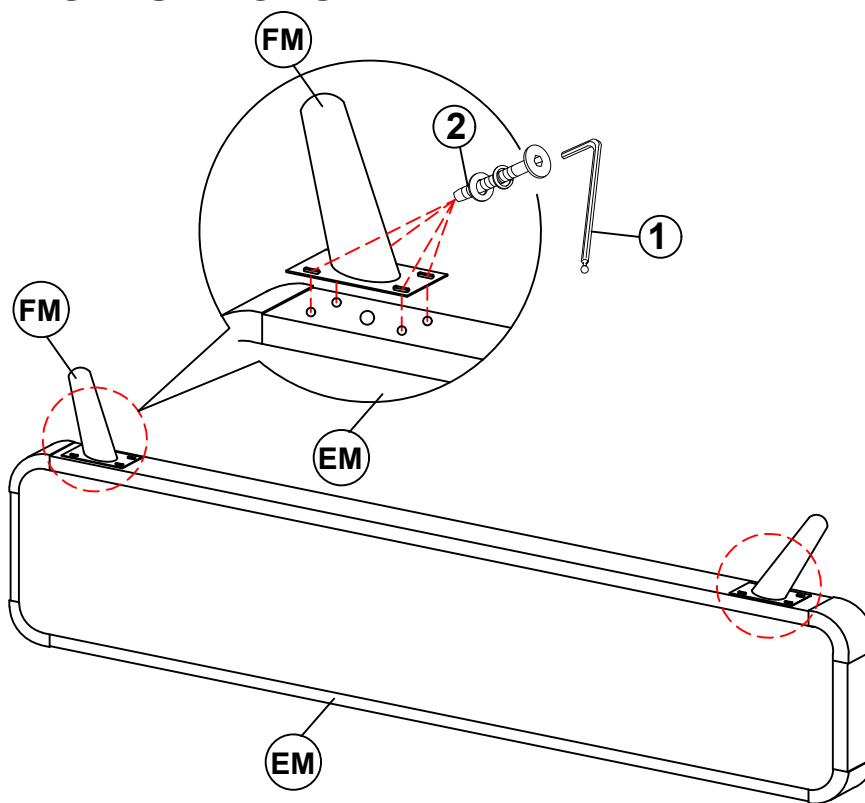

**STEP 4**

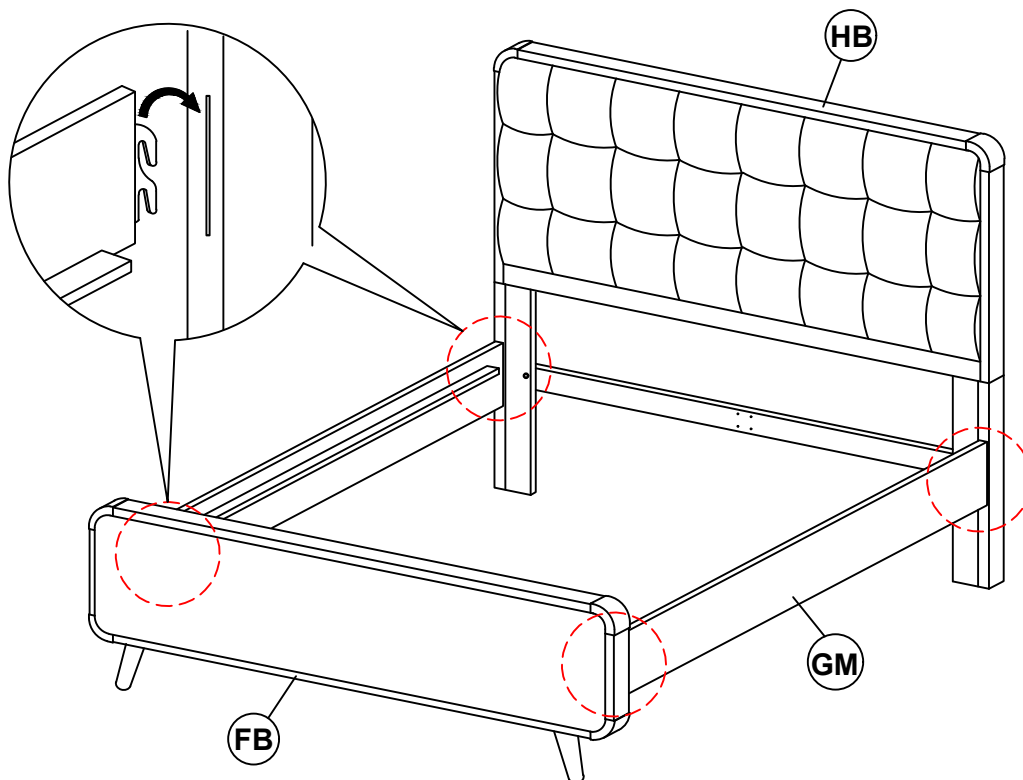

# ITEM: 205131KW (B1-B3)



## ASSEMBLY INSTRUCTIONS STEP 5

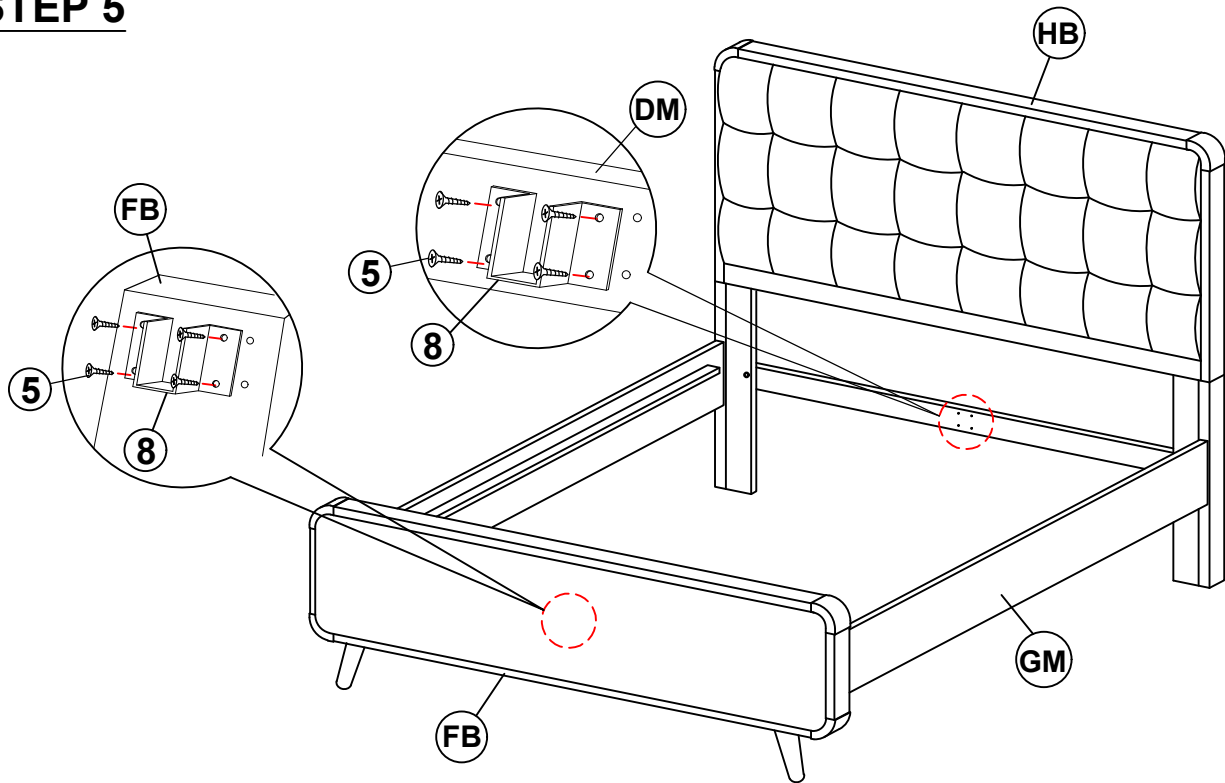

## STEP 6

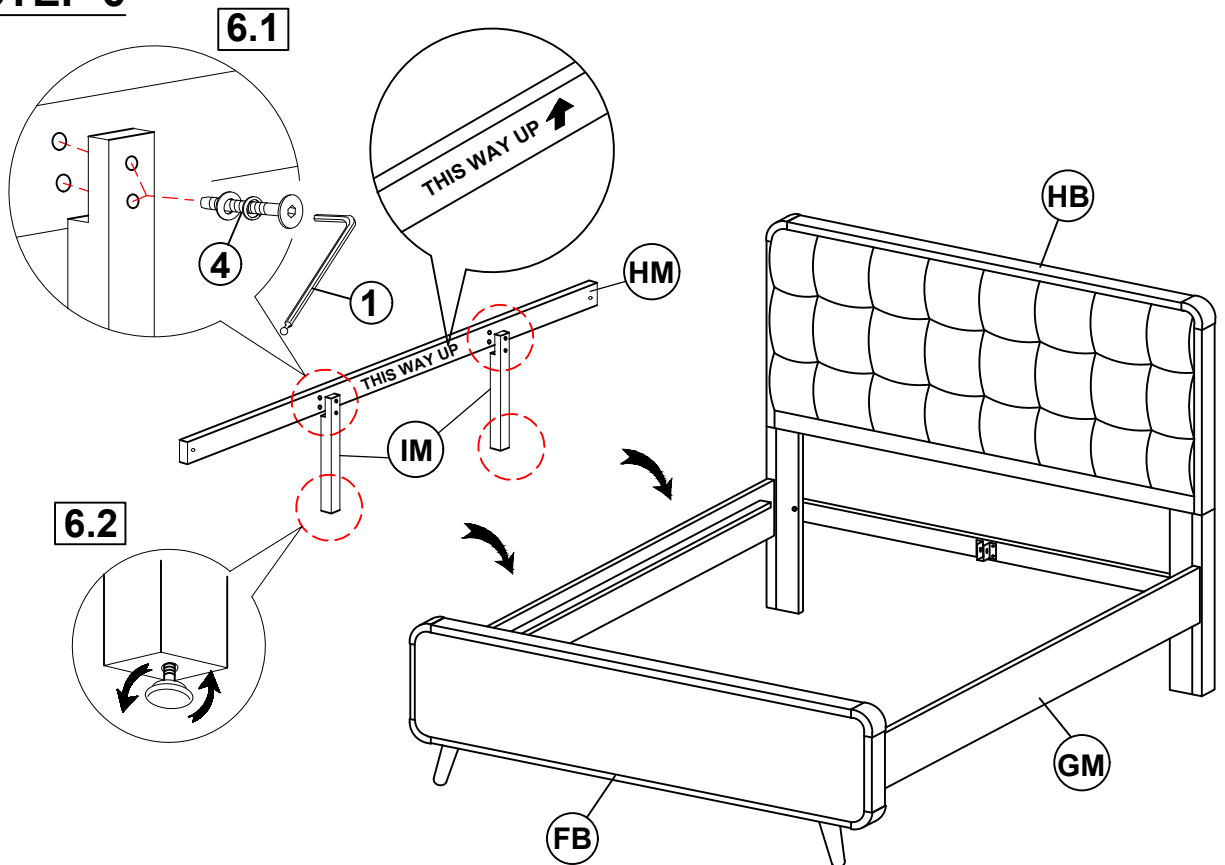

ITEM: **205131KW (B1-B3)**



**ASSEMBLY INSTRUCTIONS**  
**STEP 7**

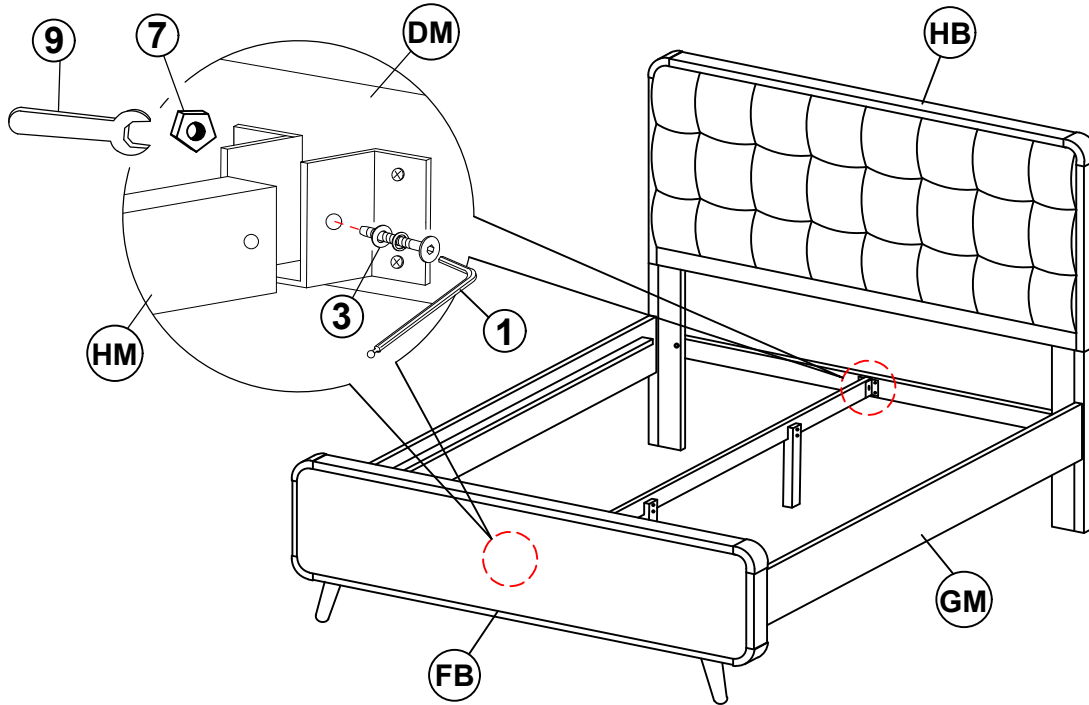

**STEP 8**

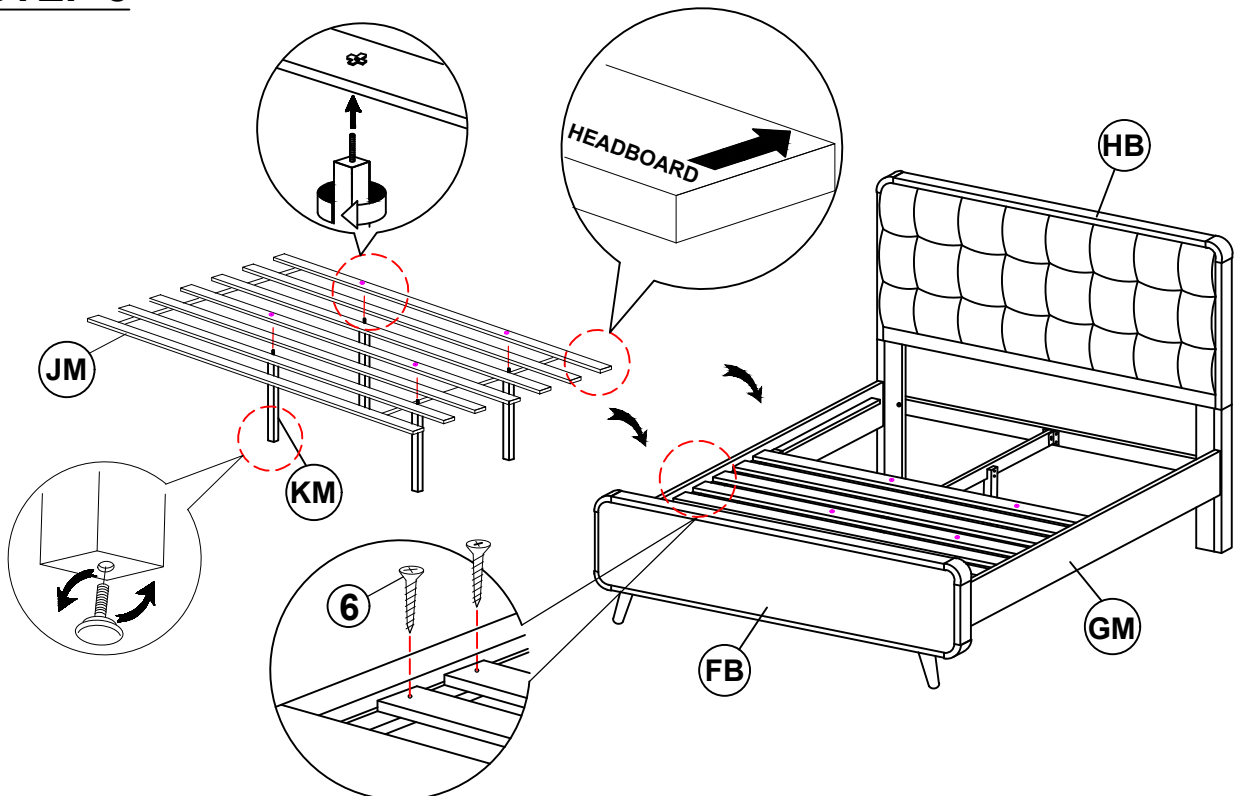



ITEM: **205131KW (B1-B3)**



**ASSEMBLY INSTRUCTIONS**  
**STEP 9**

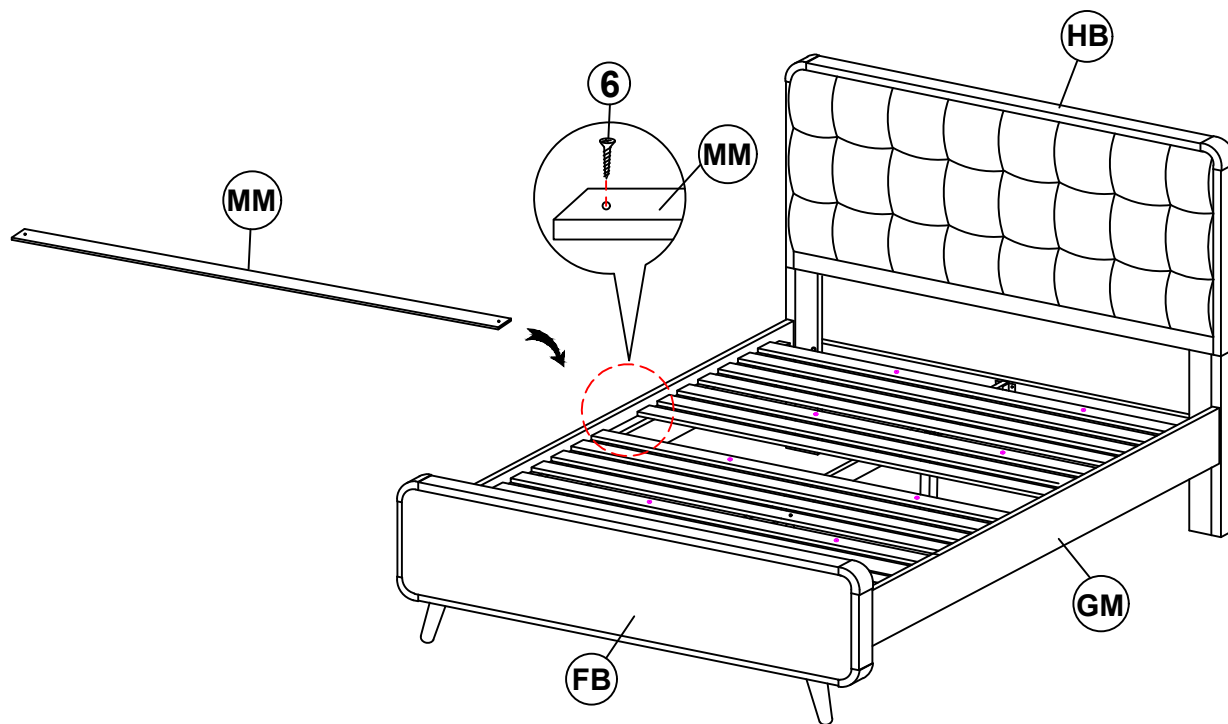

**STEP 10**

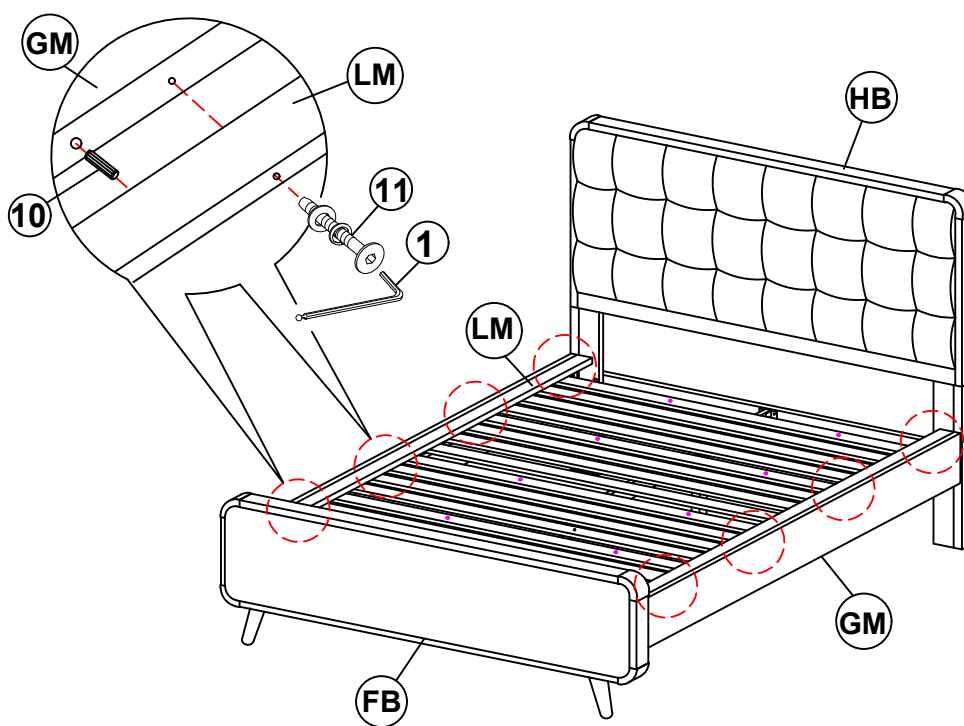

ITEM: **205131KW (B1-B3)**



**ASSEMBLY INSTRUCTIONS**

**STEP 11**

**COMPLETE**

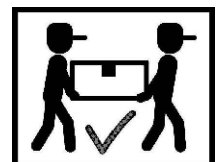
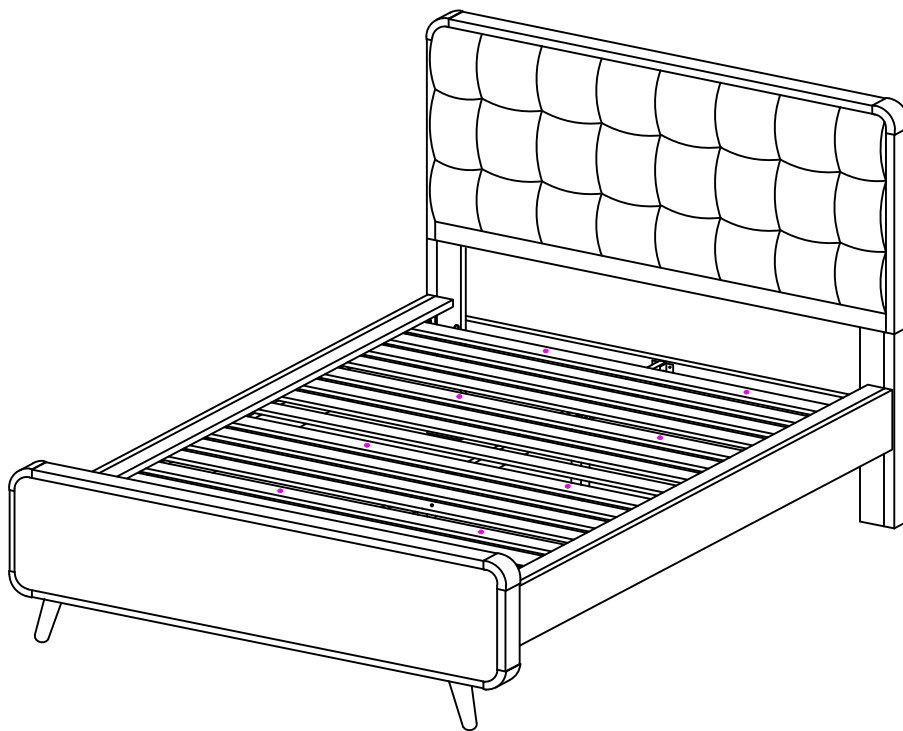

ITEM: **205131KW (B1-B3)**



Inner Size : 72.00"W x 85.00"D

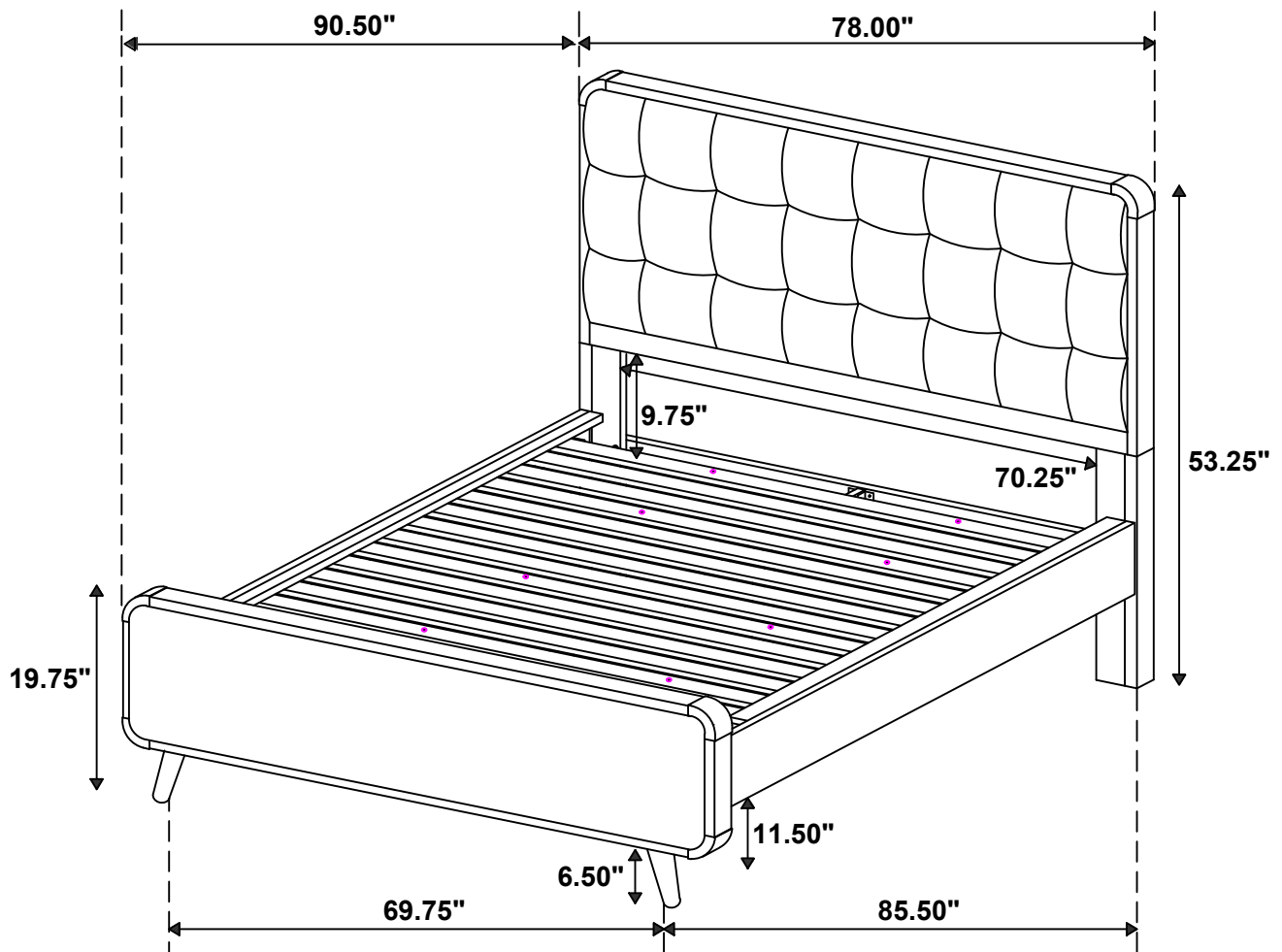

Note: Dimension tolerance  $\pm 5\%$