

ASSEMBLY INSTRUCTIONS
COASTER FINE FURNITURE



Fine Furniture for every stage of life

881291(B1&B2)
Executive Desk

ITEM: 881291(B1&B2)



ASSEMBLY INSTRUCTIONS

ASSEMBLY TIPS:

1. Remove hardware from box and sort by size.
2. Please check to see that all hardware and parts are present prior to start of assembly.
3. Please follow attached instructions in the same sequence as numbered to assure fast & easy assembly.



WARNING!

1. Don't attempt to repair or modify parts that are broken or defective. Please contact the store immediately.
2. This product is for home use only and not intended for commercial establishments.



ASSEMBLY TIME

30 MINUTES

PARTS IDENTIFICATION

B1 (BOX 1)

A TOP

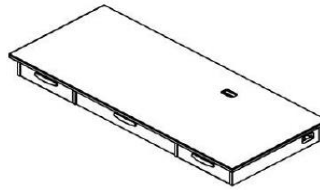

1PC

B SMALL DRAWER DIVIDER



4PCS

B2 (BOX 2)

C LEFT COMPARTMENT

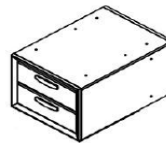

1PC

D RIGHT COMPARTMENT

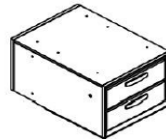

1PC

E CENTER PANEL

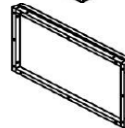

1PC

F METAL LEG FRAME WITH LEVELER

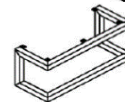

2PCS

G DRAWER HANGER



2PCS

H BIG DRAWER DIVIDER



2PCS

I UNIVERSAL KEY



2SETS

ITEM: 881291 (B1 & B2)



ASSEMBLY INSTRUCTIONS

ASSEMBLY TIPS:

1. Remove hardware from box and sort by size.
2. Please check to see that all hardware and parts are present prior to start of assembly.
3. Please follow attached instructions in the same sequence as numbered to assure fast & easy assembly.



WARNING!

1. Don't attempt to repair or modify parts that are broken or defective. Please contact the store immediately.
2. This product is for home use only and not intended for commercial establishments.









ASSEMBLY TIME

30 MINUTES

HARDWARE IDENTIFICATION

Z-B2 (BOX 2) - HARDWARE PACK IS LOCATED IN 881291 (B2)

1	LONG BOLT (M6 x 45mm - BLK)		10PCS
2	MEDIUM BOLT (M6 x 35mm - BLK)		4PCS
3	SHORT BOLT (M6 x 25mm - BLK)		10PCS
4	LOCK WASHER (1.6 x 12mm - BLK)		24PCS
5	FLAT WASHER (1.2 x 18mm - BLK)		24PCS
6	ALLEN WRENCH (M4 x 65mm - BLK)		1PC
7	WOOD DOWEL (10 x 30mm - BRW)		4PCS

ITEM: **881291(B1&B2)**



ASSEMBLY INSTRUCTIONS
STEP 1

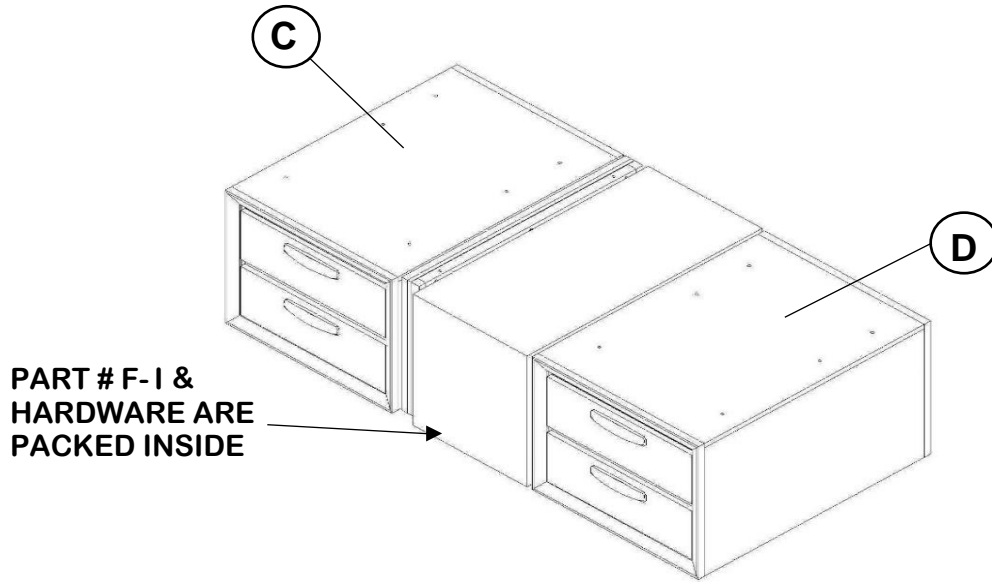

STEP 2

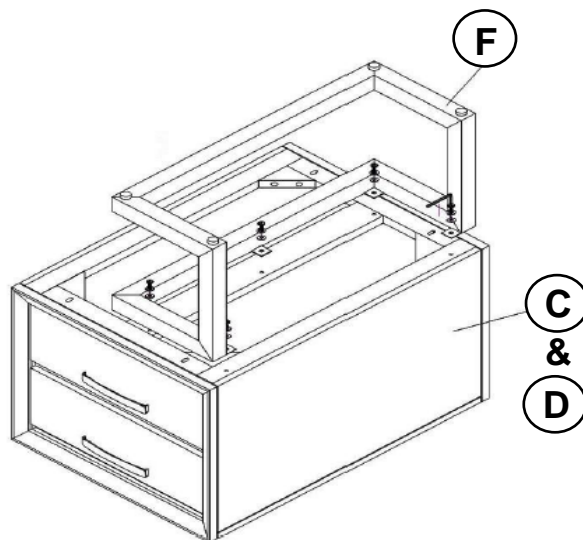
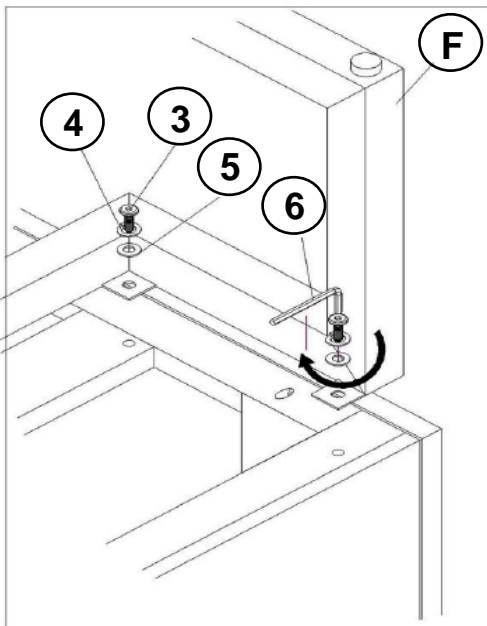

ITEM: **881291(B1&B2)**



ASSEMBLY INSTRUCTIONS
STEP 3

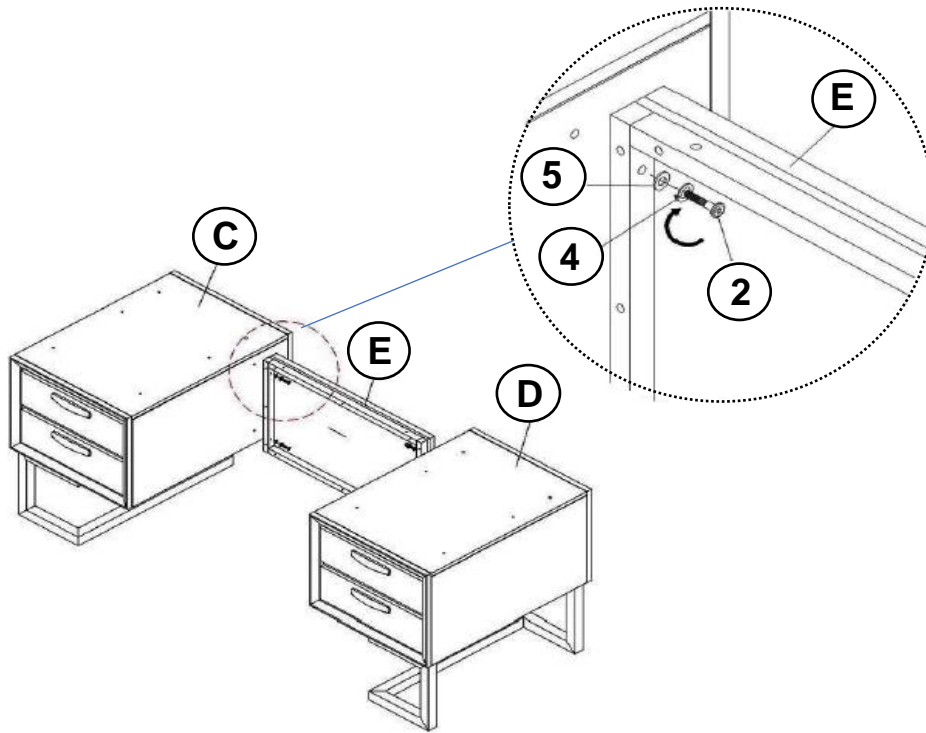

STEP 4

REMOVE DRAWERS BEFORE ATTACH TO TOP

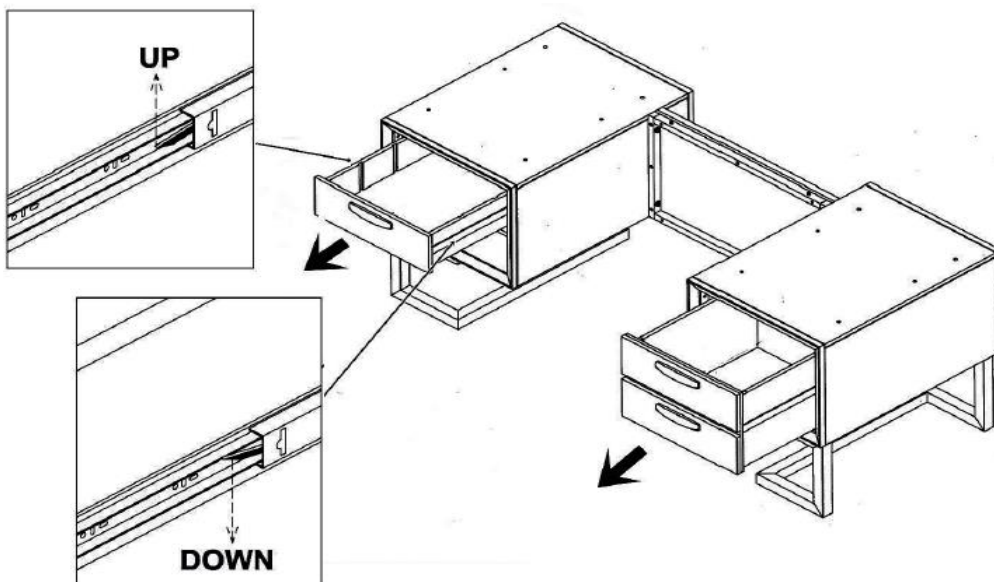

ASSEMBLY INSTRUCTIONS
STEP 5

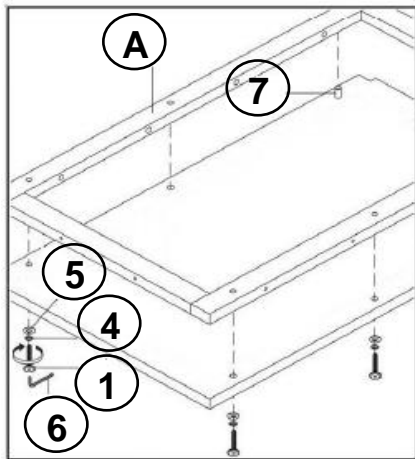

5.2

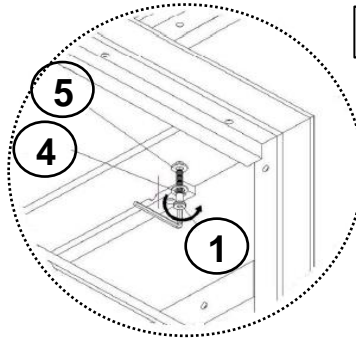

5.1

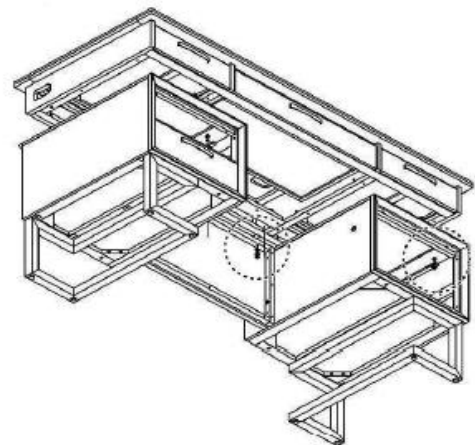
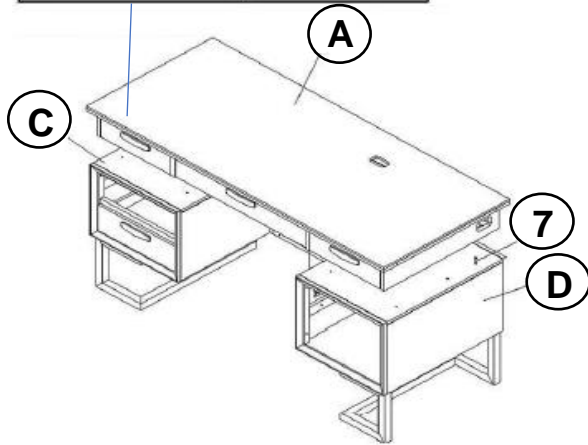

BOTTOM VIEW

STEP 6

PUT DRAWERS BACK

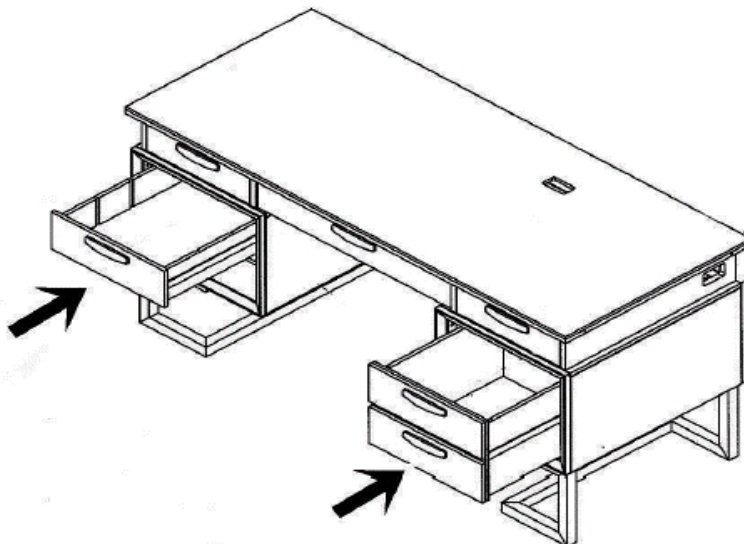

ITEM: **881291(B1&B2)**



ASSEMBLY INSTRUCTIONS
STEP 7

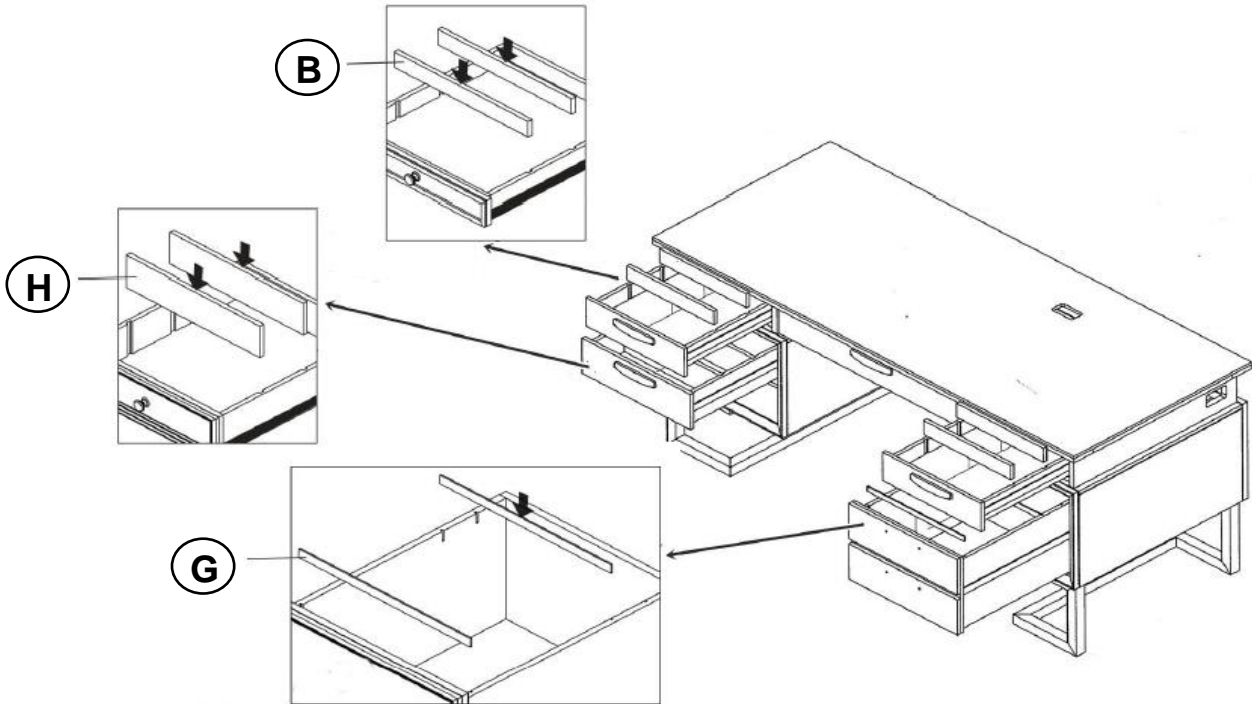

STEP 8
COMPLETE

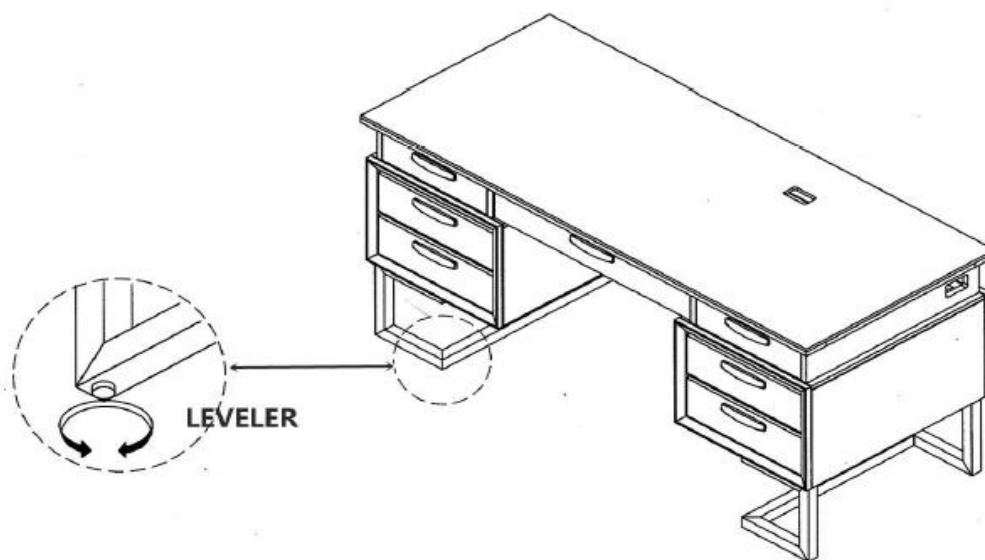

ITEM: 881291 (B1&B2)



Inner Size of Drawer A : 13.25"W X 17.75"D X 2.00"H X 0.50"T

Inner Size of Drawer B : 14.75"W X 17.75"D X 3.75"H X 0.50"T

Inner Size of Drawer C : 14.75"W X 17.75"D X 9.75"H X 0.50"T

Inner Size of Drawer D : 27.00"W X 13.00"D X 2.00"H X 0.50"T

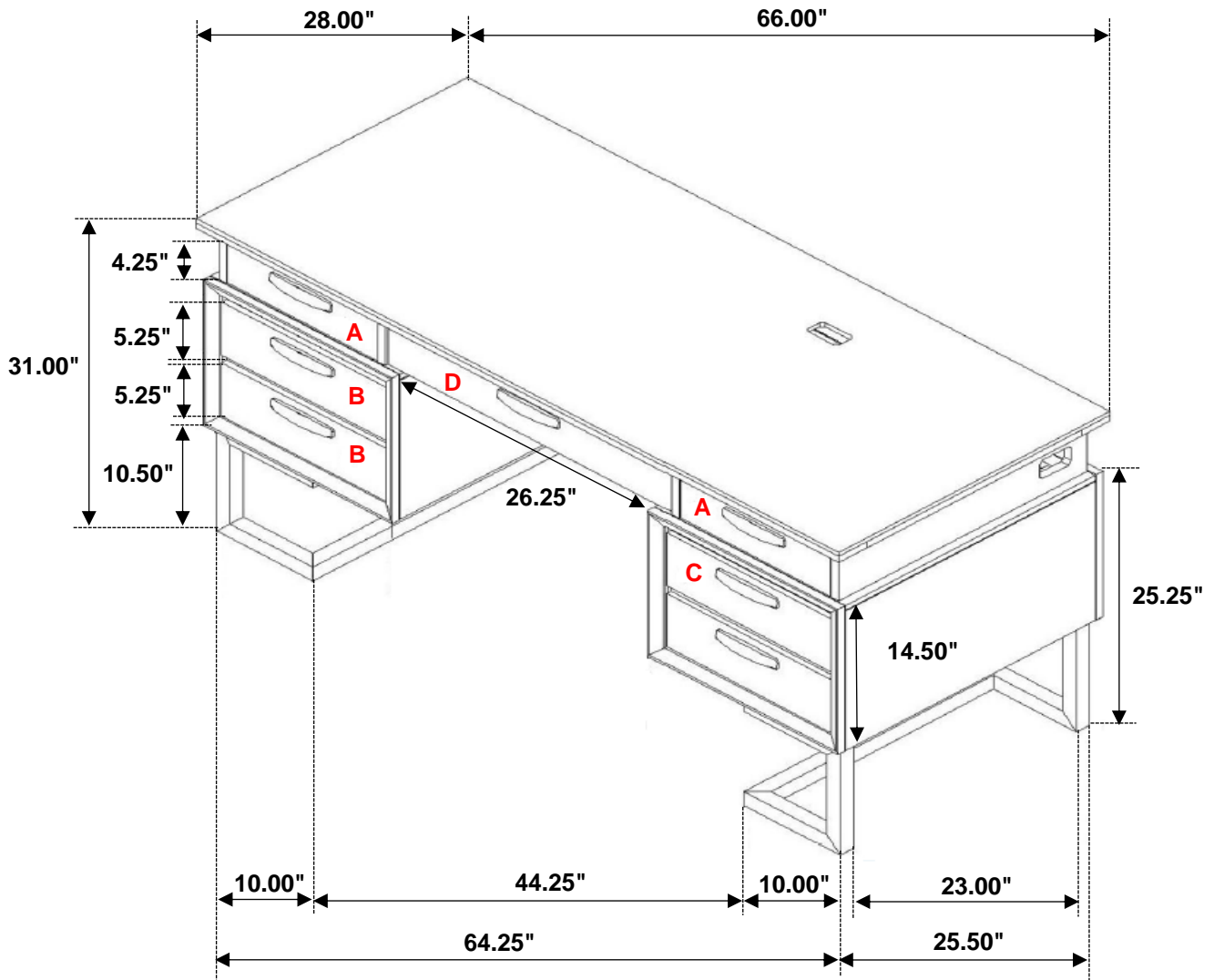

Note: Dimension tolerance $\pm 5\%$