



*ASSEMBLY INSTRUCTIONS  
COASTER FINE FURNITURE*



*Fine Furniture for every stage of life*

**105278**  
***Counter Height Table***

REVISION 0: 12/17/2013  
REVISION 1: 12/05/2019

**PAGE 1 OF 4**

COASTERFURNITURE.COM

# ITEM: 105278



## ASSEMBLY INSTRUCTIONS

### ASSEMBLY TIPS:

1. Remove hardware from box and sort by size.
2. Please check to see that all hardware and parts are present prior to start of assembly.
3. Please follow attached instructions in the same sequence as numbered to assure fast & easy assembly.



### WARNING!

1. Don't attempt to repair or modify parts that are broken or defective. Please contact the store immediately.
2. This product is for home use only and not intended for commercial establishments.



ASSEMBLY TIME

15 MINUTES

## PARTS IDENTIFICATION

A	SIDE PANEL WITH EXTRA CLEAT		1PC	E	LEAF		1PC
B	SIDE PANEL		2PCS	F	LEG		4PCS
C	DOOR PANEL		1PC	G	TOP PANEL		1PC
D	TOP		1PC	H	BOTTOM PANEL		1PC

## HARDWARE IDENTIFICATION

1	HEX NUT ( Ø5/16" x 1/2" - RBW )		4PCS	6	FLAT HEAD SCREW ( Ø3.5 x 1/2" - RBW )		4PCS
2	BOLT ( Ø1/4" x 1-3/16" - RBW )		14PCS	7	DOOR HINGE ( 120mm - RBW )		1PC
3	LOCK WASHER ( Ø5/16" - RBW )		18PCS	8	ALLEN WRENCH ( M4 x 59mm - RBW )		1PC
4	SMALL FLAT WASHER ( Ø1/4" x 16mm - RBW )		14PCS	9	WRENCH ( M4 x 50mm - RBW )		1PC
5	BIG FLAT WASHER ( Ø5/16" x 22mm - RBW )		4PCS				

### NOTE:

Phillips head screw driver is required in the assembly process; however, manufacturer does not provide this item.

ITEM: **105278**

**ASSEMBLY INSTRUCTIONS**

**STEP 1**

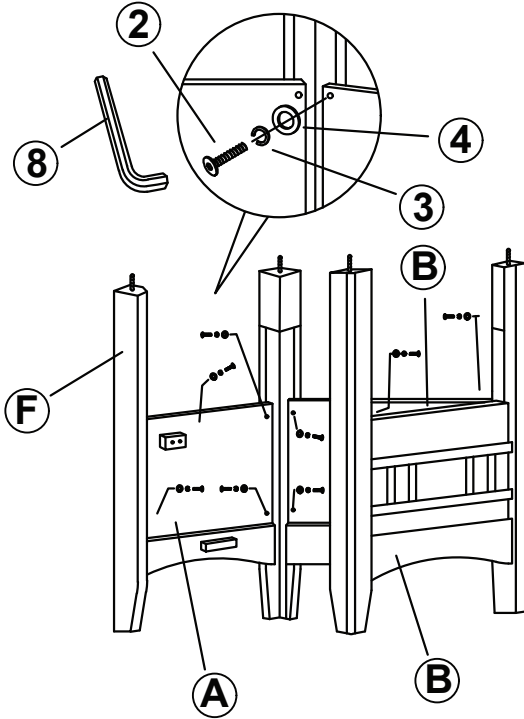

**STEP 2**

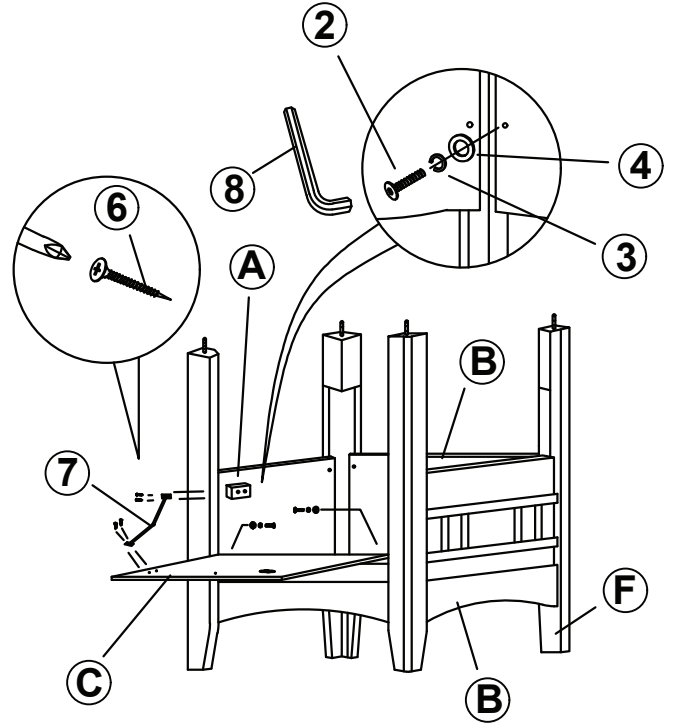

**STEP 3**

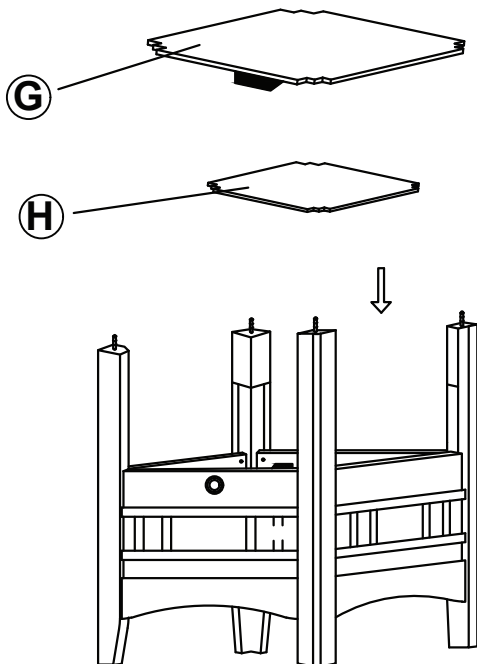

**STEP 4**

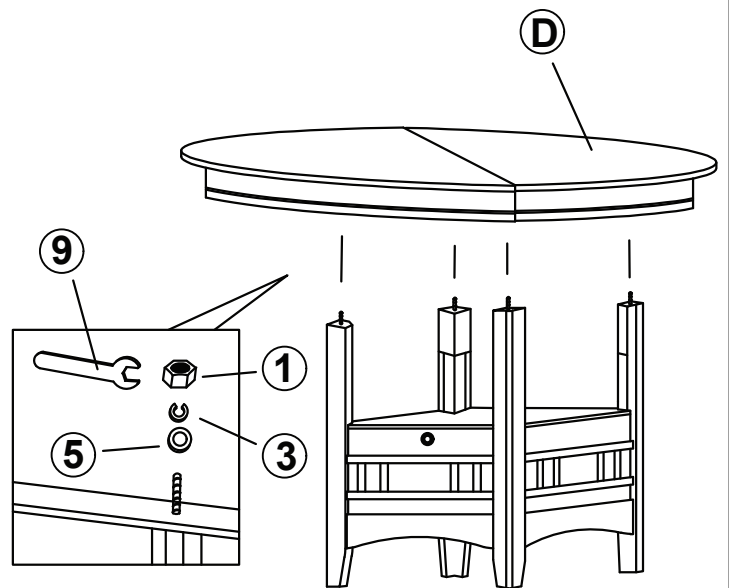

ITEM: **105278**

**ASSEMBLY INSTRUCTIONS**

**STEP 5**

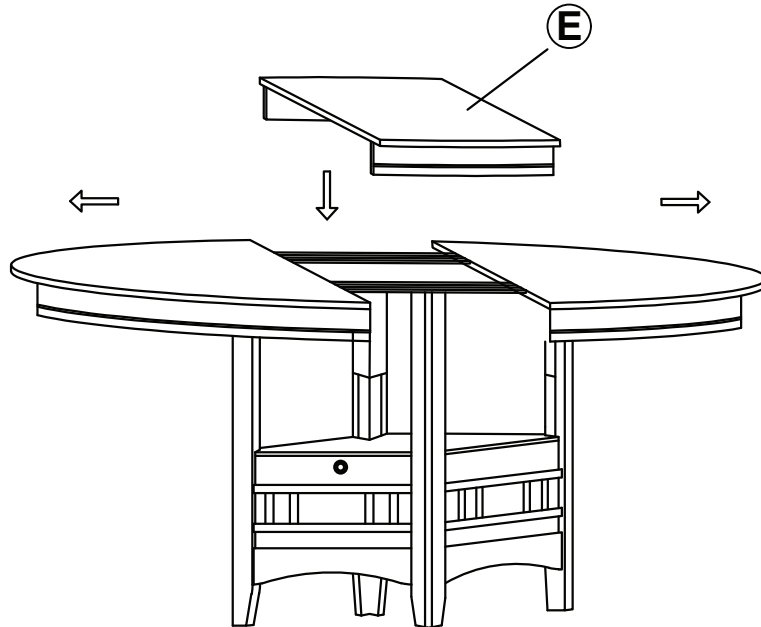

**STEP 6**  
**COMPLETE**

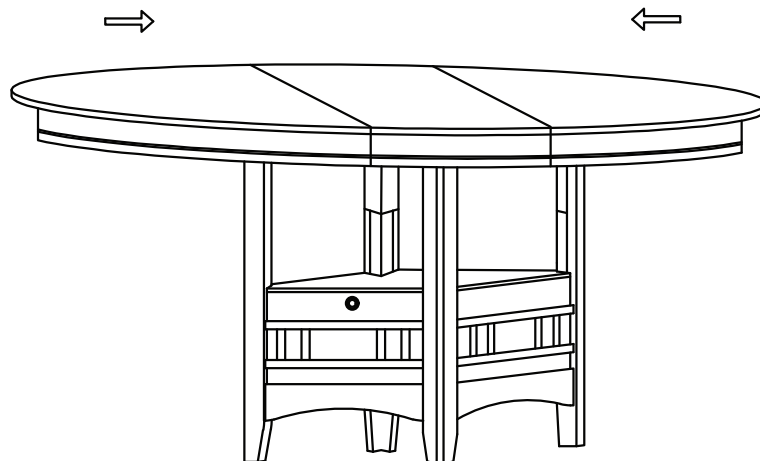

ITEM: **105278**



Inner Size of Compartment : 15.00"W x 15.00"D x 9.00"H

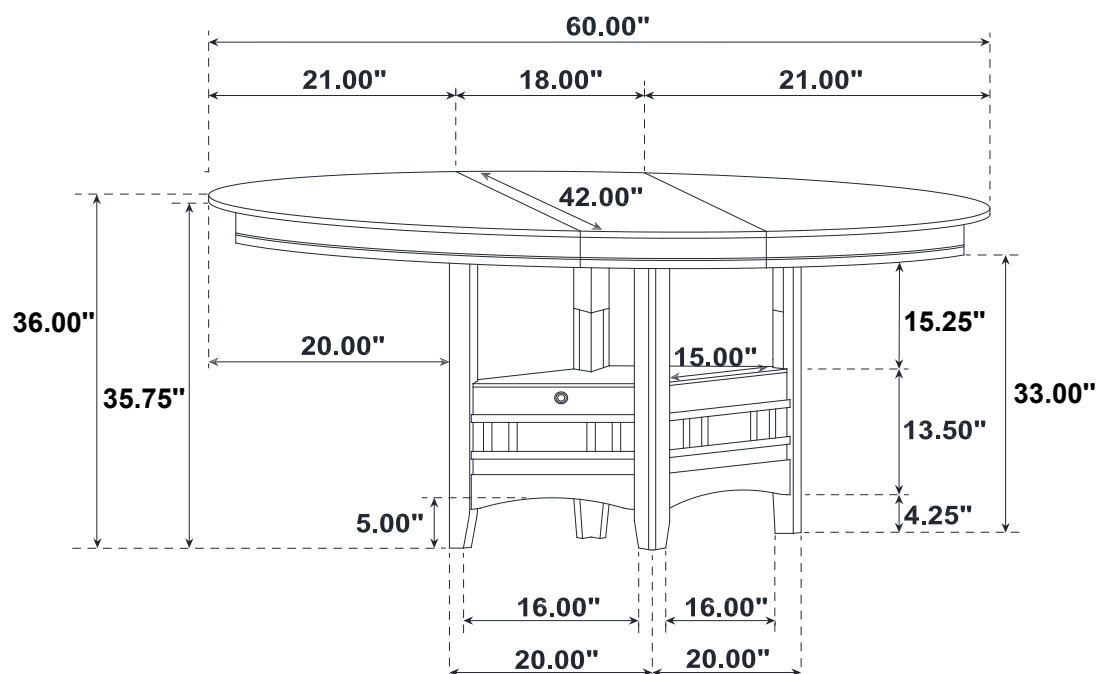

Note: Dimension tolerance  $\pm 5\%$