

ASSEMBLY INSTRUCTIONS
COASTER FINE FURNITURE



Fine Furniture for every stage of life

106383
Bench

ITEM: 106383



ASSEMBLY INSTRUCTIONS

ASSEMBLY TIPS :

1. Remove hardware from box and sort by size.
2. Please check to see that all hardware and parts are present prior to start of assembly.
3. Please follow attached instructions in the same sequence as numbered to assure fast & easy assembly.



WARNING !

1. Don't attempt to repair or modify parts that are broken or defective. Please contact the store immediately.
2. This product is for home use only and not intended for commercial establishments.

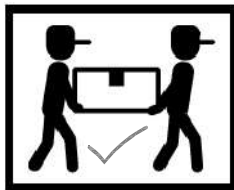

ASSEMBLY TIME

30 MINUTES

PARTS IDENTIFICATION

A SEAT

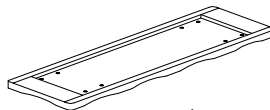

1PC

B LEG



2PCS

C TRESTLE BAR

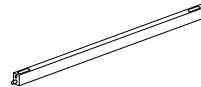

1PC

HARDWARE IDENTIFICATION

1 ALLEN WRENCH
(M4 x 110MM - BLK)



1PC

2 LONG BOLT
(M6 x 50MM - RBW)

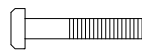

2PCS

3 MEDIUM BOLT
(M6 x 30MM - RBW)



8PCS

4 LOCK WASHER
(1/4" - BLK)



10PCS

5 FLAT WASHER
(M6 X 13MM - RBW)



10PCS

ITEM: **106383**
ASSEMBLY INSTRUCTIONS
STEP 1

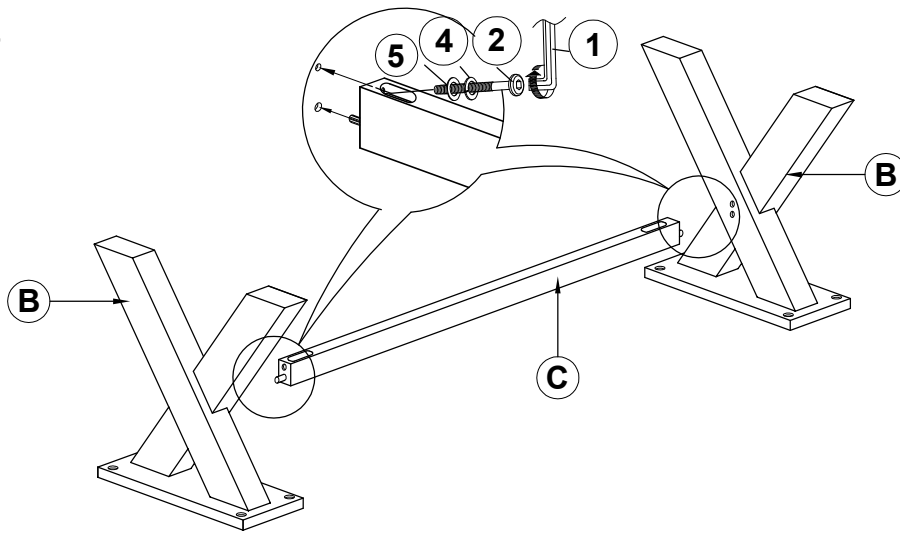

STEP 2

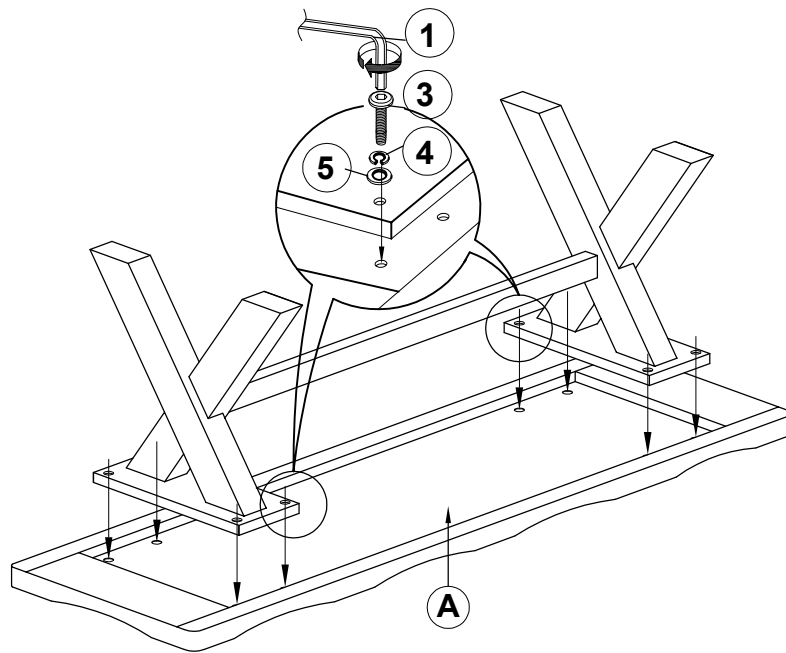

STEP 3
COMPLETE

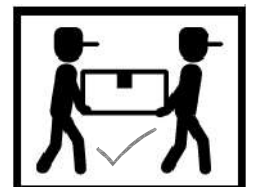
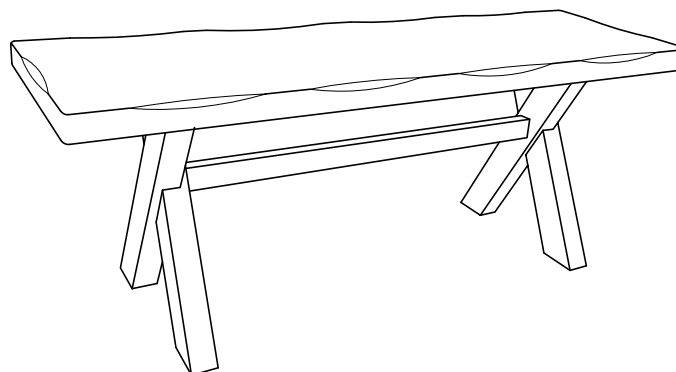

ITEM: **106383**

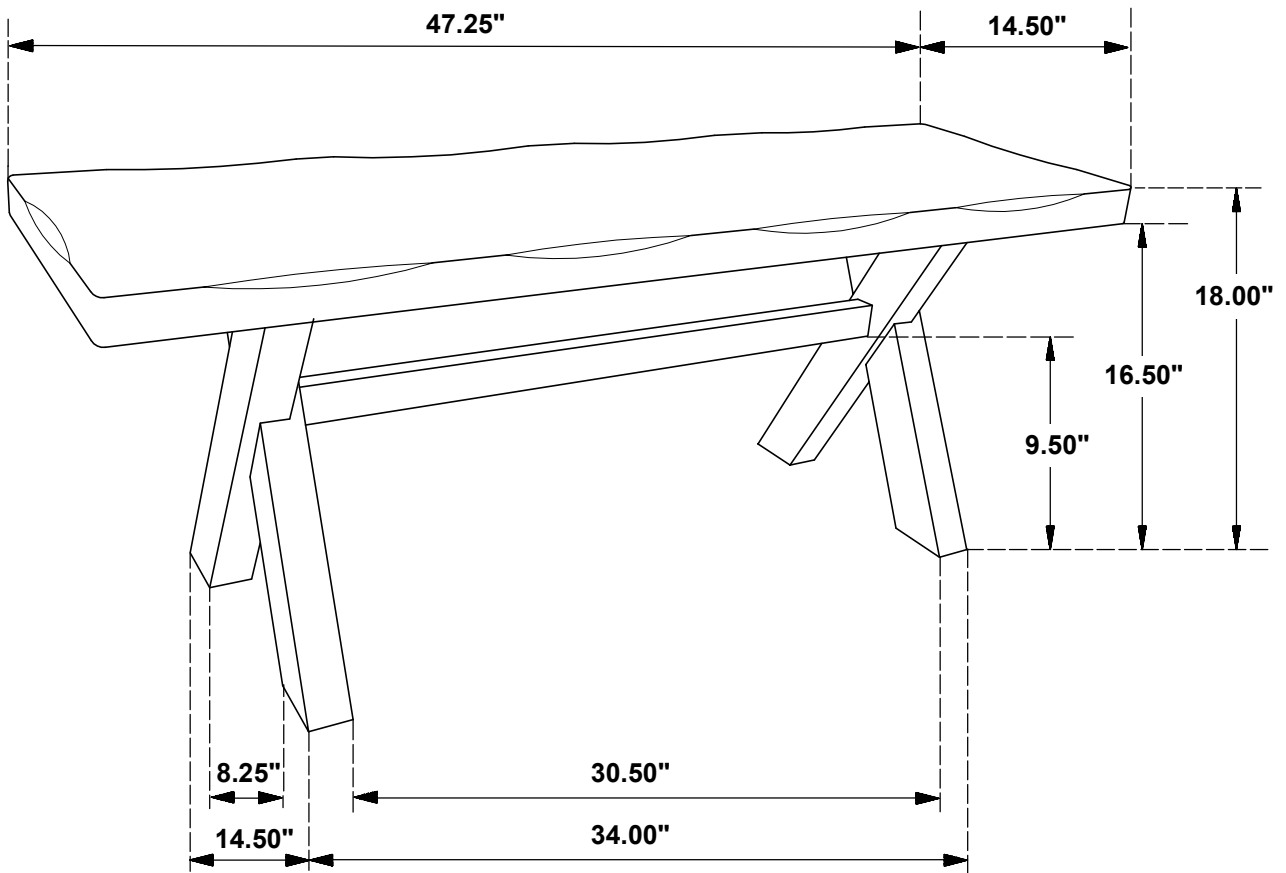

Note: Dimension tolerance $\pm 5\%$